

DC/DC Converter

VRA(B)_LD-15WR2 & VRA(B)_LD-20WR2 Series

15W&20W, wide input isolated & regulated dual / single output DC/DC converter



Patent Protection **RoHS** **CE**

VRA(B)_LD-15WR2 & VRA(B)_LD-20WR2 series are applied to wide voltage range input situation such as data transmission device, battery power supply device, telecommunication device, distributed power supply system, remote control system, industrial robot system etc.

FEATURES

- | Wide range of input voltage (2:1)
- | Efficiency up to 90%
- | Isolation voltage : 1.5K VDC
- | Output over-voltage, over-current and short circuit protection
- | Operating temperature range: -40°C to +85°C
- | Six-sided metal shielding package
- | International standard pin-out
- | Meet CISPR22/EN55022 CLASS A
- | A2S (wring mounting) and A4S (35mm rail mounting) products featuring anti-reverse connection for input
- | Meet EN60950

Selection Guide

Certification	Part No. ①	Input Voltage (VDC)		Output		Efficiency ③ (% Typ.) @ Full Load	Max. Capacitive Load ④ (μF)
		Nominal (Range)	Max. ②	Output Voltage (VDC)	Output Current (mA) (Max./Min.)		
CE	VRA1205LD-15WR2	12 (9-18)	20	±5	±1500/±75	86	1020
	VRA1212LD-15WR2			±12	±625/±32	88	495
	VRA1215LD-15WR2			±15	±500/±25	88	165
	VRA1224LD-15WR2			±24	±313/±16	88	200
	VRB1203LD-15WR2			3.3	4000/200	87	10500
	VRB1205LD-15WR2			5	3000/150	89	4020
	VRB1212LD-15WR2			12	1250/63	89	1035
	VRB1215LD-15WR2			15	1000/50	89	705
	VRB1224LD-15WR2			24	625/32	90	250
	VRA2405LD-15WR2			24 (18-36)	40	±5	±1500/±75
	VRA2412LD-15WR2	±12	±625/±32			88	495
	VRA2415LD-15WR2	±15	±500/±25			88	165
	VRA2424LD-15WR2	±24	±313/±16			88	200
	VRB2403LD-15WR2	3.3	4000/200			88	10500
	VRB2405LD-15WR2	5	3000/150			90	4020
	VRB2412LD-15WR2	12	1250/63			89	1035
	VRB2415LD-15WR2	15	1000/50			90	705
	VRB2424LD-15WR2	24	625/32			90	250
	VRA4805LD-15WR2	48 (36-75)	80			±5	±1500/±75
	VRA4812LD-15WR2			±12	±625/±32	88	495
	VRA4815LD-15WR2			±15	±500/±25	88	165
	VRA4824LD-15WR2			±24	±313/±16	88	200
	VRB4803LD-15WR2			3.3	4000/200	87	10500
	VRB4805LD-15WR2			5	3000/150	87	4020
	VRB4812LD-15WR2			12	1250/63	89	1035

Selection Guide

Certification	Part No. ①	Input Voltage (VDC)		Output		Efficiency ③ (% Typ.) @ Full Load	Max. Capacitive Load ④ (µF)		
		Nominal (Range)	Max. ②	Output Voltage (VDC)	Output Current (mA)(Max./Min.)				
CE	VRB4815LD-15WR2	48 (36-75)	80	15	1000/50	90	705		
	VRB4824LD-15WR2			24	625/32	89	250		
	VRA1205LD-20WR2	12 (9-18)	20	±5	±2000/±100	86	4800		
	VRA1212LD-20WR2			±12	±834/±42	88	800		
	VRA1215LD-20WR2			±15	±667/±34	88	500		
	VRA1224LD-20WR2			±24	±417/±21	88	300		
	VRB1203LD-20WR2			3.3	5000/250	86	18700		
	VRB1205LD-20WR2			5	4000/200	89	9600		
	VRB1212LD-20WR2			12	1667/84	89	1600		
	VRB1215LD-20WR2			15	1333/67	89	1000		
	VRB1224LD-20WR2			24	834/42	90	470		
	VRA2405LD-20WR2			24 (18-36)	40	±5	±2000/±100	86	4800
	VRA2412LD-20WR2					±12	±834/±42	88	800
	VRA2415LD-20WR2					±15	±667/±34	88	500
	VRA2424LD-20WR2	±24	±417/±21			88	300		
	VRB2403LD-20WR2	3.3	5000/250			86	18700		
	VRB2405LD-20WR2	5	4000/200			90	9600		
	VRB2412LD-20WR2	12	1667/84			89	1600		
	VRB2415LD-20WR2	15	1333/67			90	1000		
	VRB2424LD-20WR2	24	834/42			90	470		
	VRA4805LD-20WR2	48 (36-75)	80			±5	±2000/±100	86	4800
	VRA4812LD-20WR2					±12	±834/±42	88	800
	VRA4815LD-20WR2					±15	±667/±34	89	500
	VRA4824LD-20WR2			±24	±417/±21	89	300		
	VRB4803LD-20WR2			3.3	5000/250	86	18700		
	VRB4805LD-20WR2			5	4000/200	90	9600		
	VRB4812LD-20WR2			12	1667/84	89	1600		
	VRB4815LD-20WR2			15	1333/67	90	1000		
	VRB4824LD-20WR2			24	834/42	89	470		

Note:
 ① Series with suffix "H" are heat sink mounting; series with suffix "A2S" are chassis mounting, with suffix "A4S" are DIN-Rail mounting, for example VRB2405LD-20WHR2A2S is chassis mounting of with heat sink, VRB2405LD-20WR2A4S is DIN-Rail mounting of without heat sink; if the application has a higher requirement for heat dissipation, you can choose modules with heat sink;
 ② Absolute maximum rating without damage on the converter, but it isn't recommended;
 ③ The efficiency of A2S (wiring type) and A4S (rail type) products is 2% lower than the above-mentioned value due to the reverse connection protection for input;
 ④ The capacitive loads of positive and negative outputs are identical.

Input Specifications

Item	Operating Conditions			Min.	Typ.	Max.	Unit
Input Current (full load / no-load)	15W	12VDC input	3.3VDC/5VDC output	--	1405/60	--	mA
			others	--	1405/25	--	
		24VDC input	3.3VDC/5VDC output	--	695/35	--	
			others	--	695/20	--	
		48VDC input	3.3VDC/5VDC output	--	360/35	--	
			others	--	355/15	--	

Input Current (full load / no-load)	20W	12VDC input	3.3VDC/5VDC output	--	1872/60	--			
			others	--	1872/25	--			
		24VDC input	3.3VDC/5VDC output	--	926/40	--			
			others	--	948/20	--			
		48VDC input	3.3VDC/5VDC output	--	463/25	--			
			others	--	469/10	--			
Reflected Ripple Current	12VDC input		--	30	--				
	24VDC input		--	30	--				
	48VDC input		--	30	--				
Input impulse Voltage (1sec. max.)	12VDC input		-0.7	--	25	VDC			
	24VDC input		-0.7	--	50				
	48VDC input		-0.7	--	100				
Input Filter	Pi filter								
Starting Time	Nominal input & constant resistance load		--	10	--	ms			
Ctrl*	Module switch on		Ctrl suspended or connected to TTL high level (2.5-12VDC)						
	Module switch off		Ctrl pin connected to GND or low level (0-1.2VDC)						
	Input current when switched off		--	1	--	mA			

Note: * the voltage of Ctrl pin is relative to input pin GND.

Output Specifications

Item	Operating Conditions	Min.	Typ.	Max.	Unit	
Positive Voltage Accuracy		--	±1	±3	%	
Negative Voltage Accuracy						
Balance of Output Voltage	Dual output, balanced load	--	±0.5	±1		
Line Regulation	Full load, the input voltage is from low voltage to high voltage	--	±0.2	±0.5		
Load Regulation	5%-100% load	--	±0.5	±1		
Cross Regulation	Dual output, main circuit with 50% load, auxiliary circuit with 10%-100% load	--	--	±5		
Transient Recovery Time	25% load step change	--	300	500	μs	
Transient Response Deviation		--	±3	±5	%	
Temperature Drift Coefficient	Full load	--	±0.02	--	%/°C	
Ripple & Noise *	20MHz bandwidth	--	70	100	mV p-p	
Trim		--	±10%Vo	--	VDC	
Output Over-voltage Protection	3.3VDC output		--	3.9		--
	5VDC output		--	6.2		--
	12VDC output		--	15		--
	15VDC output		--	18		--
	24VDC output		--	30	--	
Output Over-current Protection	Input voltage range	--	150	--	%	
Output Short circuit Protection		Hiccup, Continuous, self-recovery				

Note: * Ripple and noise tested with "parallel cable" method, please see *DC-DC Converter Application Notes* for specific operation methods.

General Specifications

Item	Operating Conditions	Min.	Typ.	Max.	Unit	
Isolation Voltage	Input-output, with the test time of 1 minute and the leak current lower than 1mA	1500	--	--	VDC	
Isolation Resistance	Input-output, isolation voltage 500VDC	1000	--	--	MΩ	
Isolation Capacitance	Input-output, 100KHz/0.1V	15W	24VDC output	--	2000	pF
			others	--	1000	
		20W	--	1000	--	

Operating Temperature	see Fig. 1	-40	--	85	℃
Storage Temperature		-55	--	125	
Storage Humidity	Non-condensing	5	--	95	%RH
Max. Operating Temperature for casing	Within the operating temperature curve	--	--	105	℃
Pin Welding Resistance Temperature	Welding spot is 1.5mm away from the casing, 10 seconds	--	--	300	
Vibration		10-55Hz, 10G, 30 Min. along X, Y and Z			
Switching Frequency	PWM mode	--	300	--	KHz
MTBF	MIL-HDBK-217F@25℃	1000	--	--	K hours

Physical Specifications

Casing Material	Aluminum alloy				
Package Dimensions	Without heat sink	Horizontal package	50.80*25.40*11.80mm		
		A2S wiring package	76.00*31.50*21.20 mm		
		A4S rail package	76.00*31.50*25.80 mm		
	With heat sink	Horizontal package	50.80*25.40*16.30mm		
		A2S wiring package	76.00*31.50*25.10 mm		
		A4S rail package	76.00*31.50*29.70 mm		
Weight	Without heat sink	Horizontal package/A2S wiring package/A4S rail package	28.00g/50.00g/70.00g(Typ.)		
	With heat sink	Horizontal package/A2S wiring package/A4S rail package	36.00g/58.00g/78.00g(Typ.)		
Cooling Method	Free air convection				

EMC Specifications

EMI	Conducted disturbance	CISPR22/EN55022 CLASS A (Bare component)/ CLASS B (see Fig.3-② for recommended circuit)		
	Radiated emission	CISPR22/EN55022 CLASS A (Bare component)/ CLASS B (see Fig.3-② for recommended circuit)		
EMS	Electrostatic discharge	IEC/EN61000-4-2	Contact ±4KV	perf. Criteria B
	Radiation immunity	IEC/EN61000-4-3	10V/m	perf. Criteria A
	EFT	IEC/EN61000-4-4	±2KV (see Fig.3-① for recommended circuit)	perf. Criteria B
	Surge immunity	IEC/EN61000-4-5	±2KV (see Fig.3-① for recommended circuit)	perf. Criteria B
	Conducted disturbance immunity	IEC/EN61000-4-6	3 Vr.m.s	perf. Criteria A
	Immunities of voltage dip, drop and short interruption	IEC/EN61000-4-29	0-70%	perf. Criteria B

Product Characteristic Curve

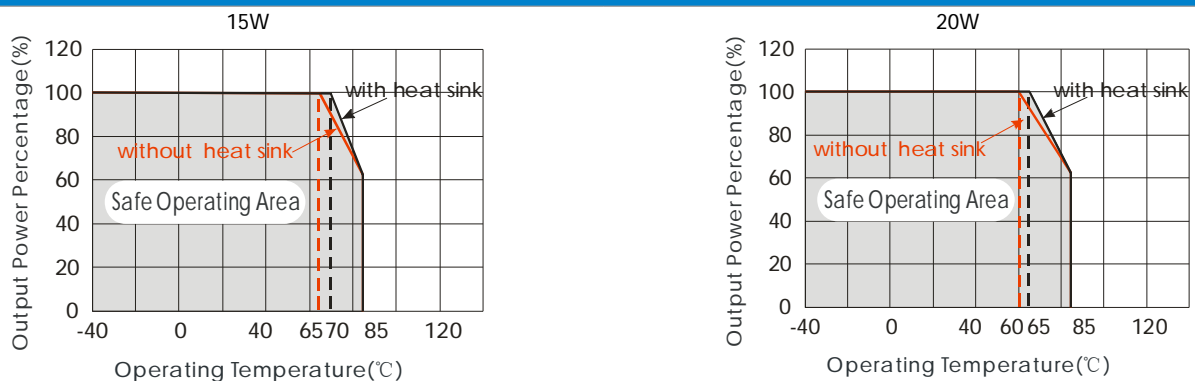
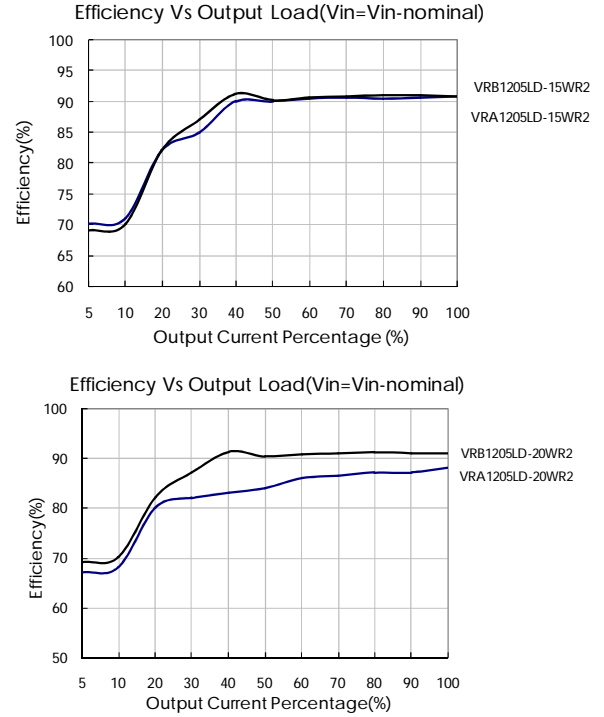
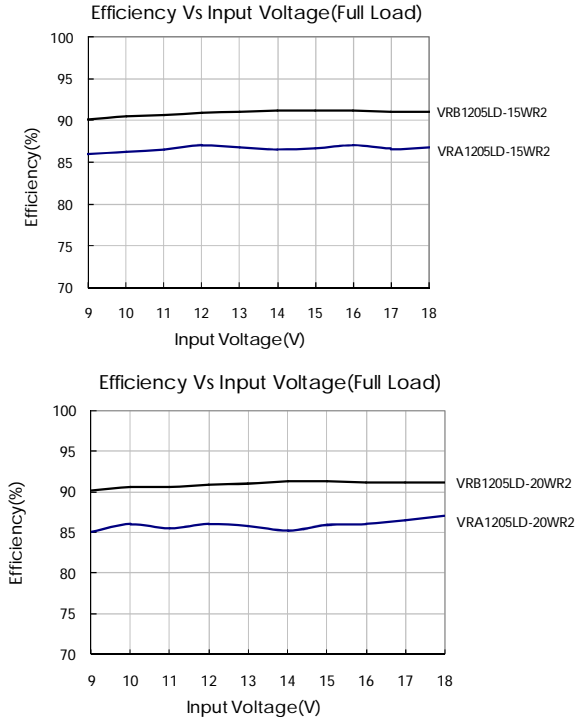

Fig. 1



Design Reference

1. Typical application

All the DC/DC converters of this series are tested according to the recommended circuit (see Fig. 2) before delivery. If it is required to further reduce input and output ripple, properly increase the input & output of additional capacitors C_{in} and C_{out} or select capacitors of low equivalent impedance provided that the capacitance is no larger than the max. capacitive load of the product.

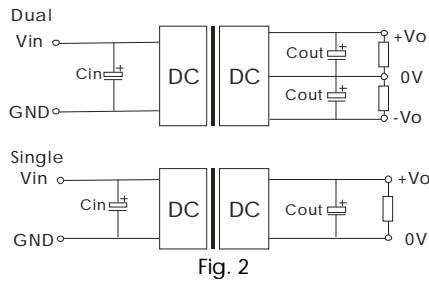

	Vout(VDC)	Cin(μ F)	Cout(μ F)
Dual	± 5	100	220
	$\pm 12/\pm 15$		100
	± 24		47
Single	3.3/5	100	470
	12/15		220
	24		100

2. EMC solution-recommended circuit

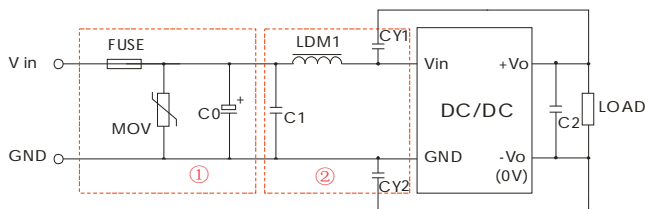

Notes: Part ① in the Fig. 3 is used for EMS test and part ② for EMI filtering; selected based on needs.

Parameter description

型号	Vin:12V	Vin:24V	Vin:48V
FUSE	Choose according to actual input current		
MOV	--	S14K35	S14K60
C0	680 μ F/25V	330 μ F/50V	330 μ F/100V
C1	1 μ F/50V	1 μ F/50V	1 μ F/100V
C2	Refer to the Cout in Fig.2		
LDM1	4.7 μ H		
CY1、CY2	1nF/2KV		

EMC solution-recommended circuit PCB layout

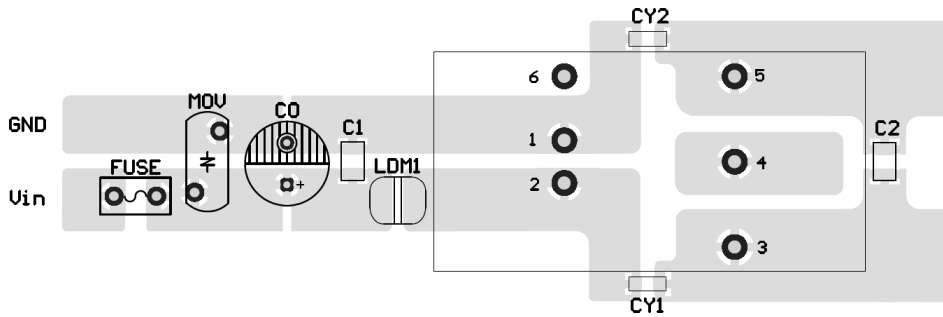
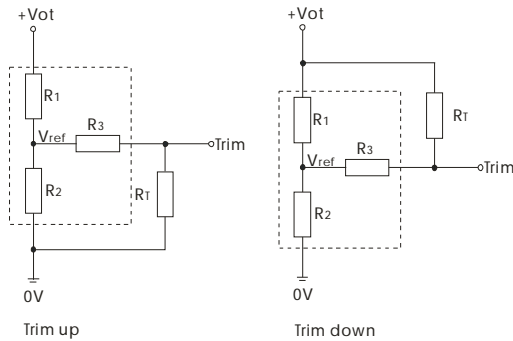

Fig. 4

Note: the min. distance of the bonding pads between input & output isolation capacitors (CY1/CY2) shall be ≥ 2mm.

1. Application of Trim and calculation of Trim resistance



Calculation formula of Trim resistance:

$$\text{up: } R_T = \frac{aR_2}{R_2 - a} - R_3 \quad a = \frac{V_{ref}}{V_o' - V_{ref}} \cdot R_1$$

$$\text{down: } R_T = \frac{aR_1}{R_1 - a} - R_3 \quad a = \frac{V_o' - V_{ref}}{V_{ref}} \cdot R_2$$

Applied circuits of Trim (Part in broken line is the interior of models)

Note: Leave open if not used. R_T : Resistance of Trim. a : User-defined parameter, no actual meanings.

Vout(V)	R1(KΩ)	R2(KΩ)	R3(KΩ)	Vref(V)
3.3	4.801	2.863	15	1.24
5	2.883	2.864	10	2.5
12	10.971	2.864	17.8	2.5
15	14.497	2.864	17.8	2.5
24	24.872	2.863	20	2.5

3. The product does not support output in parallel with power per liter or hot-plug use

4. For more information please find the application notes on www.mornsun-power.com

Dimensions and Recommended Layout(without heatsink)

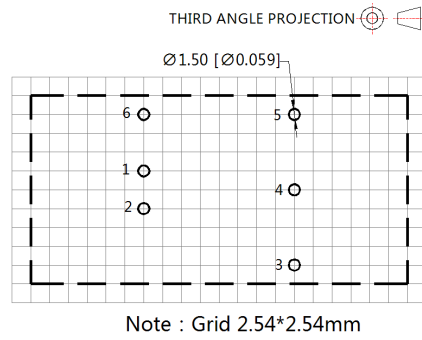
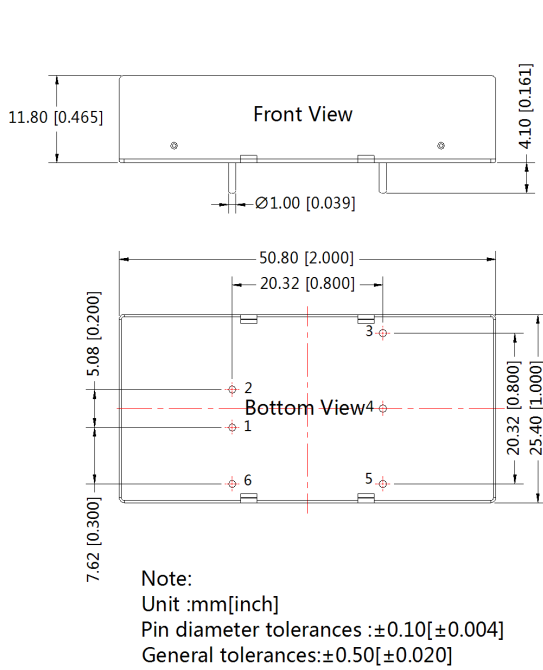

Pin-Out		
Pin	Single	Dual
1	GND	GND
2	Vin	Vin
3	+Vo	+Vo
4	Trim	0V
5	0V	-Vo
6	Ctrl	Ctrl

Dimensions (with heatsink)

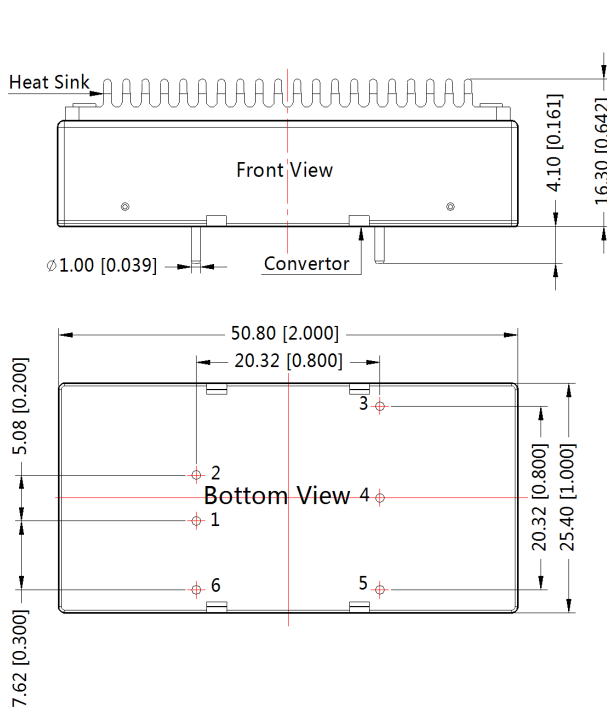

THIRD ANGLE PROJECTION

Pin-Out		
Pin	Single	Dual
1	GND	GND
2	Vin	Vin
3	+Vo	+Vo
4	Trim	0V
5	0V	-Vo
6	Ctrl	Ctrl

Note:
 Unit :mm[inch]
 General tolerances:±0.50[±0.020]
 If use heatsinks,make sure there is enough space for a special size in ther above graph

A2S Wiring Package Dimensions(without heatsink)

THIRD ANGLE PROJECTION 

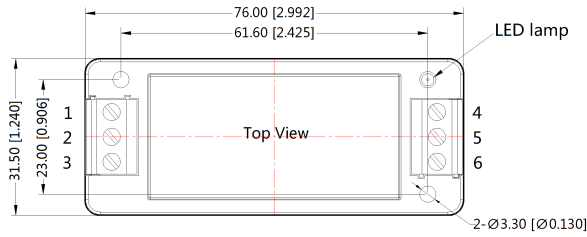

Pin-Out						
Pin	1	2	3	4	5	6
Dual	Ctrl	GND	Vin	-Vo	0V	+Vo
Single	Ctrl	GND	Vin	0V	Trim	+Vo

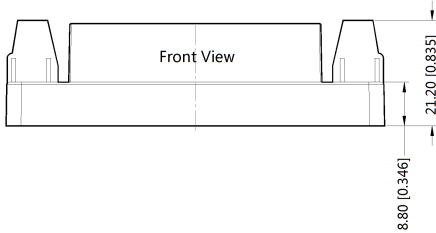

Note:
Unit:mm[inch]
Wire range : 24~12 AWG
General tolerances:±0.50[±0.020]

A2S Wiring Package Dimensions(with heatsink)

THIRD ANGLE PROJECTION 

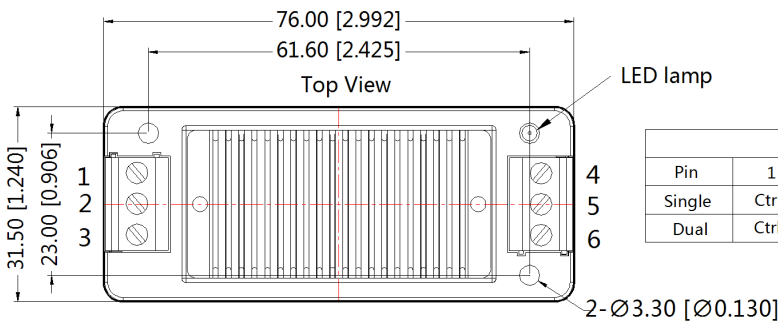

Pin-Out						
Pin	1	2	3	4	5	6
Single	Ctrl	GND	Vin	0V	Trim	+Vo
Dual	Ctrl	GND	Vin	-Vo	0V	+Vo

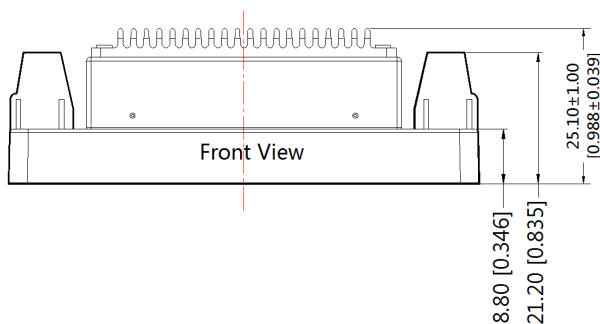

Note:
Unit:mm[inch]
Wire range:24~12 AWG
General tolerances:±0.50[±0.020]

A4S Rail Package Dimensions(without heatsink)

THIRD ANGLE PROJECTION 

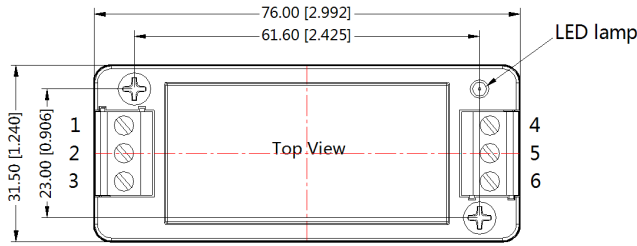

Pin-Out						
Pin	1	2	3	4	5	6
Dual	Ctrl	GND	Vin	-Vo	0V	+Vo
Single	Ctrl	GND	Vin	0V	Trim	+Vo

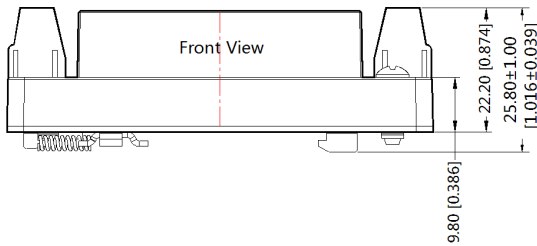

Note:
Unit:mm[inch]
Wire range : 24~12 AWG
General tolerances:±0.50[±0.020]

A4S Rail Package Dimensions(with heatsink)

THIRD ANGLE PROJECTION 

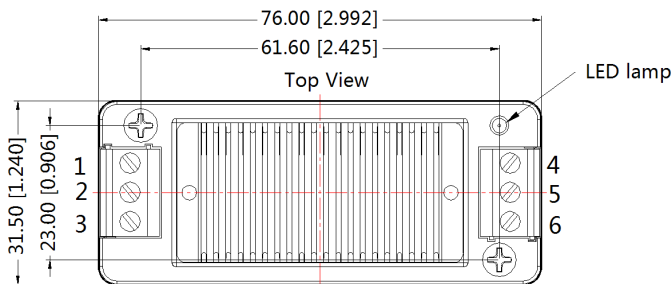

Pin-Out						
Pin	1	2	3	4	5	6
Single	Ctrl	GND	Vin	0V	Trim	+Vo
Dual	Ctrl	GND	Vin	-Vo	0V	+Vo

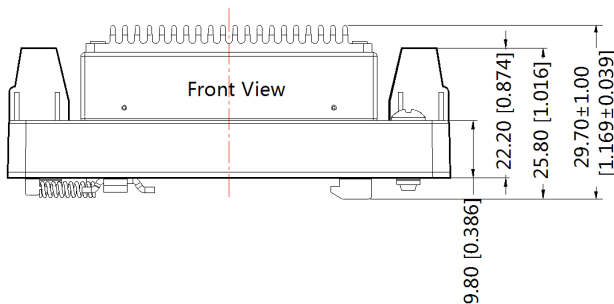

Note:
Unit:mm[inch]
Wire range:24~12 AWG
General tolerances:±0.50[±0.020]

Notes:

1. Packing Information please refer to 'Product Packing Information'. The Packing bag number of Horizontal package: 58200035(without heatsink),58200051(with heatsink), the Packing bag number of A2S/ A4S package: 58220022;
2. Recommended used in more than 5% load, if the load is lower than 5%, then the ripple index of the product may exceed the specification, but does not affect the reliability of the product;
3. The unbalance degree of the recommended dual output module load: $\leq 5\%$; if the degree exceeds $\pm 5\%$, then the product performances cannot be guaranteed to comply with all the performance indicators in the manual, and please directly contact our technicians for specific information;
4. The max. capacitive load should be tested within the input voltage range and under full load conditions;
5. Unless otherwise specified, data in this datasheet should be tested under the conditions of $T_a=25^\circ\text{C}$, humidity $<75\%$ when inputting nominal voltage and outputting rated load;
6. All index testing methods in this datasheet are based on our Company's corporate standards;
7. The performance indexes of the product models listed in this datasheet are as above, but some indexes of non-standard model products will exceed the above-mentioned requirements, and please directly contact our technicians for specific information;
8. We can provide product customization service;
9. Specifications of this product are subject to changes without prior notice.

Mornsun Guangzhou Science & Technology Co., Ltd.

Address: No. 5, Kehui St. 1, Kehui Development Center, Science Ave., Guangzhou Science City, Luogang District, Guangzhou, P. R. China
Tel: 86-20-38601850-8801 Fax: 86-20-38601272 E-mail: info@mornsun.cn