

DIM	TOL
5mm DOWN	±0.2
5~20mm	±0.3
20~40mm	±0.4
40~60mm	±0.5
60~100mm	±0.8
100mm UP	±1.0

REVISIONS			
REV	DESCRIPTION	DATE	BY

PART NO.	A	B
SG58400	6.0	4.0
SG58401	8.0	6.0
SG58402	10.0	6.0
SG58403	12.0	6.0
SG58404	15.0	6.0

PART NO.	A	B
SG58406	20.0	8.0
SG58408	25.0	6.0
SG58409	30.0	8.0

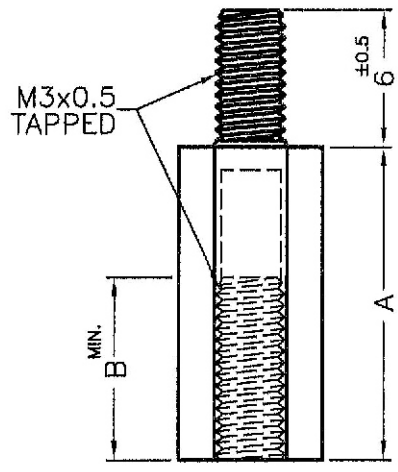
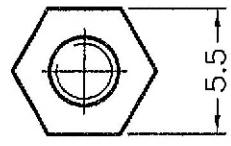

NOTE:(1)Inner thread was done by 2nd process tapping.
 Some slight nylon burrs remained inslide the thread hole is a normal phenomenon.
 (2)All measurement does not include gate which raises under 0.3mm.

PART NUMBER SEE ABOVE				TITLE THREADED SPACER		SPEC. DWG.	
				MATERIAL NYLON 66 UL94V-2		DATE 2004.01.07	
				FINISH		DRAWN JASON	
				COLOR NATURAL		CHECK 	
DRAWING NUMBER SG5840x		UNLESS OTHERWISE SPECIFIED TOLERANCE SEE ABOVE		APPROVED 			
SIZE A4	SCALE NONE	UNIT mm	REV K				