

产 品 规 格 书

PRODUCT SPECIFICATION

Customer Name 客户名称	
Customer Model 客户型号	
Application Project 适用项目	
Product Name 产品名称	Core DC Motor 铁芯直流电机
Product Model 产品型号	KHQ-RC-365SM-16115-51 CCW
REV. 版 次	A/0
The product according to the ROHS requirement 产品符合 ROHS 要求	

Customer Approved 客户确认	Checking 核 对	Inspection 审 查	Approval 批 准
CRE-ST Approved 本司确认	Drawing 编 制	Checking 审 核	Approval 批 准
	李灵	黄凯丽	杨韦艳

地址：深圳市宝安区沙井街道万丰中路214号B栋3楼

Add: Shenzhen Baoan District Shajing street Wanfeng Middle Road214 B building 3/F

电话 / Tel :0755-29192817

传真 / Fax:0755-27655316

重要提示 IMPORTANCE NOTES:

1. If there is any argument on motor performance and/or life, judgment is to be made base on this specification only.
如对电机的性能和/或寿命有任何争议，仅基于此规格书作出判断。
2. Customer has the responsibility to ensure that the motor can satisfy the requirement of your application.
客户方有责任确认该电机能满足您的申请要求。
3. In the event that an official specification is not present by customer; this document will specify the agreed technical specification with a performance curve data and outline drawing.
如果贵公司未提供技术规格，该文件将详细叙述与贵公司商定的技术规格包括特性曲线数据和外形图。
4. Within the limitation to satisfy this specification, CRE-ST has the convenience to change the materials, sizes and shapes of components of the motor for the purpose of improving quality, and/or performance, and/or production efficiency.
在满足规格的条件下，我司可以改变零件材料、尺寸及形状来改善品质，和/或性能，和/或生产效率。
5. After the receipt of this specification, customer should send a signed copy to CRE-ST prior order confirmation. CRE-ST regard it as the receipt of this specification acknowledged if customer fails to return the confirmation to us within the described period.
收到此规格书后，贵司应于该规格书发出至正式订单之前将规格书副本签回以示贵司收到确认。如贵司未能在规定时间内签回副本，我司将认为贵司已收到并承认该规格书。

更改记录
Revised Record

Rev. 版次	Date 日期	Reason for change 更改原因	Designed 编制	Checked 审核	Approval 批准
A/0	2020. 07. 31	首次发行	李灵	黄凯丽	杨韦艳

1.0 电机结构形式 The motor construction-form

NO. 序号	Item 项目	Contents 内容
1.1	Motor construction 电机结构	Φ28.7mm diameter as the core of the DC motor 外径为Φ28.7mm 的铁芯直流电机
1.2	Number of magnet poles 磁极极数	2-poles (Built-in magnetic ring) 两极(磁环内置)
1.3	Rectifying method 换向方式	Precious metal brush reversing device 碳刷换向装置

2.0 准使用条件 Standard operating condition

NO. 序号	Item 项目	Specification 规格
2.1	Rated voltage 额定电压	Motor terminal voltage 12.0VDC 电机端子电压 12.0VDC
2.2	Rated load 额定负荷	Fan 风叶
2.3	Rotation direction 旋转方向	CCW (When viewed from output side with +ve voltage applied to +ve terminal) 顺时针方向旋转(从输出端看, 电压正极接端子正极)
2.4	Motor position 摆放位置	Any position is available 任意位置均可
2.5	Voltage range for use 工作电压范围	DC12.0V~36.0V
2.6	Operating conditions 使用环境	-15℃~+90℃ ordinary humidity常规湿度 15%~90%RH (no condensation of moisture/不凝露)
2.7	Storage conditions 贮存环境	-15℃~90℃ ordinary humidity常规湿度 15%~90%RH (no condensation of moisture/不凝露)

3.0 产品测试环境条件 Environmental Test Conditions

NO. 序号	Item 项目	Environmental condition 测试环境条件
3.1	Temperature 温度	25±2℃
3.2	Humidity 湿度	60±5% RH
3.3	Motor Position 电机体位	Shaft Horizontal 轴伸水平
3.4	Power Supply 电源	DC12.0V±0.5%

NOTE: All data shall be based on the measurement under the temperature 25±2℃ and humidity 60±5% RH, however the range of temperature 5~35℃ and humidity 45~85%RH if there is no doubt about the judgment.

注: 所有的数据在温度 25±2℃, 湿度 60±5% RH的条件下测定。在对判定不发生异议时, 也可在温度 5~35℃, 湿度 45~85%RH的环境下测试。

4.0 电气性能 Electrical characteristics

NO. 序号	Item 项目	Measuring condition 测试条件	Specification 规格
4.1	No-Load current 空载电流	At rated voltage and no load 额定电压及无负荷下测试	100 mA Max
4.2	No-Load speed 空载转速	At rated voltage and no load 额定电压及无负荷下测试	7800±10% rpm
4.3	Rated load 额定负荷	Fan 风叶	R 风叶
4.4	Rated current 额定电流	Rated voltage and rated load 额定电压及额定负荷	500mA Max
4.5	Rated speed 额定转速	Rated voltage and rated load 额定电压及额定负荷	6100±10% rpm
4.6	Stall torque 堵转力矩	Rated voltage by torsionmeter 额定电压, 扭力计	229.4 g.cm Min
4.7	Stall current 堵转电流	Rated voltage rotor position to be 2/3R 额定电压, 转子位置 2/3R处	1.94 A Max
4.8	Starting voltage 起动电压	No load 无负荷	3.0V Max
4.9	Insulation resistance 绝缘电阻	At DC 100V, measured between housing case and terminal. 在 100V 直流电压下, 电机端子与外壳间测量	≥10MΩ
4.10	Rotor resistance 端子电阻	Rotor position to be 2/3R 转子位置外于 2/3R处	8.2 Ω REF

5.0 机械特性 Mechanical Characteristic

5.1	Configuration 外观尺寸	Vernier caliper 游标卡尺	As specified in outline drawing 参考外形图
5.2	Shaft end play 轴向间隙	Vernier caliper or Dial indicator 游标卡尺或百分表	0.05-0.35 mm
5.3	Weight 重量	Plate balance 0.1g 架盘天平 精度 0.1g	75.0g (Approx) 75.0g (左右)
5.4	Vibration 振动	Hand fell 手感	按限度样品
5.5	Maximum Axial Load 最大轴向力	Direction of static load 轴向静推力	≅5Kg.f

深圳市国领微特电机有限公司

马达性能曲线图

Sample No: H101031-4 Customer H008 Date: 2020-7-31
 Model: RC-365SM-16115-51

———— Efficiency
 - - - - - Power output

NOTE: Performance (in an ambient temperature of 25-30°C)
 Motor tested rapidly to prevent

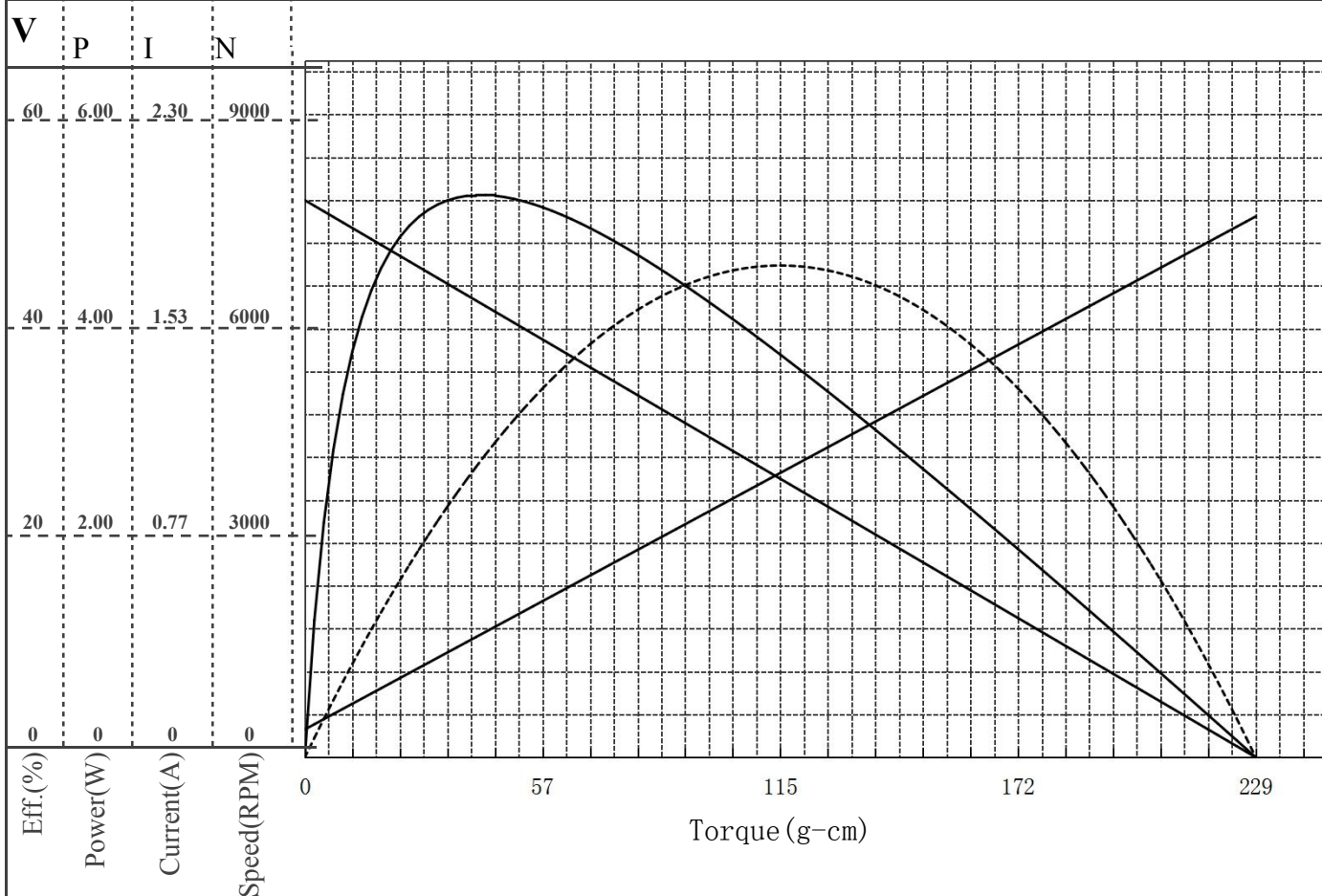

Constant voltage : **12.0** Volts
 Direction: **CCW**

At No Load
 Speed: **7800** rpm
 Current: **0.100** A

At stall(Extrapolated)
 Torque: **229.4** g-cm
 Current: **1.94** A

At maximum efficiency
 Efficiency: **52.5** %
 Torque: **50.0** g-cm
 Speed: **6100** rpm
 Current: **0.50** A
 Output: **3.13** W

At maximum Power output
 Output: **4.59** W
 Torque: **114.7** g-cm
 Speed: **3900** rpm
 Current: **1.02** A

Issued by QA Reliability Testing Center

COMPUTER PRINT-OUT

NOMINAL MOTOR CURVES

Performance and characteristics are measured based on limited motor samples only

Prepared by:

Checked by:

Approved by:

Date:

版次: A

MODEL/型号: KRC-365SM-16115-51 VOL TAGE: 12. V. DC

LOTNO/工程号: 2020.07.31

未注公差			圆角半径和倒角高度		
0~6	6~30	30~120	0~3	3~6	6~30
±0.06	±0.1	±0.2	±0.2	±0.5	±0.8

DIRECTION OF ROTATION

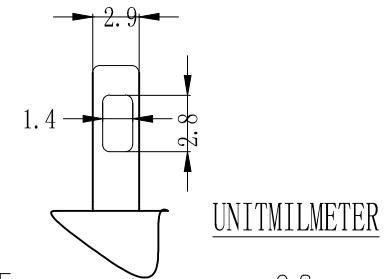
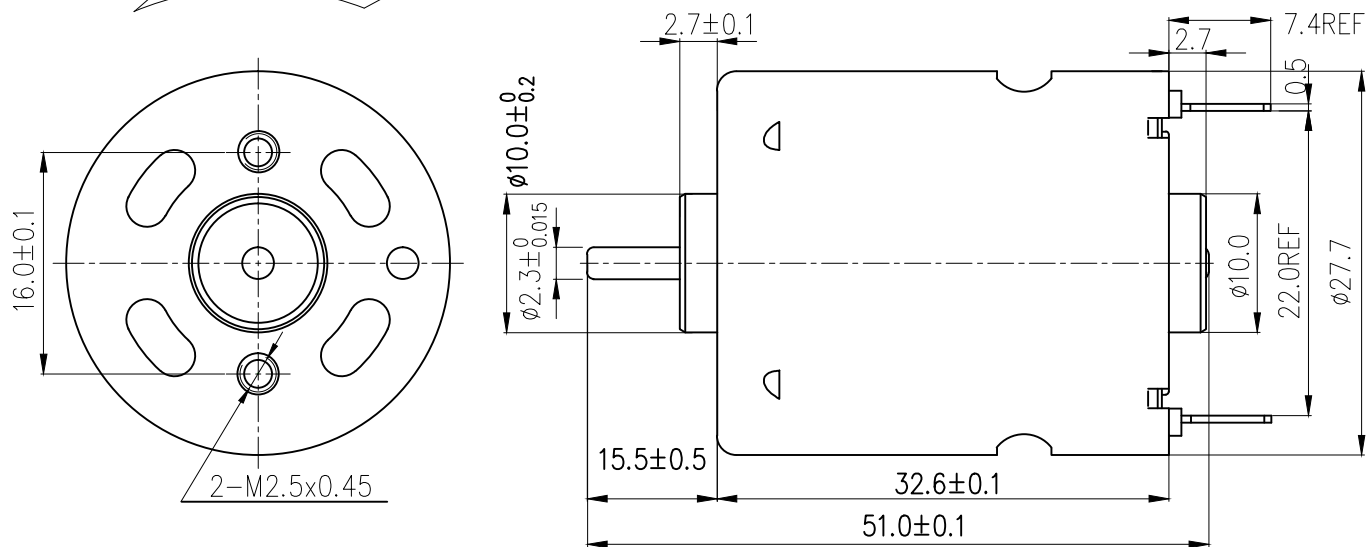

技术要求

1. 马达轴长尺寸为: 51.0mm ;
2. 马达前端轴伸长尺寸为: $15.5 \pm 0.5\text{mm}$ (轴枝向胶盖端推时测量);
3. 马达虚位尺寸为: 0.5mm MAX ;
4. 马达旋转方向: CCW (反转), 从马达的输出端看
5. 马达附加配件: 104 陶瓷电容, 环形压敏电阻
6. 马达重量大约: 49.1g
7. 螺纹孔相对于端子的位置有 15° 及 -15° ;
8. 螺钉拧入螺孔的最大深度为 2.5mm ;

共2页 第2页

TITEL: 外形图	A4	DRAWER:	
MUSTER NO: 365SM		CHECKER:	
深圳市国领微特电机有限公司		APPROVER:	
		DO NOT SCALE THE DAWING	
		DAWING NO.:	

电机使用说明

Instructions for use motor

1. 拒收 REJECTS

Motor that do not meet with the specifications mentioned above or which are apparently judged as faulty due to poor workmanship.

电机不能满足规格要求，或判定存在明显工艺缺陷。

2. 注意事项 CAUTIONS

1) 使用容差 ALLOWABLE RANGE FOR USE

Pay attention to voltage and current ranges for use ,and use the vibration motor in the condition accordance with this specifications ,or the life and performance should be considerably reduced.

注意电压及电流的使用范围，并且在本标准规定情况下使用电机，否则将相应降低电机的使用寿命和性能。

2) 移动电机 MOVE YOUR MOTOR

Please deal with the motors gently, you should make use of the outer case as possible as you can. 拿电机时，应轻拿轻放，应尽可能地利用外壳部分

Do not press the product with more than 5 kgf or drop it. It can cause the transformation of performance or external appearance.

请勿将其跌落或加以超过 5 公斤的压力。否则会引起电机的外部形态和电气特性的改变

3) 储存 STORAGE

Storage temperature: $-20^{\circ}\text{C}\sim 70^{\circ}\text{C}$

Storage relative humidity: 15%~75%

Avoids storing in high temperature、high humidity or corrosive gas environment.

储存温度： $-20^{\circ}\text{C}\sim 70^{\circ}\text{C}$

储存湿度：15%RH~90%RH

避免放置在高温、潮湿及有腐蚀性气体的环境中。

4) 使用电机 HANDLING OF MOTOR

-to handle and hold the vibration motor case softly.

-do not bring magnetized object near or contact with the surface of motor to avoid of performance being deteriorated.

-pay attention to the handling and working environments of motor, because such objects as iron powder if attracted by motor magnet, will cause noise characteristic deterioration, thus reducing the reliability.

小心拿取、使用。

避免放置在磁性物体附近或接触其表面，这将影响其功效。

注意操作环境，尤其注意若铁粉被磁铁吸附，将出现噪音问题，降低使用寿命

Please do not operate or store the motor near magnet or magnetic devices.

请勿靠近磁体或有磁场的装置存放或运行电机

5) 安装您的电机 MOUNTING YOUR MOTOR:

Some CRE-ST motors provide tapped holes in the motor housing for you to use to mount your motor. Please take care not to use screws so long that they can interfere with components inside the motor.

部分全新电机都在电机定子上提供了安装孔用来安装您的电机，请注意不要使用过长的螺钉以避免损坏电机内部元件。

Bearing bosses are also used for mounting motors. Please avoid excessive clamping forces on these areas.

轴承固定座也是用来安装您的电机的，对此安装区域请避免过度用力。

When mounting your motor, please try not to completely close or around the motor, motor should be set aside space for heat dissipation

在安装电机时，请尽量不要完全紧贴或包住电机，应为电机留出散热空间。

It is preferable not to use features on the motor such as ventilation holes for location means. It is possible that these features may change as new or modified tooling is used in the future.

最好不要利用电机表面的特征来固定电机，例如：通风孔。这样将可能会改变这些特征。

Any ventilation holes in the motor should not become blocked in your product without consultation with CRE-ST.

如未咨询我司，装入贵司产品中的电机上的任何通风孔都不可以堵死。

If adhesives are to be used to mount you motor care must be taken to avoid any adhesive getting into the bearing areas.

如果使用粘合剂安装电机，必须注意粘合剂不能进入轴承区域。

6) 电机接线 CONNECTION YOUR MOTOR:

Whatever means you are to use to connect your supply to your motor please take care not to use so much force or heat that you cause distortion to components inside the motor.

不论使用任何方式将您的电源连接到您的电机，请注意不能用过大的力或过高的温度，否则会造成电机内部零件变形。

7) 电机连轴 COUPLING YOUR MOTOR:

If you intend to couple a gear or a fan or some other item to your motor shaft during assembly, always remember that unusual radial and axial loads transmitted to the motor from the coupling during operation of the motor can have serious effects on the life of the bearings. If you have any concerns about this please consult with CRE-ST.

装配过程中，如果电机出轴端欲衔接齿轮、风叶等其它配件，请牢记，如果安装不当，电机运转时一种非正常的径向或轴向负荷将通过连接加载到电机，这种负荷将对轴承寿命造成严重影响。如果您对此有任何担心，请咨询我司。

8) 过负荷 OVERLOADS:

Small high power motors are subject to very fast temperature rises. Take care not to apply excessive voltage to the motor or to operate it at stall or near stall for prolonged periods without first consulting with CRE-ST.

体积小、功率高的电机通常温升高；如未咨询我司，使用时请注意不能加过高的电压，不能运行在堵转或接近堵转状态过长时间。

9) 危险环境 HAZARDOUS ENVIRONMENTS:

The degree of protection against corrosion on CRE-ST motors is satisfactory only for normal environments. There are small sections of the housing in which some bare metal is exposed and is susceptible to corrosion. It is advisable not to store or use motors in corrosive environment without consultation with CRE-ST.

我司电机在正常环境中的抗腐蚀能力是符合要求的，但机壳上有少许区域存在的裸露金属对腐蚀比较敏感，因此未经咨询请不要在腐蚀环境中储存或使用电机，

10) 其它说明 OTHERS:

The motor may cause slight electronic noise due to the contact between brush and commutator. 当换向器和电刷接触时，电机会发出轻微的电噪音

The motor has a strong magnet so please be aware that it has a magnetic force on the surface of the bracket.

电机内部有很强力的磁铁，所以机壳表面也存在磁力

It is allowable to have a few spots on the surface or edge of case.

外壳表面或边缘有少许斑点允许的

————— END —————