

JQX-13F-MY 小型大功率继电器
Power relay

型号说明 Part number description



JQX-13F-MY2C



JQX-13F-MY3C



JQX-13F-MY4C

JQX-13F-□□□□□

触点容量 Capacity of contact

MY:5A系列 Series

触点形式 Contact form

2,3,4(A:常开,B:常闭,C:转换)

(A:normally open,B:normally close,C:change)

安装与引出脚形式 Mount and terminal

无None:插入式 ordinary dust cover,plug-in terminal

P:PCB板焊接式 PCB terminal

B:顶耳安装,插入式 Flange mount,plug-in

H:侧耳安装,插入式 Lateral flange,plug-in

E:螺丝安装,插入式 Screw mount,plug-in

选项: Options

无 None: 标准式 Standard

L:带灯LED(DC coil:green,AC coil:red)

D:二极管 Free wheeling diode

线圈电压 Coil voltage

6~220VDC

6~380VAC

产品特点 Features

- 体积小,灵敏度高; • 结构合理,用途广; • 多种规格,可配指示灯装置。
- Small size,high switching power,high sensitivity • A wide range of variations and options available

产品性能 Specification

形 式 Contact form		2C	3C	4C
触点 Contact	负载 Rated load	阻性 Resistive (AC-1)	5A/250VAC 30VDC	3A,5A/250VAC 30VDC
		马达 Motor (AC-15)	1/6HP,240VAC	
	切换功率(阻性) Operating power(Resistive)		1250VA 150W	
	接触电阻(初始) Contact resistance(Initial)		≤50mΩ	
	材 料 Material		银合金 Ag alloy	
	电气寿命(频率1S通, 1S断) Electrical life		≥10 ⁶ 次 cycles(1800 Ops/h)	
	机械寿命(频率300次/1分钟) Mechanical life		≥10 ⁷ 次 cycles(18000 Ops/h)	
吸合电压(25℃) Operate voltage(at 25℃)			DC:≤75%Rated voltage,AC:≤80%Rated voltage	
释放电压(25℃) Release voltage(at 25℃)			DC:≥10%Rated voltage,AC:≥30%Rated voltage	
最大电压(25℃) Max. Allowed voltage(at 25℃)			110%Rated voltage	
绝缘电阻 Insulation resistance			≥500MΩ (500VDC)	
线圈功率 Coil power consumption	DC(W)		0.9	
	AC(VA)		1.2	
吸合时间(额定电压) Operate time			≤20ms	
释放时间(额定电压) Release time			≤20ms	
初始耐压 Dielectric Strength	同极触点之间 Between contacts		1000VAC/1min(漏电流 1 mA) (Leakage current 1 mA)	
	异极触点之间 Between contacts(different pole)		1000VAC/1min(漏电流 1 mA) (Leakage current 1 mA)	
	触点与线圈间 Between contact and coil		2000VAC/1min(漏电流 1 mA) (Leakage current 1 mA)	
环境温度 Ambient temperature			-55~+70℃	
环境湿度 Humidity			35%~85%RH	
大气压力 Atmospheric Pressure			86~106KPa	
耐冲击 Shock resistance			10G(正弦半波脉冲: 11ms) (Half a wave of pulses of sine:11ms)	
耐振动 Vibration resistance			10~55Hz 双振幅:1.0mm	10~55Hz Dual amplitude:1.0mm
安装方式 Install model			插入式/印刷板焊接式	Plug-in terminals/PCB terminal
重量 Weight			35g	
配套插座 Matched relay socket		SYF08A SY08 TP58X	SYF08A-E SY08-0	SYF11A SY11 TP511X
			SYF11A-E SY11-0	SYF14A SY14 TP514X
同类产品 Like Products	富士通公司	HH52P	HH53P	HH54P
	OMRON	MY2	MY3	MY4

线圈规格(25°C) Coil type(25°C)

额定电压V.DC Rated voltage	6	9	12	24	36	48	110	220			
线圈电阻 Ω(±10%) Coil resistance	40	90	160	630	1500	2600	11000	42000			
额定电压V.AC Rated voltage	6	12	24	36	48	110	120	220	230	240	380
线圈电阻 Ω(±10%) Coil resistance	11.5	40	160	370	600	3750	3900	13000	15000	18790	42000

性能曲线图 Curve graph of performance

JQX-13F-MY2C,MY3C,MY4C (5A)

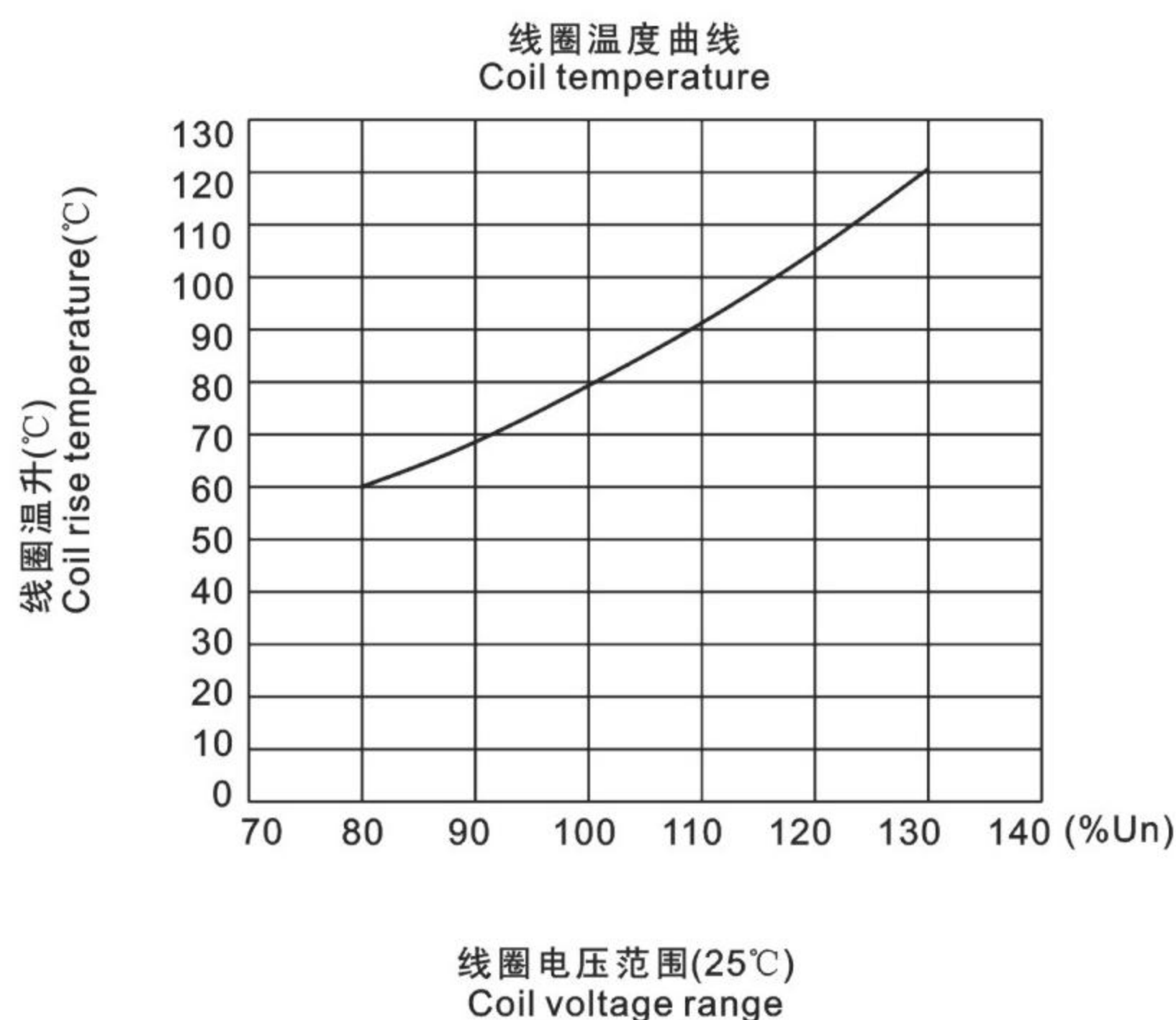
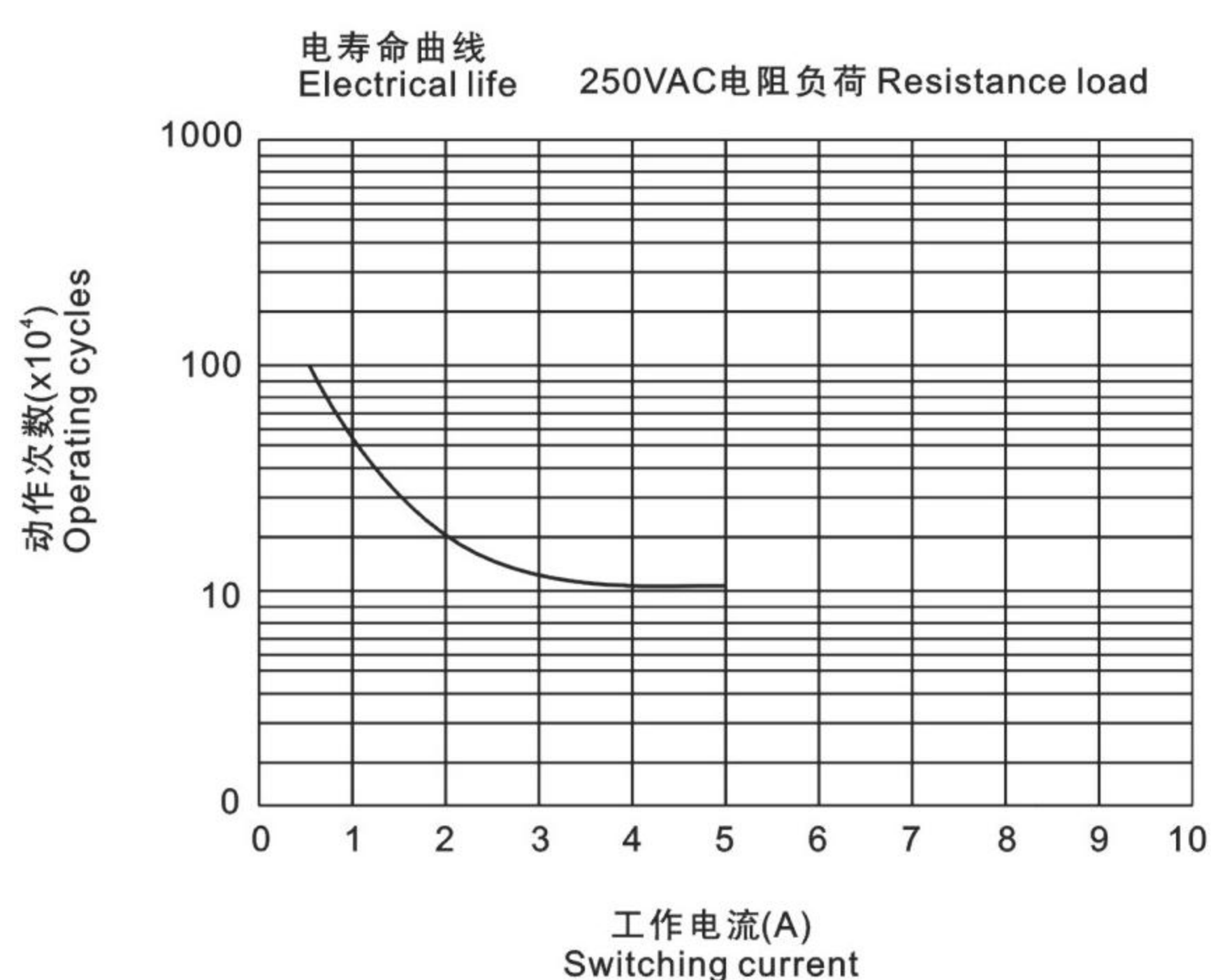

JQX-13F-MY4C (3A)

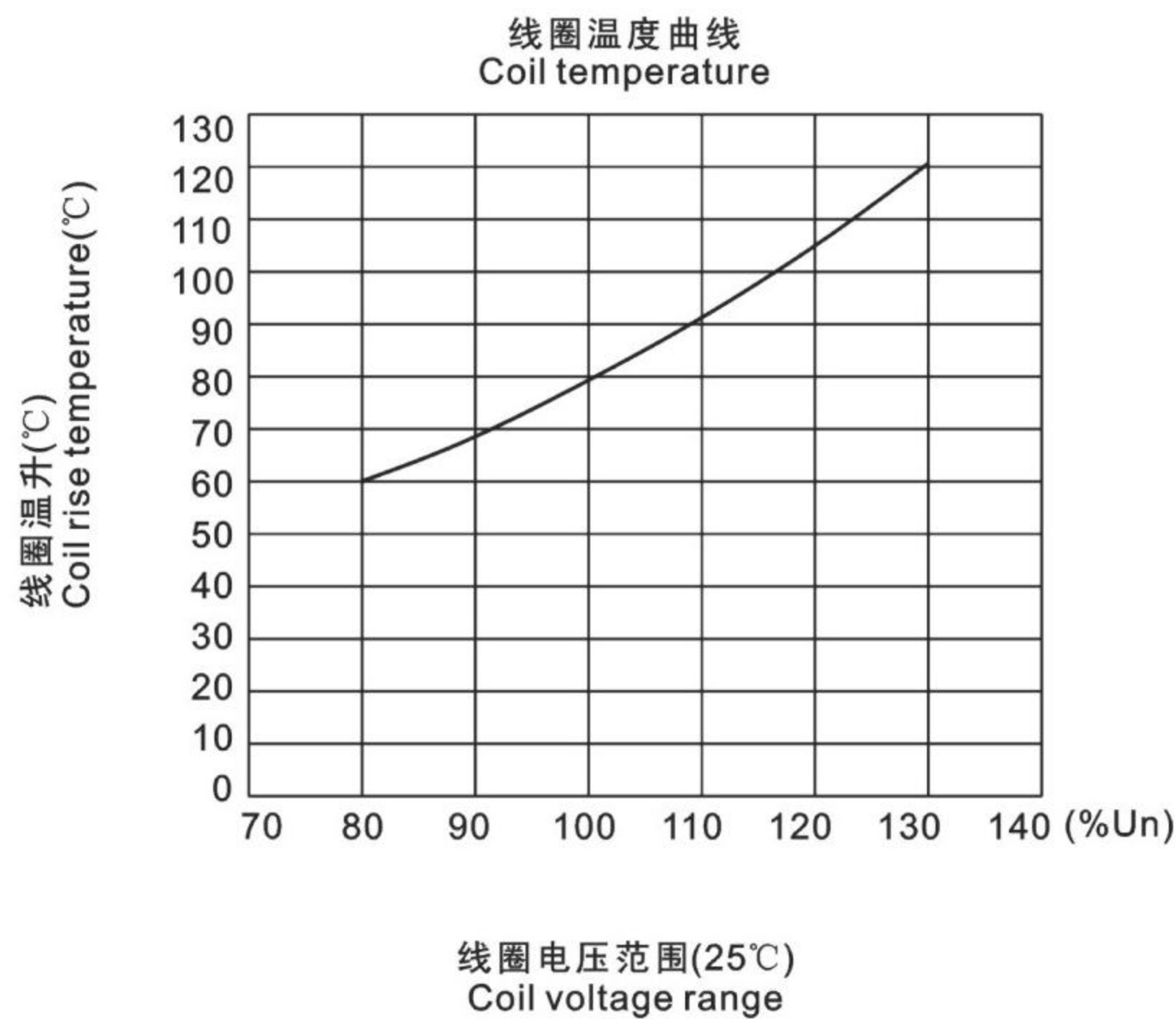
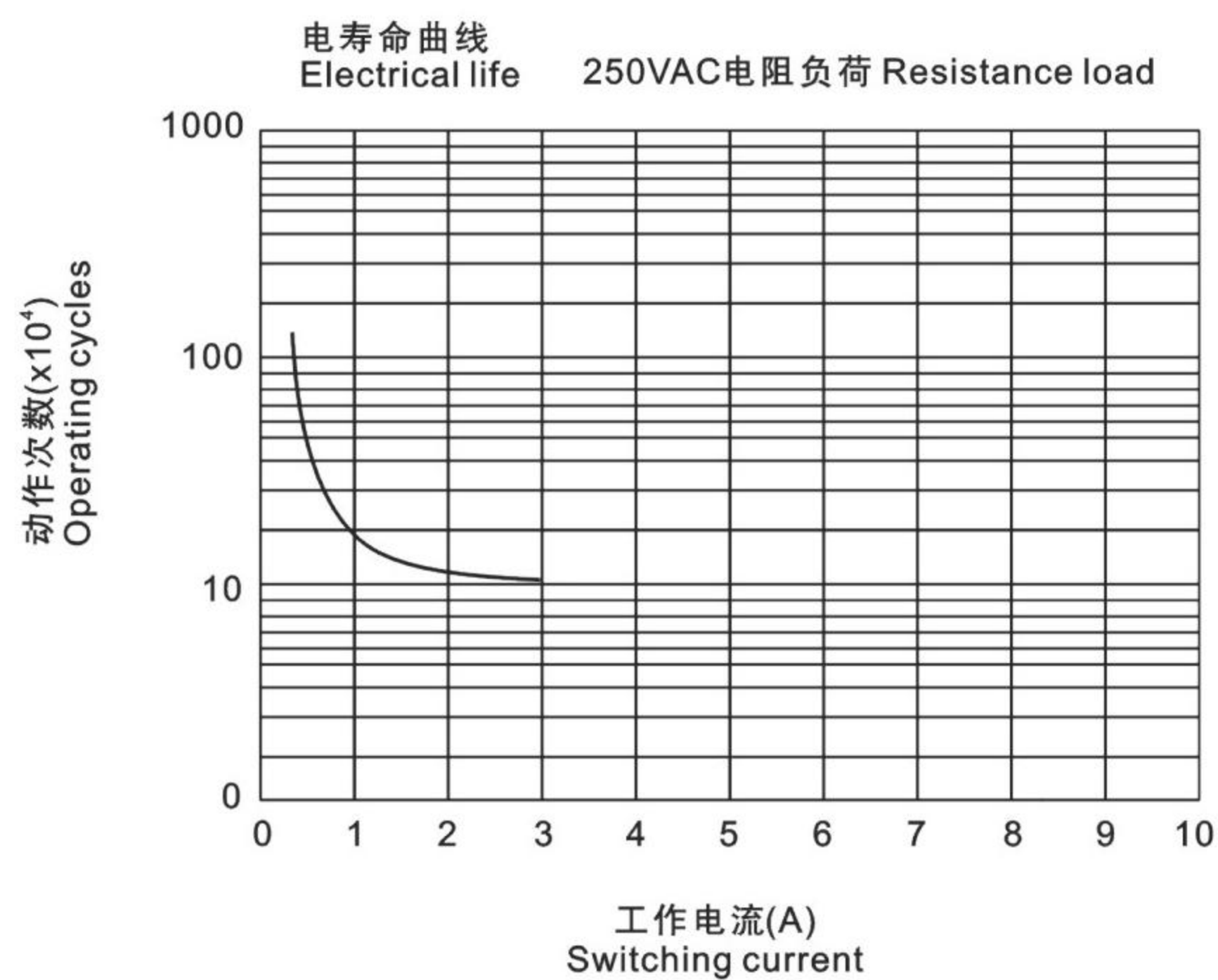

外形图、接线图、安装尺寸(mm) Dimension.Bottom View

JQX-13F-MY2C

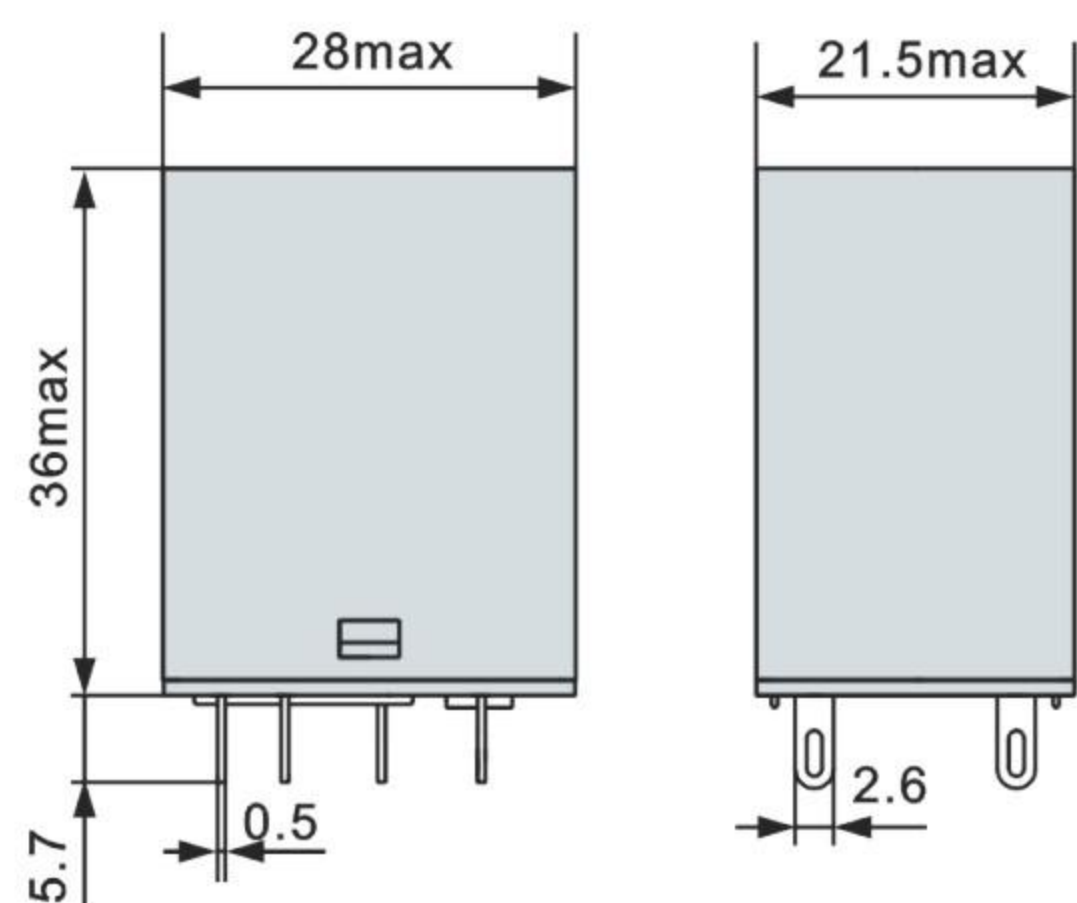

JQX-13F-MY2C

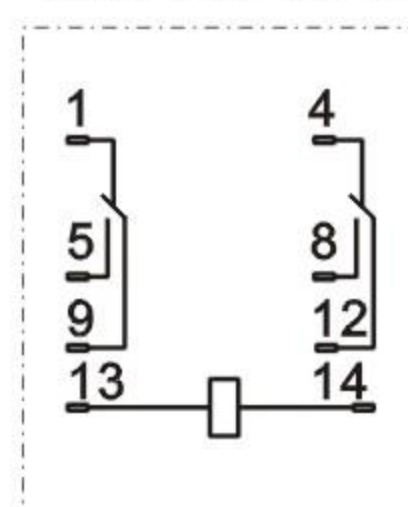

JQX-13F-MY2CL

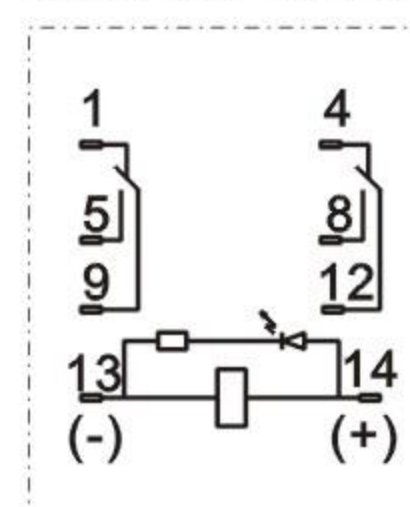

JQX-13F-MY2CD

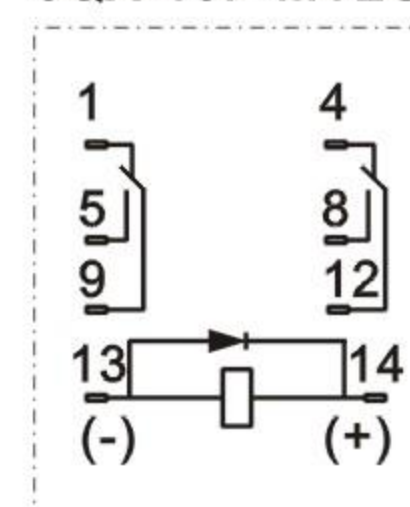

JQX-13F-MY2CLD

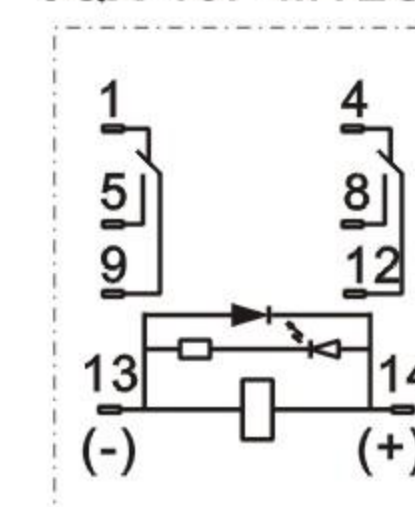

JQX-13F-MY3C

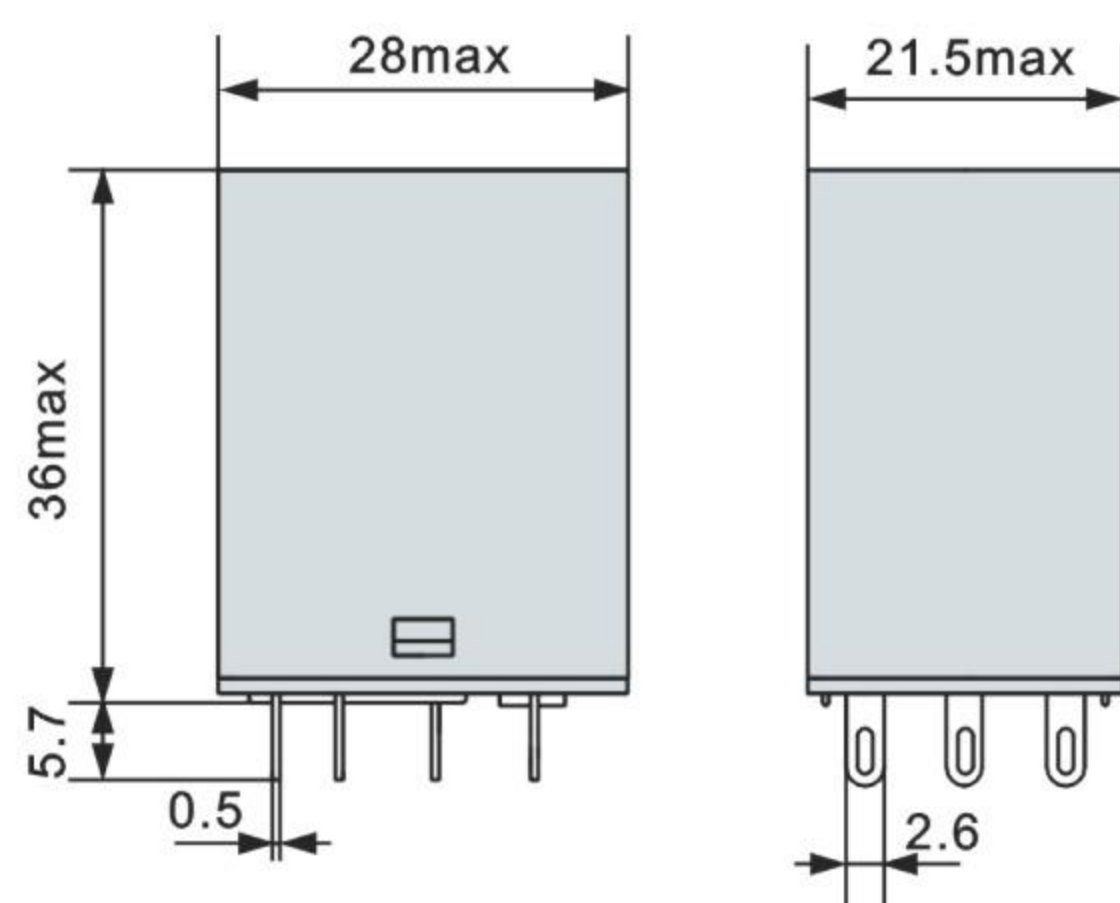

JQX-13F-MY3C

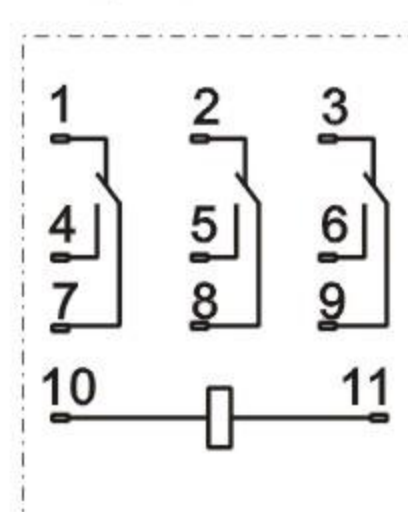

JQX-13F-MY3CL

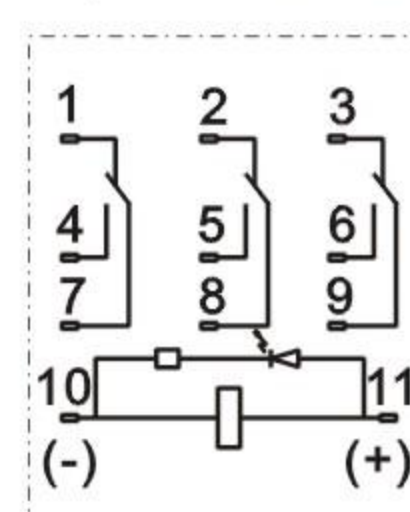

JQX-13F-MY3CD

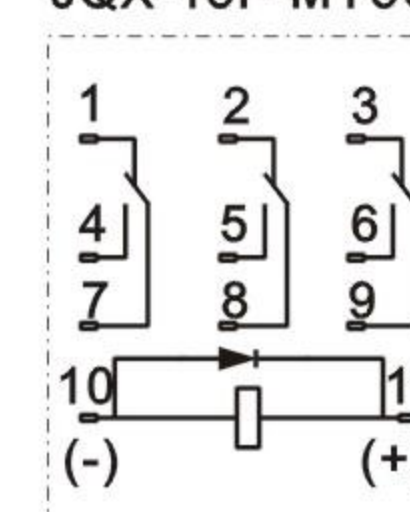

JQX-13F-MY3CLD

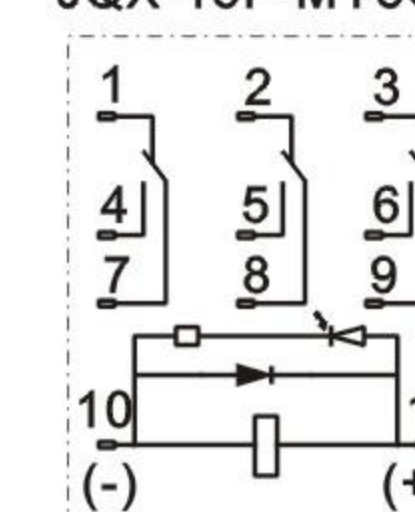

JQX-13F-MY4C

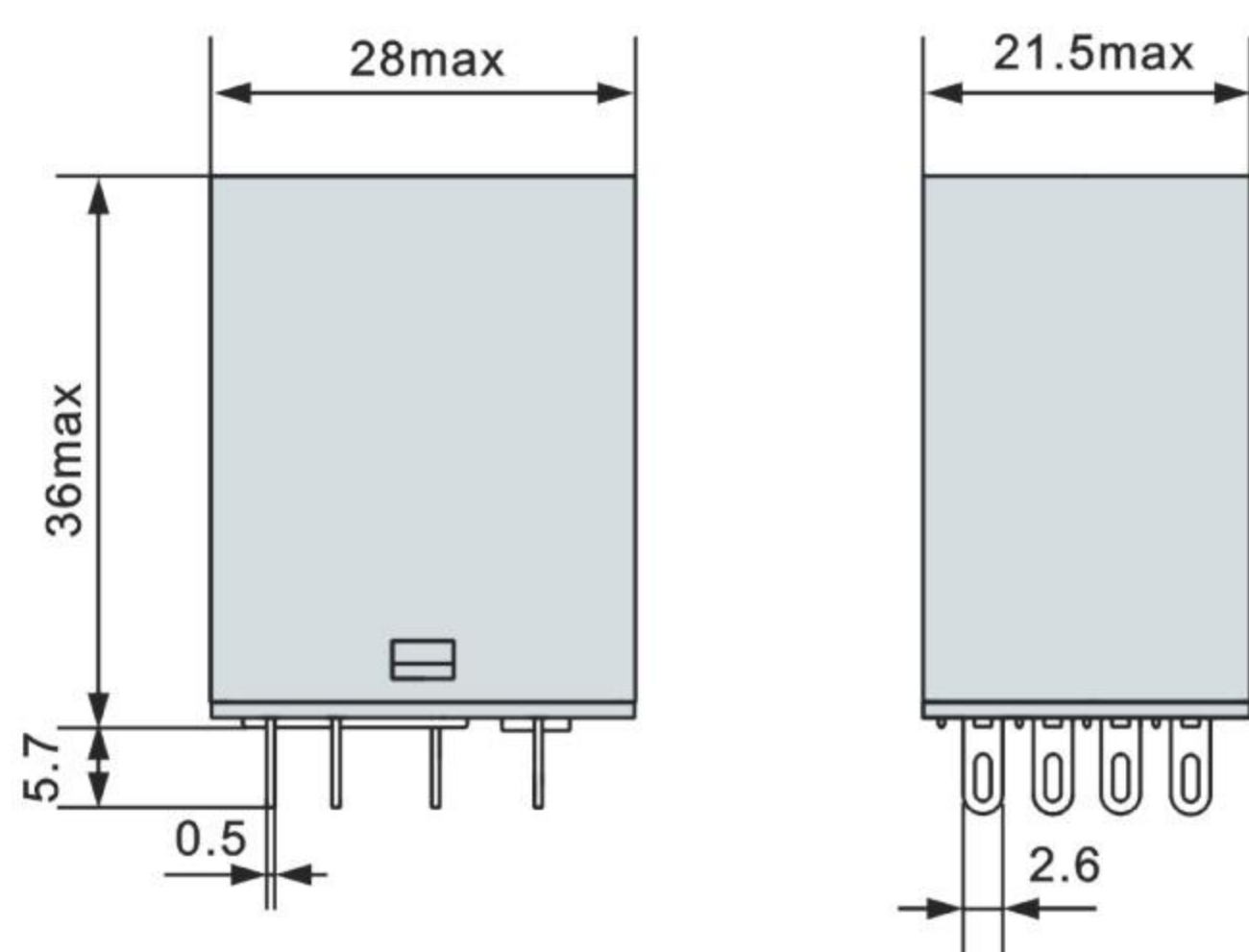

JQX-13F-MY4C

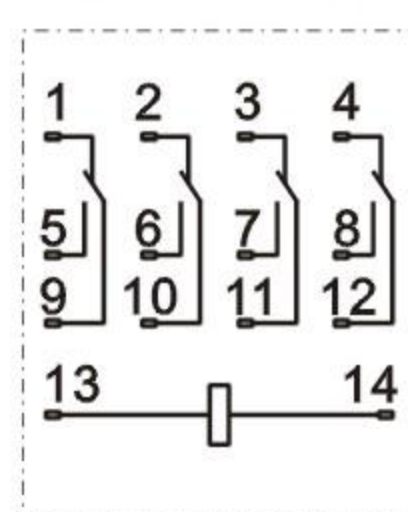

JQX-13F-MY4CL

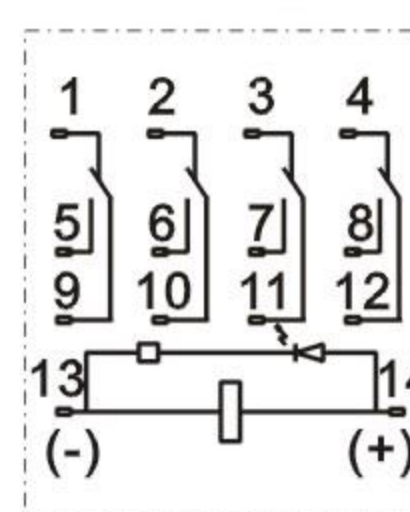

JQX-13F-MY4CD

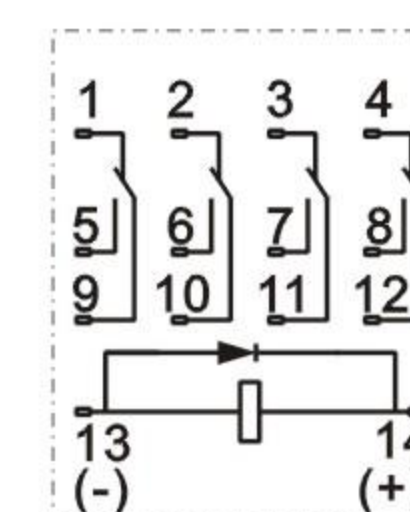

JQX-13F-MY4CLD

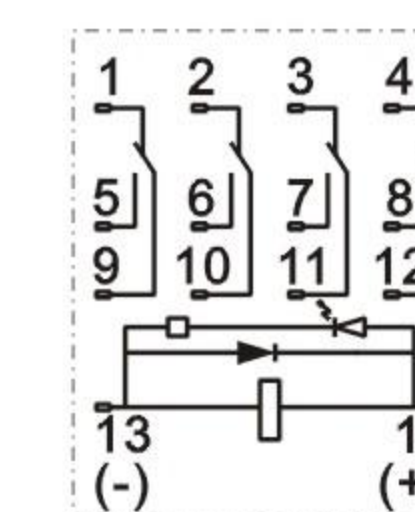

JQX-13F-MY2CP, JQX-13F-MY3CP, JQX-13F-MY4CP

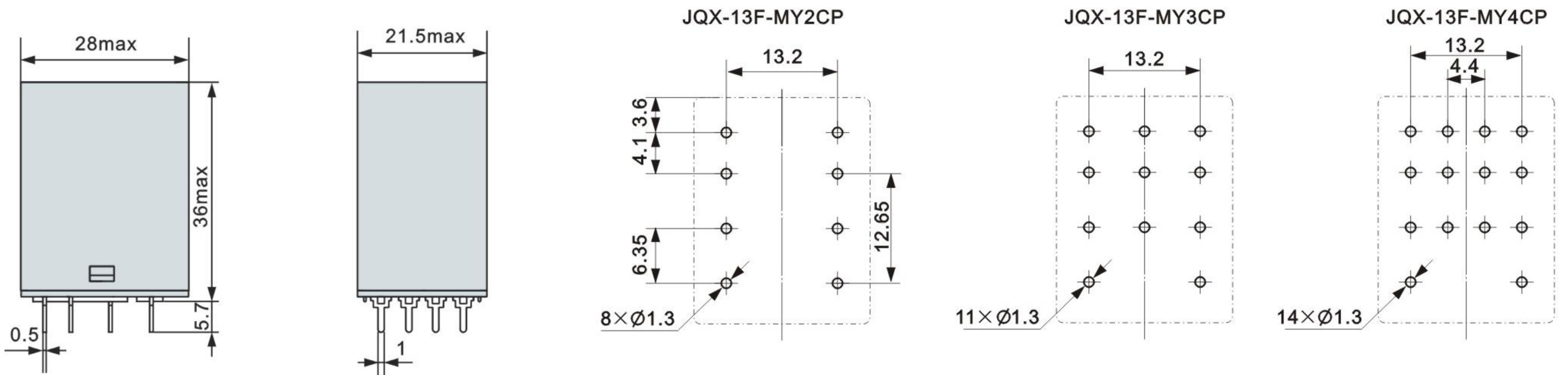

JQX-13F-MY2CB, JQX-13F-MY3CB, JQX-13F-MY4CB

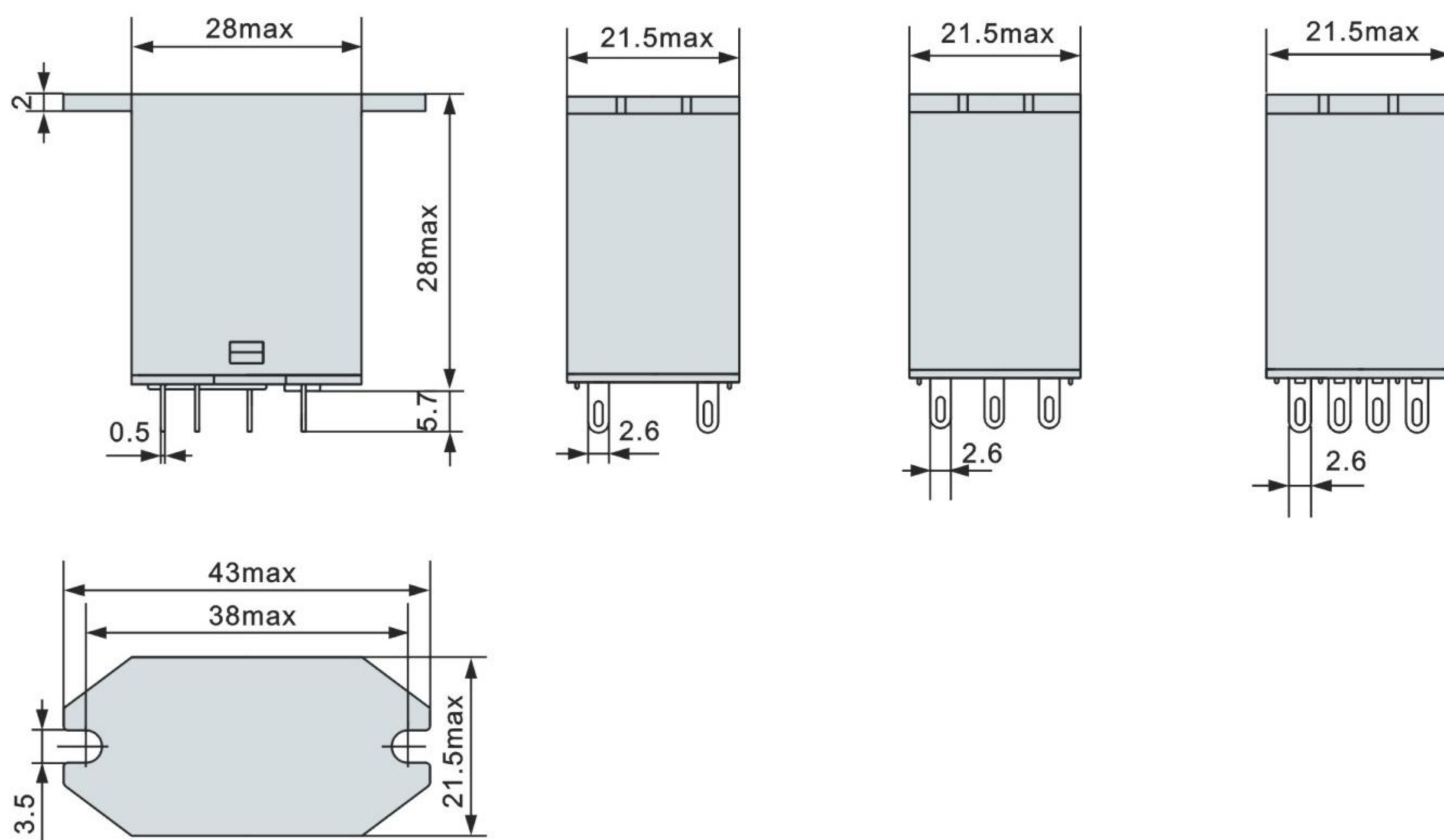

JQX-13F-MY2CH, JQX-13F-MY3CH, JQX-13F-MY4CH

