

Chapter 12

Use of Optical Sensor Units

12.1 General description

Optical sensor units with sophisticated features can be created using the light emitting/receiving elements described in previous chapters, and combining these with optical systems containing lenses and other optical devices, along with analog signal processing circuits and microcomputer software etc. In this chapter, we shall explain the following typical optical sensor units:

- (1) Distance measuring sensors: for measuring the distance to a reflecting object;
- (2) Dust sensors: for measuring the dirtiness of air due to micro-particles such as dust;
- (3) Color/Toner density sensors: for measuring color/toner density for color copiers etc.

These optical sensor units have already undergone:

- (1) Optical design using optical simulation technology
- (2) Analog circuit design including high-precision signal processing and sensitivity ad-

justment

(3) High-density design for reducing size and weight

Thus they have already been subjected to the optical and circuit design necessary when using individual light emitting/receiving elements in combination, and their performance as a unit is guaranteed. Therefore, a high-precision high-sensitivity sensor system can be easily realized by using these optical sensor units.

12.2 Distance measuring sensor

Optical sensors that detect whether or not the received intensity of light exceeds a specified value have been widely used as sensors for detecting the presence of objects, even people. However, when using a conventional optical sensor for detection, if the color and reflectance of the detected object appear to be inconstant, detection precision may be poor, or misdetection may occur. Hence this type cannot satisfy the market need for higher accuracy.

In the distance measuring sensors discussed here, there is no dependence on the color or reflectance of the detected object as mentioned above, with detection being achieved by optically measuring the distance to the object.

12.2.1 Principle of operation of distance measuring sensor

A distance measuring sensor is an optical device that applies the principle of triangulation, shown in Fig. 12-1. Light emitted from an infrared emitting diode passes through a projection lens designed to yield LED light with exceptionally sharp directionality, and irradiates the detection object. The light is diffusely reflected from the object, and if the incident light is concentrated on a light-receiving element with a light-receiving lens, then the position of the incident light spot on the element will vary according to the distance to the object. The distance to the detection object can thus be found by electrically detecting this incident light spot position.

In this section, "LED" refers to an infrared LED. Referring to Fig. 12-1, if we let A be the distance (base length) between the centers of the projection lens and light receiving lens, and let f be the focal distance of the light receiving lens, and geometrically find the incident light spot position x_1 using the distance ℓ_1 to the detection object, then the result is:

<Fig. 12-1> Principle of triangulation distance measuring method

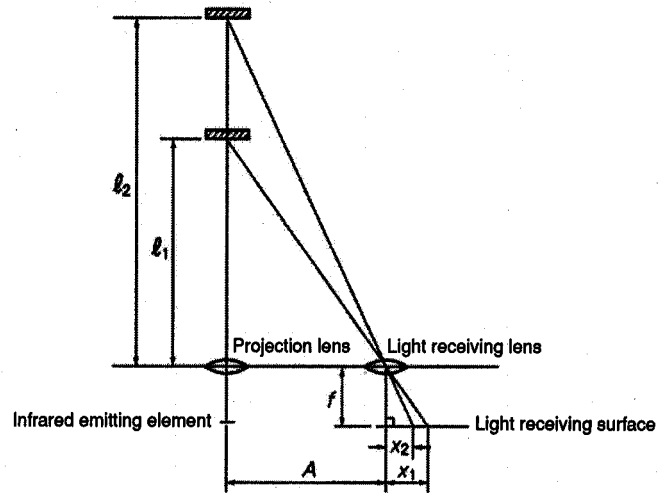

$$x_1 = \frac{A \cdot f}{\ell_1}$$

If the measurable distance range is set from ℓ_1 to ℓ_2 , then the movement distance Δx of the incident light spot can be expressed:

$$\Delta x = x_1 - x_2 = \left(\frac{1}{\ell_1} - \frac{1}{\ell_2} \right) \cdot A \cdot f$$

Using this formula, it is possible to set the A and f values to determine the measurable distance range while taking into consideration the effective light reception length of the light receiving surface.

A position sensitive detector (PSD), a specifically designed application of photodiodes, is used as the light-receiving element for electrically detecting the incident light spot position.

As explained in section 5.5 of chapter 5, the current ratio of the two outputs of a PSD corresponds to the incident light spot position, so the distance to the detection object can be determined electrically by calculating the current ratio of the two outputs.

12.2.2 Distance measuring sensor characteristics and appearance

● Internal circuit configuration

Fig. 12-2 shows the circuit block diagram of the distance measuring sensor.

The LED drive circuit section causes the LED to emit infrared in a pulsed fashion. In order to raise the precision of the sensor distance measurement, the circuit is designed to drive the LED 32 times per distance measuring operation. The PSD output is read 32

<Fig. 12-2> Circuit block diagram of a distance measuring sensor

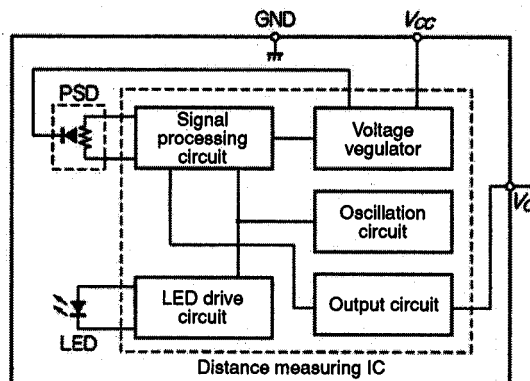

<Table 12-1> List of typical distance measuring sensor models

		Form of output	
		Analog voltage output	H/L output (Detection distance)
Distance measuring range	4 to 30 cm	GP2D120XJ00F	GP2D150AJ00F (15 cm)
	10 to 80 cm	GP2D12J0000F	GP2D15J0000F (24 cm)
	20 to 150 cm	GP2Y0A02YKF	GP2Y0D02YKF (80 cm)

times in synchronization with the LED emission timing, and the average of the calculated values is output.

The signal processing circuit section is comprised of several individual circuits with various functions. There is an AC amplifier for eliminating PSD output current due to ambient interference light, an amplifier for increasing the amount of PSD output current variation (as the signal) during LED pulse emission, a calculation function for calculating the ratio of the two signal currents the from PSD, and an averaging function for calculating the mean of the 32 calculated values.

The oscillator controls operation of the entire circuit — synchronizing operation of the signal processing circuit with LED drive. Distance measuring sensors are available with two forms of output: an analog voltage that is proportional to the distance to the reflecting (detection) object; and a logical H/L output type that outputs a state depending on whether the reflecting object is beyond or before a specified distance.

● Features and appearance

Table 12-1 shows a list of typical distance measuring sensor models. In the table, the detection distance for H/L output indicates the distance for switching between detection and non-detection. In practical applications, the range and output form must be selected according to the particular application and purpose. The appearance of the GP2D12J0000F and GP2D15J0000F is shown in Fig. 12-3, and the characteristics in Fig. 12-4. As can be seen, the

<Fig. 12-3> Appearance of the GP2D12/15J0000F

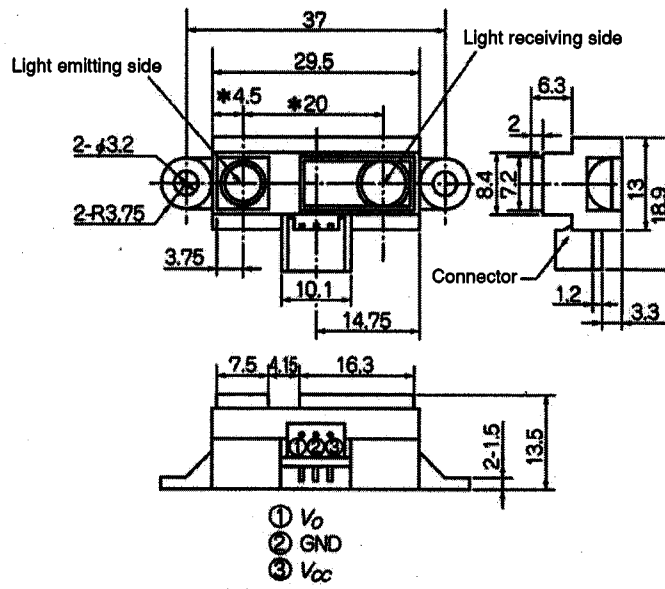

The asterisk (*) indicates the lens center position dimension

<Fig. 12-4> GP2D12/15J0000F characteristics

• GP2D12J0000F

Parameter	Symbol	Characteristic value
Operating power supply voltage	V_{cc}	4.5 to 5.5 V
Distance measuring range	L	10 to 80 cm
Supply current	I_{cc}	MAX 50 mA
Output	—	Analog output (Indicated at right)
Operating temperature	T_{opr}	-10 to +60 °C

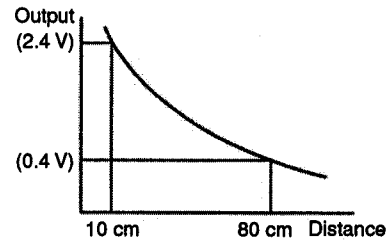

• GP2D15J0000F

Parameter	Symbol	Characteristic value
Operating power supply voltage	V_{cc}	4.5 to 5.5 V
Supply current	I_{cc}	MAX 50 mA
Judgement distance	L	TYP 24 cm
Output	—	Digital output (Indicated at right)
Operating temperature	T_{opr}	-10 to +60 °C

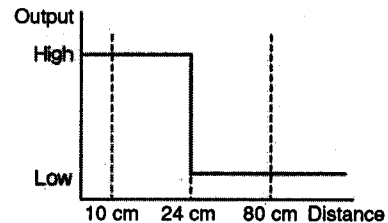

GP2D12J0000F provides an analog output proportional to the distance to the detection object, whereas the output of the GP2D15J0000F is logical High or Low according to whether the detection object is further or closer than the specified distance (24 cm).

The distance characteristics of the output of the GP2D12/15J0000F are almost completely unaffected by the detection object color and reflectance, as detailed above. Conversely, with sensors that detect the intensity of reflected light, there are design difficulties that have to be taken into consideration, such as the following two points:

<Fig. 12-5> Filter installation on front of distance measuring sensor

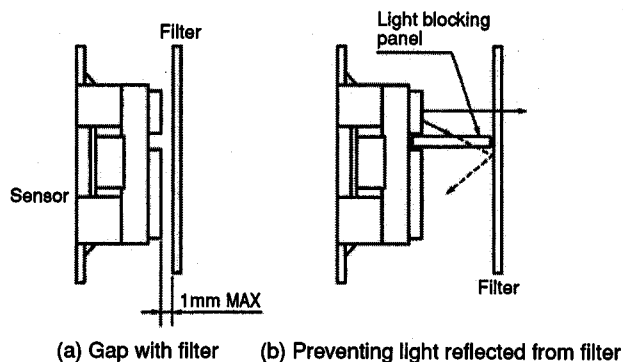

- ▶ An acceptable *S/N* is difficult to obtain if there is a small difference between the distance of objects to be detected and the distance of objects that are not to be detected;
- ▶ Detection distance can vary due to degradation in the amount of emitted infrared as the unit ages.

The above disadvantages of such systems are of no consequence when using a distance measuring sensor.

12.2.3 Precautions for distance measuring sensor use

The following are precautions for ensuring peak performance from the distance measuring sensor.

- **In case of installing a filter on the front of the distance measuring sensor**

The LED light emission wavelength of the distance measuring sensor is approximately 850 ± 70 nm. When installing a filter on the front of the sensor, it is necessary to select a material that has a spectral transmittance that allows the infrared to adequately pass through. Also, it is essential to avoid using materials that contain dispersing agents or impurities that scatter light.

To avoid scattering of light at the filter surface, a mirror finishing should be employed on both front and back of the filter surfaces. If infrared from LED, or infrared reflected from a reflecting object is scattered by the filter, it will be impossible to obtain accurate distance measurement.

Install so that the distance between the distance measuring sensor and filter is as short as possible (less than 1 mm, see Fig. 12-5 (a)). If the gap is wider, part of the infrared will be regularly reflected by the filter and enter the sensor light receiving section, and it may become impossible to obtain accurate distance measurement. If the gap has to be wide, be

<Fig. 12-6> Sensor mounting direction for moving object

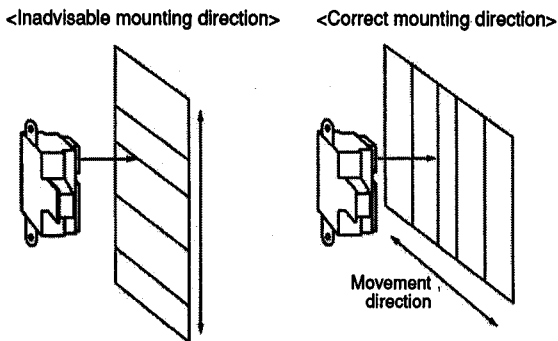

<Fig. 12-7> Reflected light paths from a mirror-reflecting object

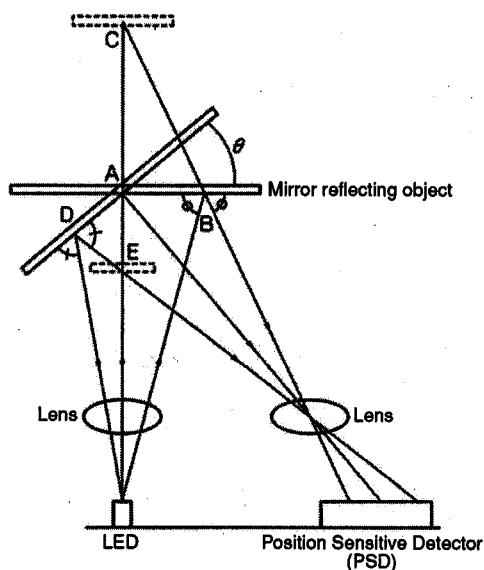

sure to include a light blocking panel between the sensor and filter, so to ensure that LED light does not regularly reflect from the filter and enter the light receiving section (Fig. 12-5 (b)).

● **Sensor mounting direction for moving objects**

When detecting an object which moves in a direction perpendicular to the sensor light axis, prevent distance measuring error by re-orientating the sensor or object so that the movement direction of the reflecting object is orthogonal to the line between the centers of the sensor light receiving and emitting lenses (Fig. 12-6).

● **Sensor output during mirror reflection**

Distance measuring cannot be successfully performed with reflecting objects having mirror-like qualities (glass or mirrors, etc.) and hence no dispersed reflection component. In Fig. 12-7, if there is a mirror reflecting object at point A, the mirror reflected light from point B will enter the light receiving element, but the incident light spot position on the light receiving element in this case will be the same as if there were a dispersion reflecting

<Fig. 12-8> Sensor mounting direction when detecting a reflecting object

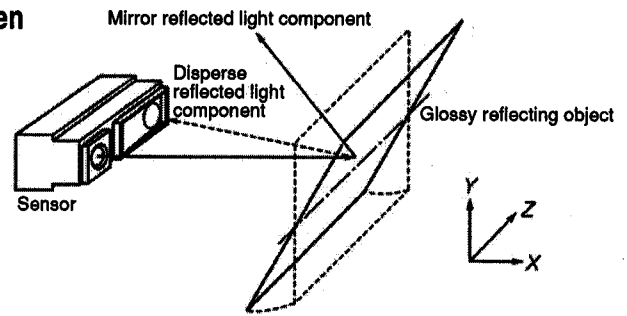

object at point C, and the distance measuring output will indicate this incorrect position.

If the mirror reflecting object is inclined at an angle θ about point A, then the mirror reflected light from point D is incident on the light receiving element, and the distance measuring output is the same as if there were a dispersion reflecting object at point E.

● **Sensor output when there is a glossy reflecting object with a dispersion reflecting component**

When distance measuring is performed with glossy reflecting objects having a dispersion reflecting component (painted metal, molded plastics, colored vinyl etc.), the reflected light due to the gloss from the reflected object (i.e. mirror reflection) may affect the distance measuring output.

In this situation, the mirror reflected component is allowed to escape in the Y direction by inclining the sensor light axis relative to the glossy reflecting object, as shown in Fig. 12-8. Thus, the set-up ensures that only the dispersed reflected component is incident on the light-receiving element, and an accurate distance measurement can be obtained.

● **Interference light**

When light from the sun or a light source such as a tungsten lamp is incident on the sensor's light receiving surface, accurate distance measuring may become impossible. Light that is directly incident from these sources must therefore be considered in design.

12.3 Dust sensor

In recent years, dust sensors that can optically detect the particle levels in air have become popular in air purifiers that remove particles in air such as tobacco smoke, house dust and pollen. Today some air-conditioners are even equipped with an air purification function. By using a dust sensor, it is possible to automatically start, stop and adjust the strength of the air purification function.

<Fig. 12-9> GP2Y1010AU0F internal layout diagram

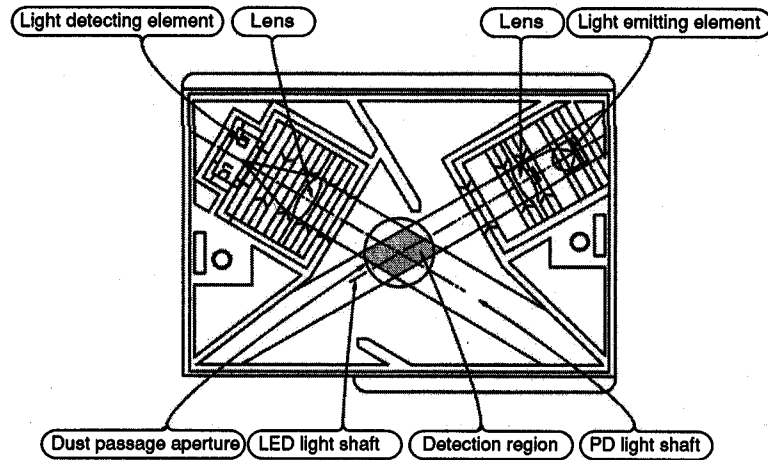

12.3.1 Dust sensor detection principle

A dust sensor is a reflecting type device that detects the amount of light reflected from particles in the air. Fig. 12-9 shows the internal structure of the GP2Y1010AU0F dust sensor. Light emitted from the infrared emitting element is made almost parallel by a lens arrangement in front of the light emitting element. There is also a lens in front of the light detecting element (photodiode), and the unit is designed so that only the incident light perpendicular to this lens is passed to the light emitting element. The point where the infrared emitting element (LED) light shaft intersects the light detecting element (PD) light shaft is the detection region. If there are airborne particles like tobacco smoke or house dust in the detection region, then the light from the light emitting element irradiates the particles, and the light reflected from these particles is directed to the light-receiving element.

The more particles there are in the detection region, the more light is reflected to the light-receiving element.

The output current of the light-receiving element is amplified and output as an analog voltage corresponding to the amount of particles in the air (i.e., dust concentration). In fact, even when there are no particles in the detection region the output voltage is not zero; this is because light from the light emitting element is reflected by the inner walls of the sensor case, becoming stray light that impinges on the light-receiving element.

<Fig. 12-10> GP2Y1010AU0F dust sensor block diagram and connection circuit example

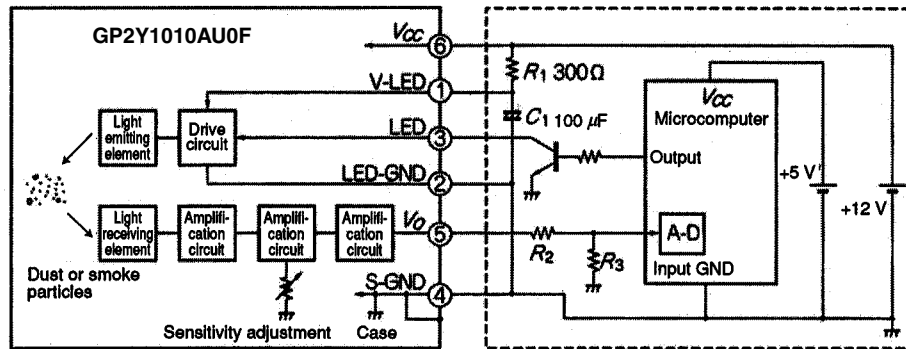

<Table 12-2> GP2Y1010AU0F Electro-optical characteristics

Parameter	Symbol	Characteristic value
Operating power supply voltage	V_{cc}	12 V \pm 1.8 V
Detection sensitivity	K	12 V / (0.1 mg/m ³) \pm 30%
Output terminal	Output terminal with no dust	V_{s0} MAX 2.5 V
	Output voltage range	V_{out} MIN 10.2 V ($R_L = 4.7$ k Ω)
LED terminal current	I_{LED}	MAX 20 mA
Current consumption	I_{cc}	MAX 20 mA

(Note) Recommended input conditions for LED input terminal

Parameter	Symbol	Recommended value	Units
Pulse cycle	T	10 \pm 1	ms
Pulse width	P_w	0.32 \pm 0.02	ms

12.3.2 Dust sensor characteristics and appearance

● Internal block diagram and connection circuits

Fig. 12-10 shows the internal block diagram and a connection circuit example for the GP2Y1010AU0F dust sensor.

The infrared emitting element (LED) must be illuminated in pulses by an input signal from terminal no. 3. This is achieved using the resistor R_1 and capacitor C_1 , and their values were carefully calculated for optimum performance. Indeed, if the values of R_1 and C_1 are changed, the sensor may not operate correctly, or it may be impossible to obtain characteristics conforming to specifications.

A pulsed output current synchronized with LED pulse illumination is monitored from the light detecting element. In the signal processing circuit subsequent to the light-receiving element, first only the pulsed variation component of the light-receiving element output current is extracted and amplified, and next there is a sensitivity adjustment circuit that ensures that the amount of variation of the sensor output voltage (relative to the change in dust concentration) is fixed. The signal then passes through a final stage amplification circuit, and a voltage value corresponding to the dust concentration is output as a pulsed voltage that varies in an analog fashion.

<Fig. 12-11> Appearance of the GP2Y1010AU0F (Units: mm)

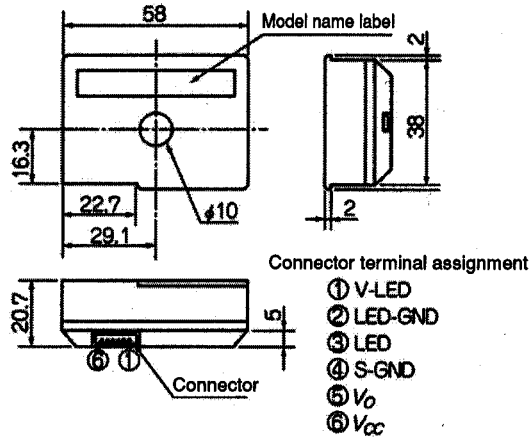

<Fig. 12-12> Typical dust concentration characteristics of the GP2Y1010AU0F

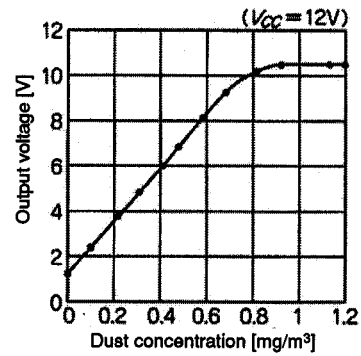

<Fig. 12-13> Output of the GP2Y1010AU0F due to tobacco smoke and house dust

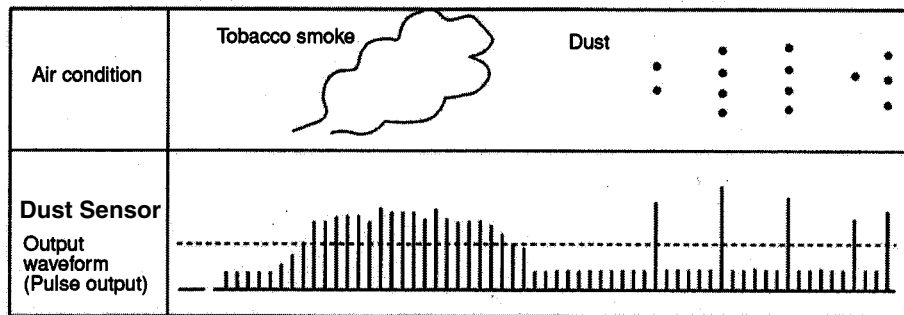

● Characteristics and appearance

The GP2Y1010AU0F dust sensor electro-optical characteristics are shown in table 12-2. The rate of change in output voltage relative to a change in the dust concentration of the air is indicated as the detection sensitivity. An example of the dust concentration characteristics of GP2Y1010AU0F is shown in Fig. 12-12.

12.3.3 Identification of tobacco smoke and house dust

Using the output voltage of the GP2Y1010AU0F, it is possible to identify whether the detected particles in the air are tobacco smoke or house dust. Fig. 12-13 shows the differences in the GP2Y1010AU0F output when tobacco smoke and house dust are detected.

When tobacco smoke first spreads through the air and reaches the detection area of the GP2Y1010AU0F, the sensor output voltage (pulse output voltage) increases.

Tobacco smoke is continuously present in the sensor detection area, and the amplitude of

the voltage output each time the sensor LED illuminates in pulsed fashion corresponds to the dust concentration (tobacco smoke concentration) when the LED is lit. When a fixed concentration of tobacco is attained, the sensor output voltage assumes a fixed value. When the dust concentration drops due to ventilating the room or operating an air purifier, the sensor output voltage also gradually drops.

In contrast, particles of house dust (from futons, sitting cushions or clothes) are not always present in the sensor detection area as is tobacco smoke; they in fact appear in the detection area sporadically. Therefore, as further shown in Fig. 12-13, sensor output when detecting house dust is high when there is house dust present in the sensor detection area, and low when dust is not present, so the sensor output voltage repeatedly varies between extremes in a short time.

Thus, when detecting tobacco smoke and when detecting house dust, there is a distinctive difference in the time fluctuation of the sensor output voltage, so tobacco smoke and house dust can be identified by using software to determine the variation of sensor output voltage against time.

12.3.4 Precautions when using dust sensors

The following are precautions that should be taken to ensure peak performance of the dust sensor during use.

● Input signal for LED drive

For the LED pulse illumination input signal, use a cycle and pulse width value in the range recommended in the input conditions of table 12-2 (including note).

If the cycle, T , is short, this may have an effect on LED life, and if it is long, airborne particles like house dust may pass through the sensor's detection area while the LED is off, and not be detected. If the pulse width, Pw , is long, this may too affect LED life, and if it is short, the signal processing circuit may not be able to respond adequately.

● Dust deposition on sensor

If dust, deposited on the case inner walls of the sensor, is suddenly released, the sensor output will remain constantly in the detecting state. In cases like this, the sensor output will return to the normal value if dust is vacuumed away with a vacuum cleaner.

When designing the equipment housing, use structural or mechanical techniques to prevent large debris (such as lint and long threads) from entering the sensor.

● Sensor output correction

With the GP2Y1010AU0F there is a variation between individual products in the output voltage with no dust. Therefore, when the product is used in mass production, there will be a corresponding variation in the detected dust concentration value if the threshold level voltage for detection/non-detection is fixed. Furthermore, the amount of infrared emitted by an infrared emitting diode drops with long-term energization. Hence the output voltage with no dust and the detection sensitivity of the GP2Y1010AU0F will drop, and the detected values for dust concentration change compared to when new.

To deal with this difference between sensors and variation over time, we recommend performing the following corrections by software:

<For variation between individual sensors>

In order to reduce variation in the detected dust concentration attributable to variations in the no dust output voltage of each product, the value of the no dust output voltage is stored in memory, and detection is set to occur when the sensor output voltage value rises by at least a specified amount over the memory value.

Methods of storing the output voltage with no dust in memory include: storing it at the beginning in non-volatile memory such as E²PROM, or storing the minimum sensor output voltage in RAM while the equipment power is on.

<For variation over time>

If the aforementioned value for output voltage with no dust is stored in non-volatile memory, then the minimum sensor output voltage while equipment is on can be compared with the memory value, and the variation over time of the amount of light emitted by the infrared emitting diode can be determined. If, for example, the amount of infrared emitted drops by 20%, then an effective control method is to reduce the threshold level voltage for detection/non-detection by 20%.

If non-volatile memory is not used, another method is to lower the threshold level voltage a little if the sensor output does not enter the detection state continuously for a few tens of minutes — regardless of whether the equipment power supply is on.

● Sensor mounting direction

If interference light from the name or ratings labels on the GP2Y1010AU0F enters the sensor, it may affect the output voltage. To prevent such an occurrence, locate label surfaces so that they are away from the air apertures of the equipment.

Also, to keep deposition of dust on lenses in the sensor from affecting characteristics, design the unit so that the lenses on the front of the light receiving/emitting elements face downward, and the sensor connector attachment surface faces down.

<Fig. 12-14> Reflecting sensor optical system

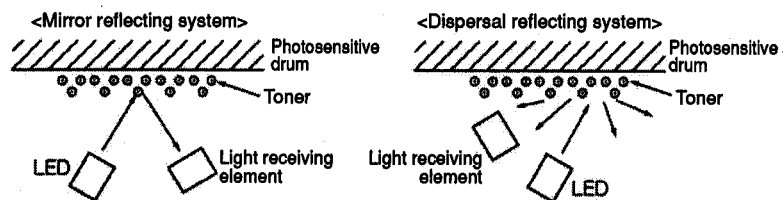

● **Sensitivity adjustment**

The sensitivity adjustment variable resistor (VR) is factory adjusted. Do not adjust it because this may cause characteristics to fail to meet specifications.

● **Case disassembly**

Do not remove or disassemble the case, because this may cause characteristics to fail to meet specifications after reassembly.

12.4 Color toner density sensor

In digital color equipment such as color copiers and color laser beam printers (LBP), the four color toners — Yellow (Y), Magenta (M), Cyan (C) and Black (K) — must be applied to the photosensitive drum in the appropriate concentration to achieve proper reproduction of colors.

The color toner density sensor described here is a reflective optical system sensor for detecting toner density on a toner transfer medium such as a photosensitive drum or transfer belt.

12.4.1 Optical system of color toner density sensor

Optical systems for reflective optical sensors can be divided into two types: the mirror reflecting system; and the dispersal reflecting system. As shown in Fig. 12-14, for the sensor in the mirror reflecting system, a light receiving element is placed in a position where it receives regularly reflected (mirror reflected) light from the infrared emitting element (LED). For the sensor in the dispersal reflecting system, a light receiving element is placed at a position where it does not receive regularly reflected light from the LED, but only dispersed reflected light.

Fig. 12-15 shows the characteristics obtained when detecting toner density using each system.

<Fig. 12-15> Toner density detection characteristics using the mirror reflecting system and the dispersal reflecting system

Background	Detected toner	Output characteristic	
		Mirror reflecting system	Dispersal reflecting system
Photosensitive drum	Color toner	<input checked="" type="checkbox"/> Narrow detectable range	<input checked="" type="checkbox"/> Appropriate for detection
		<p>Detectable range Light reception amount 0.4 Toner amount [mg/cm²]</p>	<p>Detectable range Light reception amount 1.0 Toner amount [mg/cm²]</p>
	Black toner	<input checked="" type="checkbox"/> Appropriate for detection	<input checked="" type="checkbox"/> Appropriate for detection
		<p>Detectable range Light reception amount 0.6 Toner amount [mg/cm²]</p>	<p>Detectable range Light reception amount 0.6 Toner amount [mg/cm²]</p>
Transfer belt	Color toner	<input checked="" type="checkbox"/> Narrow detectable range	<input checked="" type="checkbox"/> Appropriate for detection
		<p>Detectable range Light reception amount 0.4 Toner amount [mg/cm²]</p>	<p>Detectable range Light reception amount 1.0 Toner amount [mg/cm²]</p>
Transfer belt	Black toner	<input checked="" type="checkbox"/> Appropriate for detection	<input checked="" type="checkbox"/> Output is low, detection is impossible
		<p>Detectable range Light reception amount 0.6 Toner amount [mg/cm²]</p>	<p>Detection impossible Light reception amount Toner amount [mg/cm²]</p>

In the infrared ($\lambda_p = 950 \text{ nm}$) range, the Y, M and C color toners each have the same dispersal reflectance, which is higher than that of the photosensitive drum.

When detecting color toner density on a photosensitive drum, the mirror reflected light from the drum surface decreases as the amount (density) of toner increases, whereas the dispersal reflected light increases due to the difference in dispersal reflectance of the color toner and photosensitive drum. Therefore, the dispersal reflecting optical system enables density detection over a wider toner density range than the mirror reflecting optical system. When detecting K (Black) toner density on the photosensitive drum, mirror reflected light from the drum surface decreases as the amount (density) of K toner increases, and dispersal reflected light decreases due to the difference in dispersal reflectance of the photosensitive drum and K toner. The mirror reflecting optical system yields greater varia-

<Fig. 12-16> Appearance of a color toner density sensor

GP2TC1J0000F

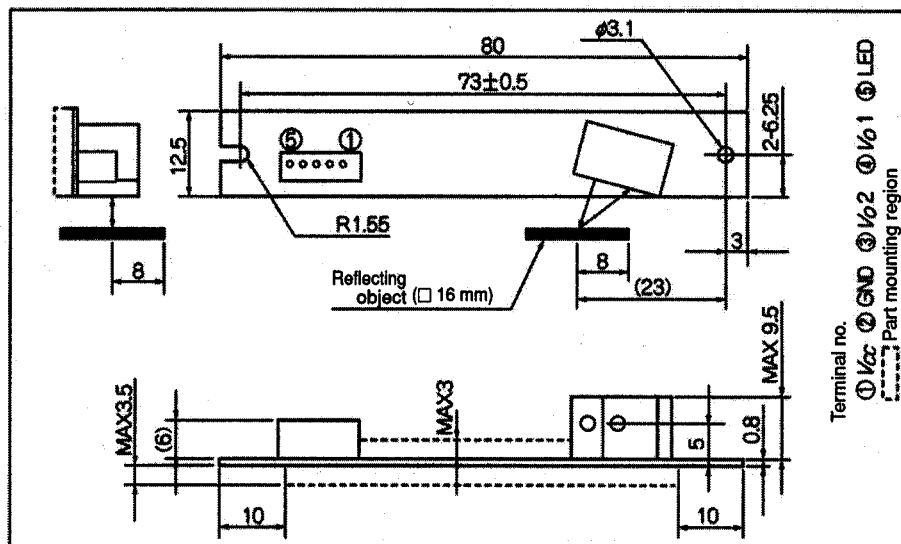

GP2TC2J0000F

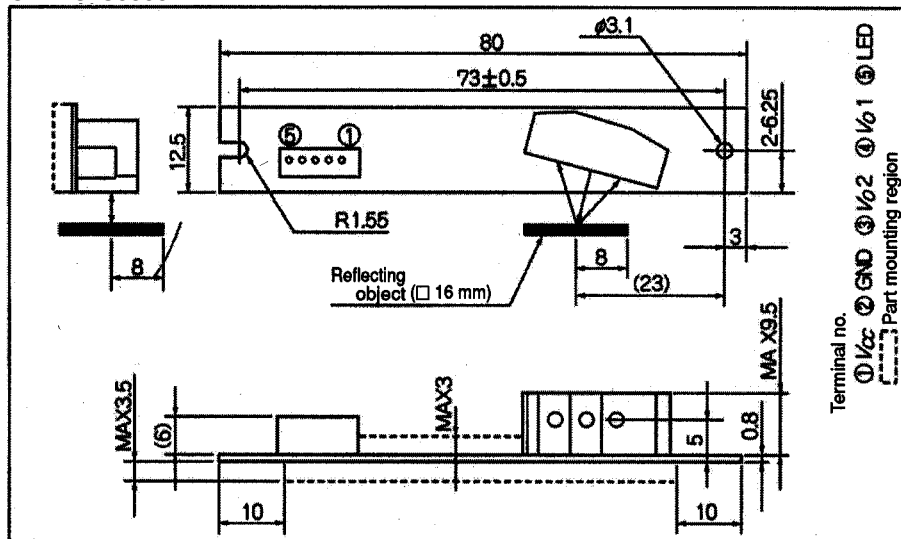

tion in the amount of reflected light for K toner density, but adequate variation in the amount of reflected light for K toner density can also be obtained with the dispersal reflecting optical system.

As described above, both color toner and K toner density on the photosensitive drum can be detected over a wider density range by using the dispersal reflecting optical system.

In color copiers and color LBP using the 4-drum (tandem) system, the 4 color toners deposited on each drum are transferred once onto a transfer belt, and then copied or printed onto paper, so density must be detected after toner has been shifted to the transfer belt.

In general, the transfer belt is black. When detecting color toner density on the transfer belt, mirror reflected light from the transfer belt surface decreases but dispersal reflected

<Fig. 12-17> Internal circuit of a color toner density sensor

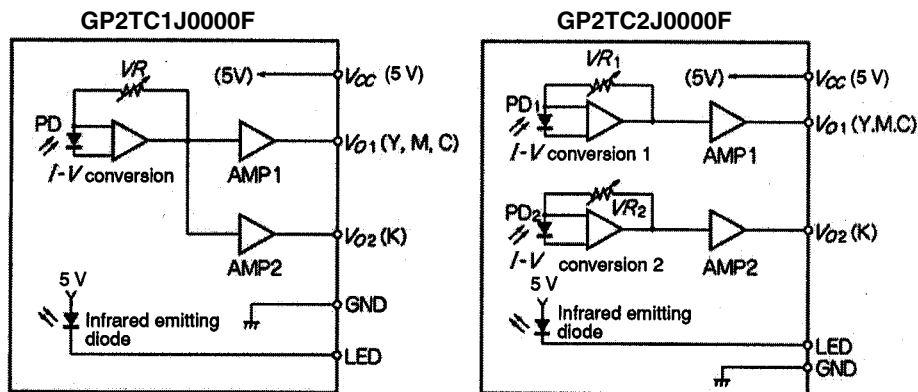

light increases as the amount (density) of toner increases — just as when detecting color toner density on a photosensitive drum.

Therefore, just as with a photosensitive drum, the dispersal reflecting optical system is best suited for detecting color toner density (Fig. 12-15). However, K (black) toner density cannot be detected on the transfer belt with the dispersal reflecting system because there is no difference in reflectance between the transfer belt (black) and K toner, but it can be detected with the mirror reflecting system.

Therefore the mirror reflecting and dispersal reflecting optical systems must be used in conjunction to detect color toner and K toner on the transfer belt.

12.4.2 Characteristics and appearance of color toner density sensors

The GP2TC1J0000F sensor employs the dispersal reflecting optical system for detecting toner density on a photosensitive drum, and uses a single photodiode (PD) as the light receiving element. The GP2TC2J0000F sensor employs both the dispersal reflecting and mirror reflecting systems to detect toner density on a transfer belt, and uses two PDs as the light receiving elements. Fig. 12-16 shows the appearance of the GP2TC1J0000F and GP2TC2J0000F and Fig. 12-17 shows their circuit diagrams.

The GP2TC1J0000F amplifies the PD output, and outputs a voltage V_{O1} corresponding to the density of the Y, M and C toner on the photosensitive drum, and a voltage V_{O2} corresponding to the K toner density. The GP2TC2J0000F amplifies the output of PD1 which receive dispersed reflected light and the of PD2 which receives mirror reflected light, and outputs the output voltages V_{O1} and V_{O2} corresponding to the density of Y, M and C toner, and the density of K toner, on the transfer belt. As an example of typical characteristics, Table 12-3 gives the characteristics of the GP2TC2J0000F. The characteristics are adjusted so they are

<Table 12-3> GP2TC2J0000F Characteristics

V₀₁: Output of terminal for color toner amount measurement
V₀₂: Output of terminal for black toner amount measurement

Parameter	Symbol	Rated value	Measurement conditions
Output voltage	<i>V₀₁</i>	TYP 1.17 V	Output when reflecting object is transfer belt ^{*1}
	<i>V₀₂</i>	TYP 2.81 V	Output when reflecting object is transfer belt ^{*1}
Output voltage variation	ΔV_{01}	TYP 1.74 V	Variation in output when reflecting object changes from transfer belt to high-density color toner ^{*1}
	ΔV_{02}	TYP 2.11 V	Variation in output when reflecting object changes from high-density black toner to transfer belt ^{*1}
Current consumption	<i>I_{cc}</i>	TYP 4 mA	When LED is unlit ^{*2}
Operating voltage	<i>V_{cc}</i>	4.5 to 5.5 V	
Operating temperature	<i>T_{opr}</i>	0 to 60°C	

*1: In actual specifications, the rule is to use a standard reflecting sample.
 *2: A current of about 20 mA must flow to the LED.

almost the TYP values in Table 12-3, using the variable resistors *VR₁* and *VR₂* in the circuit configuration diagram (Fig. 12-17).

12.4.3 Method of using color toner density sensors

The sensor is adjusted with *VR₁* and *VR₂* such that the output characteristics in response to toner density are almost fixed. However, toner density detection characteristics may vary resulting in density detection errors due to many factors: variations in the distance from the sensor to the toner deposition section (which is attributable to assembly of the equipment); variations in output characteristics due to ambient temperature fluctuations; and a drop in the intensity of light emitted by the LED due to long-term energization. In order to reduce such density detection errors, it is recommended that toner density detection be performed after the LED drive current has been adjusted to enable the sensor to maintain a stable output voltage with no toner present.

For example, if the values of the output voltages *V₀₁* and *V₀₂* in table 12-3 vary due to the above-mentioned factors, then the LED drive current should be adjusted externally so that the *V₀₁* and *V₀₂* values return to specification. After sensor output is adjusted in this way, toner density detection can be performed with the original precision.

Fig. 12-18 shows an example of a control method for externally adjusting the LED drive current. The LED drive current *I_f* is determined by the voltage *V_D* output from the D-A converter, and can be expressed with the following formula:

$$I_f = \frac{V_D - V_{BE}}{R}$$

Where, *V_{BE}* : The transistor base-emitter voltage

R : Resistance

<Fig. 12-18> Method of externally controlling LED drive current

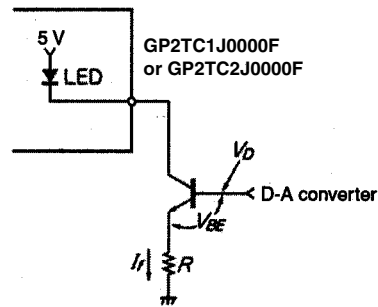

After the LED drive current has been determined as indicated above, copies and prints which properly reproduce the original colors can be obtained by calibrating the copier as follows: move a Y toner patch, M toner patch, C toner patch and K toner patch (applied under fixed conditions) sequentially in front of the sensor; read off the sensor output voltage when each toner is detected; measure toner density; and adjust drum potential. After such adjustments, when an actual copy image is written in, each of the 4 color toners will have the optimal density based on toner density measurement results.

12.4.4 Precautions for using a color toner density sensor

- (1) Because the amount of infrared emitted by an LED drops due to LED degradation, we recommend keeping the LED current normally off, and turning it on in pulses only when measuring toner density.
- (2) Use 50 mA as the maximum value for LED drive current. If 50 mA is exceeded, the LED may stop emitting light. In situations where the LED light intensity is insufficient, or when the amplifier gain must be changed (perhaps due to factors such as the color of reflectance of the photosensitive object), we can provide a custom product with different circuit constants.
- (3) The sensitivity adjustment VR on the printed circuit board is already adjusted. To prevent changes in characteristics, be careful not to touch this component during the equipment installation process etc.
- (4) If interference light enters the light detecting section, characteristics may become unsuitable. Take measures in mechanical design to prevent interference light from entering the light detector.

SPECIFICATIONS ARE SUBJECT TO CHANGE WITHOUT NOTICE.

Suggested applications (if any) are for standard use; See Important Restrictions for limitations on special applications. See Limited Warranty for SHARP's product warranty. The Limited Warranty is in lieu, and exclusive of, all other warranties, express or implied. ALL EXPRESS AND IMPLIED WARRANTIES, INCLUDING THE WARRANTIES OF MERCHANTABILITY, FITNESS FOR USE AND FITNESS FOR A PARTICULAR PURPOSE, ARE SPECIFICALLY EXCLUDED. In no event will SHARP be liable, or in any way responsible, for any incidental or consequential economic or property damage.

SHARP®

NORTH AMERICA

SHARP Microelectronics of the Americas
5700 NW Pacific Rim Blvd.
Camas, WA 98607, U.S.A.
Phone: (1) 360-834-2500
Fax: (1) 360-834-8903
www.sharpsma.com

EUROPE

SHARP Microelectronics Europe
Division of Sharp Electronics (Europe) GmbH
Sonninstrasse 3
20097 Hamburg, Germany
Phone: (49) 40-2376-2286
Fax: (49) 40-2376-2232
www.sharpsme.com

JAPAN

SHARP Corporation
Electronic Components & Devices
22-22 Nagaike-cho, Abeno-Ku
Osaka 545-8522, Japan
Phone: (81) 6-6621-1221
Fax: (81) 6117-725300/6117-725301
www.sharp-world.com

TAIWAN

SHARP Electronic Components
(Taiwan) Corporation
8F-A, No. 16, Sec. 4, Nanking E. Rd.
Taipei, Taiwan, Republic of China
Phone: (886) 2-2577-7341
Fax: (886) 2-2577-7326/2-2577-7328

SINGAPORE

SHARP Electronics (Singapore) PTE., Ltd.
438A, Alexandra Road, #05-01/02
Alexandra Technopark,
Singapore 119967
Phone: (65) 271-3566
Fax: (65) 271-3855

KOREA

SHARP Electronic Components
(Korea) Corporation
RM 501 Geosung B/D, 541
Dohwa-dong, Mapo-ku
Seoul 121-701, Korea
Phone: (82) 2-711-5813 ~ 8
Fax: (82) 2-711-5819

CHINA

SHARP Microelectronics of China
(Shanghai) Co., Ltd.
28 Xin Jin Qiao Road King Tower 16F
Pudong Shanghai, 201206 P.R. China
Phone: (86) 21-5854-7710/21-5834-6056
Fax: (86) 21-5854-4340/21-5834-6057
Head Office:
No. 360, Bashen Road,
Xin Development Bldg. 22
Waigaoqiao Free Trade Zone Shanghai
200131 P.R. China
Email: smc@china.global.sharp.co.jp

HONG KONG

SHARP-ROXY (Hong Kong) Ltd.
3rd Business Division,
17/F, Admiralty Centre, Tower 1
18 Harcourt Road, Hong Kong
Phone: (852) 28229311
Fax: (852) 28660779
www.sharp.com.hk
Shenzhen Representative Office:
Room 13B1, Tower C,
Electronics Science & Technology Building
Shen Nan Zhong Road
Shenzhen, P.R. China
Phone: (86) 755-3273731
Fax: (86) 755-3273735