

3 - Channel RGB LED Controller

DIY K191

User manual

CONTENTS

1	INTRODUCTION.....	2
2	DESCRIPTION.....	3
2.1	Common anode LED strip connection.	3
2.2	Incandescent light bulb connection.	3
2.3	LED connection.....	4
2.4	Common anode RGB LED connection.	4
2.5	Module connection to a microcontroller (Serial TTL interface).....	5
2.6	Module connection to a computer serial port.	5
2.7	Module connection to a computer USB port.....	5
2.8	Preprogrammed Sequences.	6
3	COMMANDS.....	8
3.1	Command Format.....	8
3.2	Command Description.....	8
4	WINDOWS SOFTWARE.....	10
4.1	Interface description.....	10
4.2	Module control from Microsoft Visual Basic.	12
5	KIT ASSEMBLY.	12
5.1	Parts List.....	14
5.2	PCB.....	14
5.3	Module Schematic.	15

DIY K191: 3-Channel RGB LED Controller

1 Introduction.

This kit has been designed to function as a versatile LED control module. The LED controller provides 3 high current channels to create light effects for the presentations, parties, etc. The module includes preprogrammed light sequences and can be used as a standalone LED controller. The module also supports a serial interface which uses only 2 wires to communicate with your microcontroller or PC. The simple command set allows easy module control from the microcontroller or PC.

The module is ideal for use with flexible LED light strips.

Key Features

- 3 high current channels with independent control.
- Suitable for common anode RGB LED strips, LEDs and incandescent bulbs.
- 6 preprogrammed light sequences with hard transition effects (running light, Strobe, random colors, etc...) and smooth fade effects (color change, slow on/off, etc...).
- Custom user-editable sequence.
- Wide-range effect speed adjust.
- Memory for last selected sequence and user-editable sequence.
- Serial TTL interface to control from your microcontroller or PC.
- Addressable. Multiple modules can be connected with independent control for each module.
- Windows software to control the module from PC and download the user-editable sequence.
- Small form factor (2.2" x 1.55", 56 x 39 mm).

Specifications

Operating Voltage	12VDC (nominal)
Channel Current	5A max, 12A max for all 3 channels
LED PWM frequency	480 Hz
LED intensity control	250 intensity levels/channel
Communication Interface	Serial RS232 and serial TTL interface, 9600 baud, 8 data bits, 1 stop bit, no parity, no handshaking
Dimension	2.2" x 1.55" x 0.5", 56 x 39 x 12 mm

DIY K191: 3-Channel RGB LED Controller

2 Description.

The module includes a microcontroller, 5V voltage regulator and high current MOSFETs. The microcontroller provides PWM control for the MOSFETs, the serial communication interface and includes 6 preprogrammed light effect sequences. Custom light sequences can be downloaded to the microcontroller memory. Press a button to switch the light sequences. The last selected sequence is saved in memory.

2.1 Common anode LED strip connection.

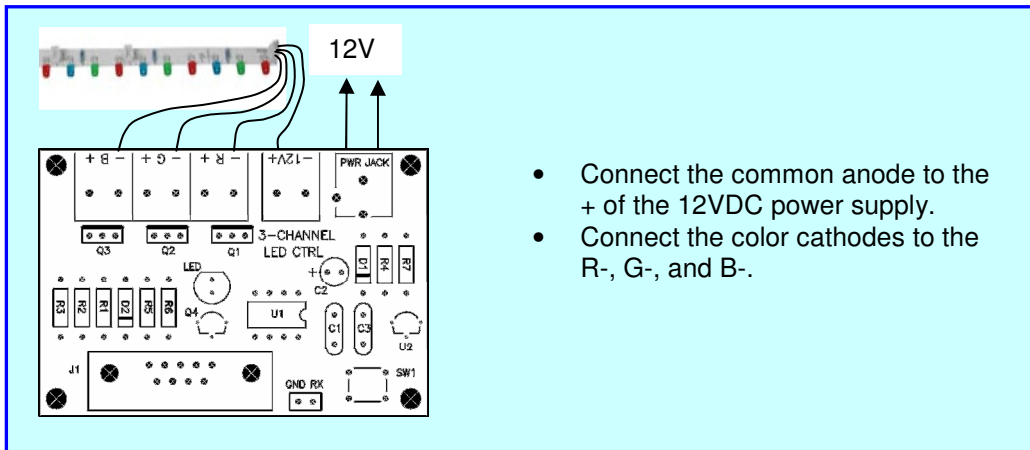

2.2 Incandescent (12V) light bulb connection.

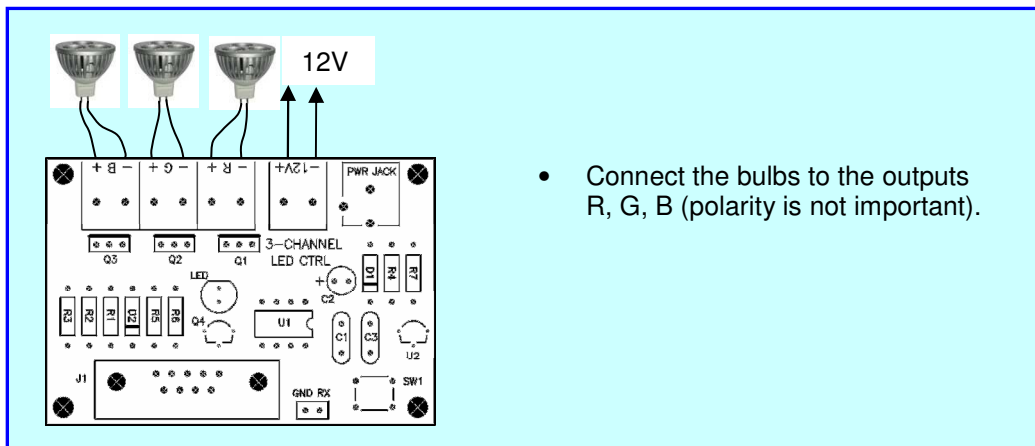

DIY K191: 3-Channel RGB LED Controller

2.3 LED connection.

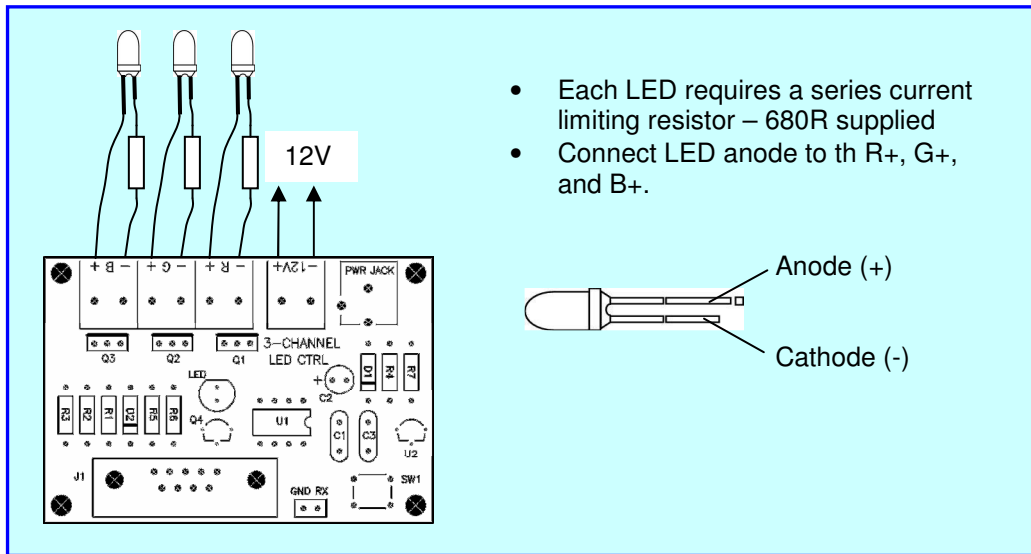

2.4 Common anode RGB LED connection.

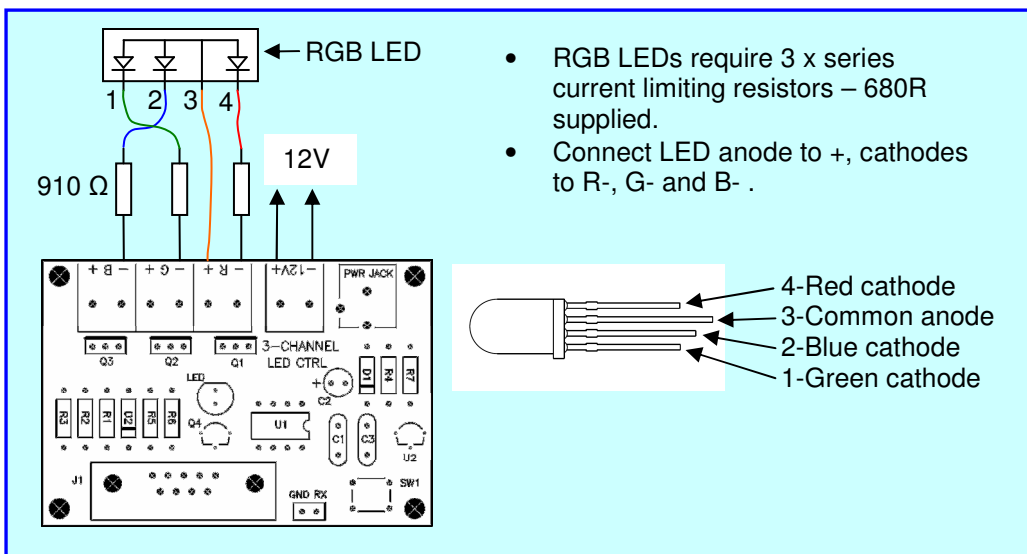

DIY K191: 3-Channel RGB LED Controller

2.5 Module connection to a microcontroller (Serial TTL interface).

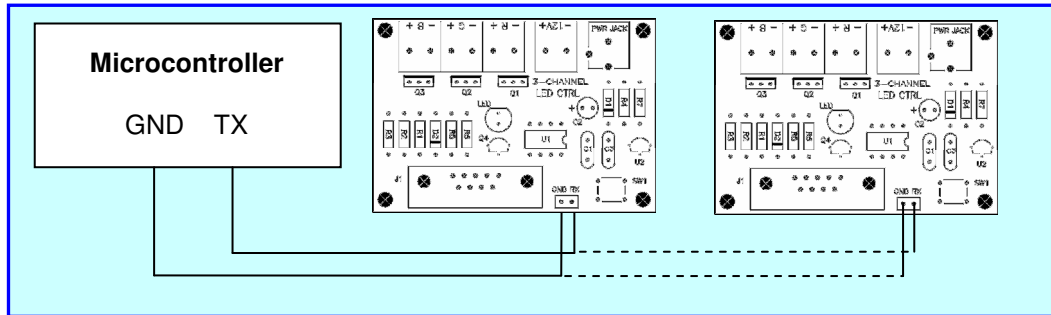

2.6 Module connection to a computer serial port.

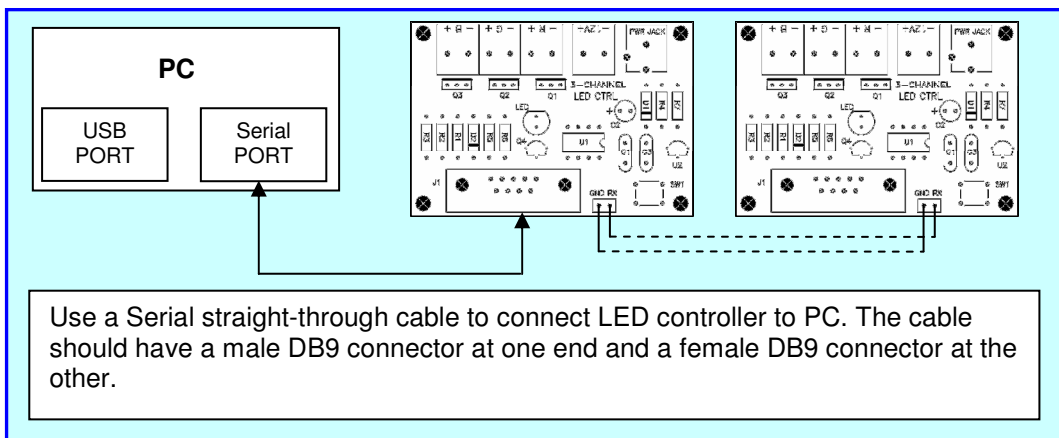

2.7 Module connection to a computer USB port.

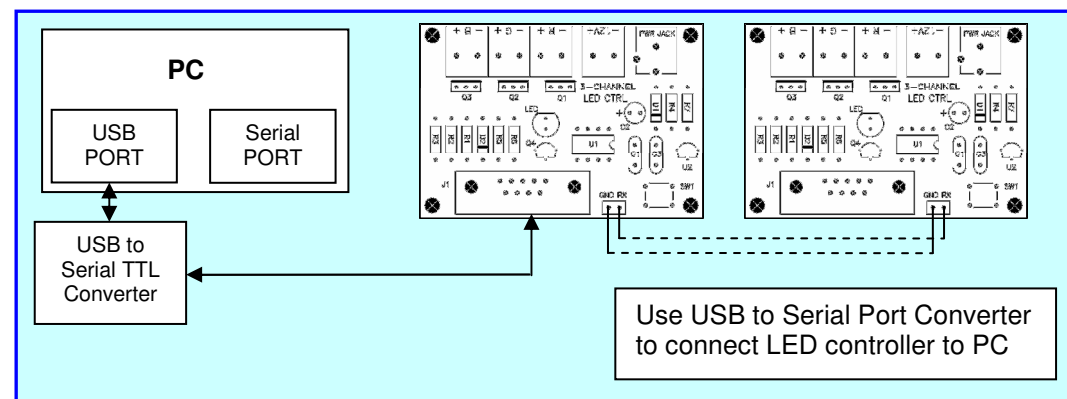

DIY K191: 3-Channel RGB LED Controller

2.8 Preprogrammed Sequences.

The module includes 6 preprogrammed light sequences with smooth fade effects and hard transition effects. Press a button to switch the light sequences. The last selected sequence is saved in memory.

Sequence 1 - the channel light intensity increases and decreases synchronously for all channels.

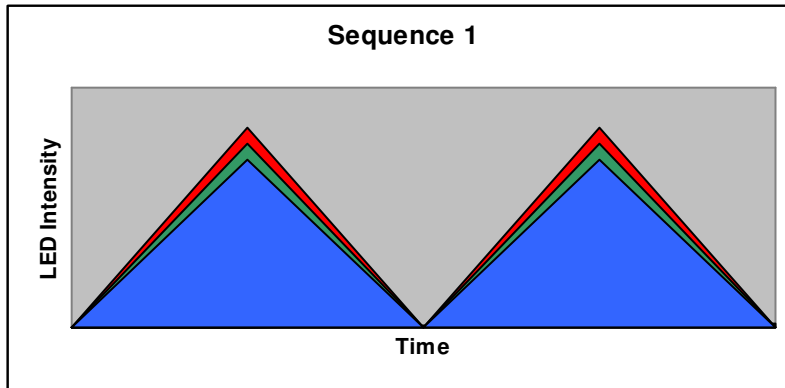

Sequence 2 - the channel 1 light intensity increases and stays at max value, next the channel 2 light intensity increases. Then the channel 3 light intensity increases.

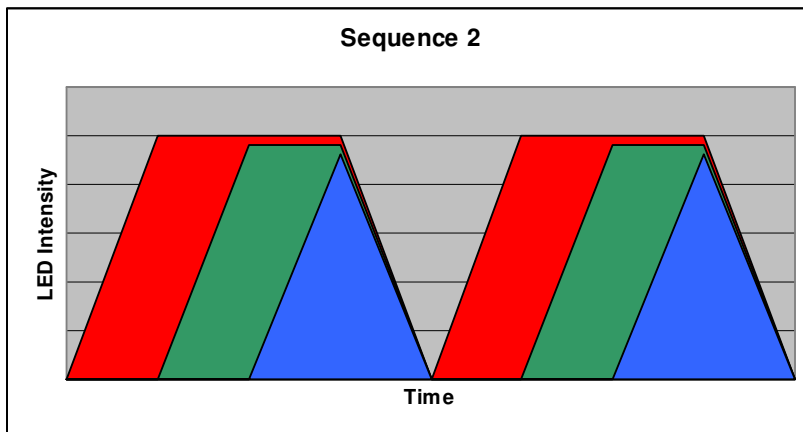

DIY K191: 3-Channel RGB LED Controller

Sequence 3 - the channel light intensity increases and decreases with the shift for each channel.

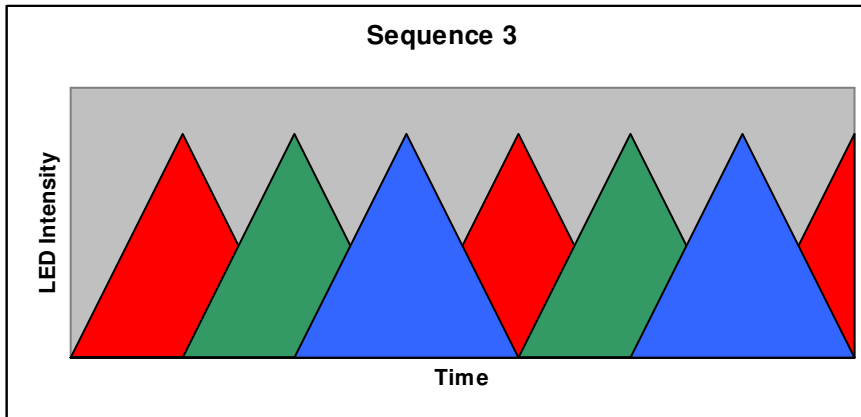

Sequence 4 – sequenced colors: red – green – blue with hard transition effects.

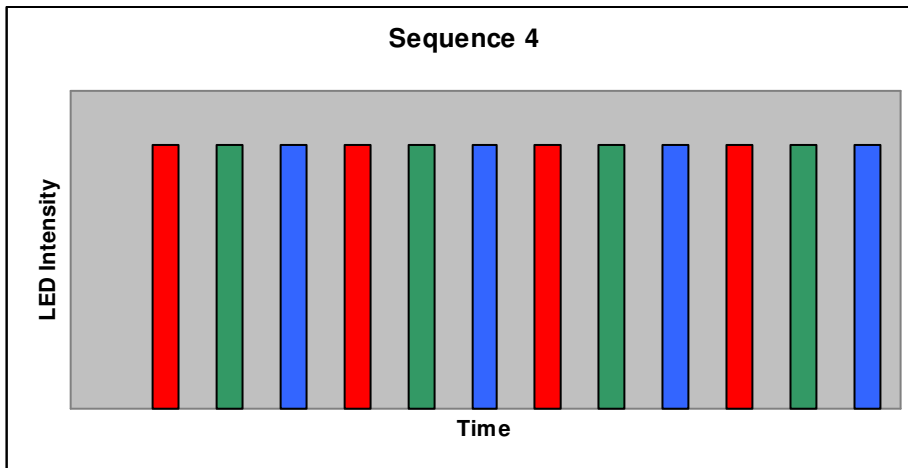

Sequence 5 – random colors with hard transition effects.

Sequence 6 – strobe effect: all outputs blink with 50% duty cycle.

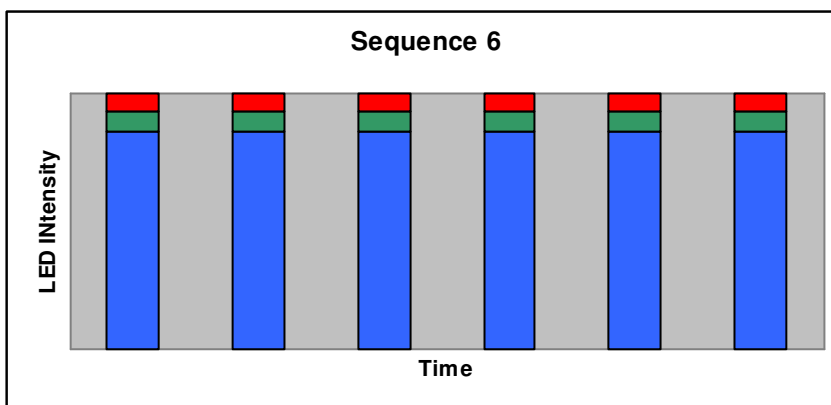

DIY K191: 3-Channel RGB LED Controller

3 Commands.

3.1 Command Format.

The module is controlled using a simple command set. The character decimal 254 (0xFE) is a command prefix. All commands start with 0xFE and a device address byte. Then a one command code byte followed by the parameters.

Command Syntax: 0xFE [device address byte] [command byte] [parameter]

Command Summary

Prefix	Command	Parameter	Description
0xFE	0x41	1 byte	Set the module address
0xFE	0x42	2 bytes	Set the channel intensity level
0xFE	0x43	1 byte	Start Sequence
0xFE	0x4C	61 bytes	Download the custom sequence
0xFE	0x52	1 byte	Set the intensity level for all channels
0xFE	0x54	1 byte	Set sequence time

3.2 Command Description.

Set the module address

Syntax hexadecimal 0xFE [device address] 0x41 [new address]

Parameter	Length	Description
[new address]	1 byte	New module address

Description: This command sets the module address. The address range is 0x4C – 0x5A. Default module address is 0x4C. The address 0x00 is a common address for all modules. The module address is stored in internal module EEPROM.

The address change requires 50 ms to take effect; therefore, the subsequent input must have an appropriate delay.

Command Example:

0xFE 0x4C 0x41 0x52 – for module with address 0x4C set the new address 0x52.

Set the channel intensity level

Syntax hexadecimal 0xFE [device address] 0x42 [channel number] [intensity level]

Parameter	Length	Description
[channel number]	1 byte	Channel number (1,2 or 3)
[intensity level]	1 byte	Intensity level (from 0 to 250)

Description: This command sets the channel intensity level.

Command Example:

0xFE 0x4C 0x42 0x02 0x82 – for module with address 0x4C set for the channel 2 the intensity level 0x82.

DIY K191: 3-Channel RGB LED Controller

Start Sequence

Syntax hexadecimal 0xFE [device address] 0x43 [sequence number]

Parameter	Length	Description
[sequence number]	1 byte	Sequence number

Description: Start the preprogrammed light sequence. The sequence range is from 1 to 7 (1 – 6 preprogrammed sequences, 7 – custom user-editable sequence).

Command Example:

0xFE 0x4C 0x43 0x04 – for module with address 0x4C start the sequence with number 0x04.

Download the custom sequence

Syntax hexadecimal 0xFE [device address] 0x4C [sequence time] [intensity data for channel 1, channel 2 and channel 3]

Parameter	Length	Description
[sequence time]	1 byte	Sequence time (from 0 to 250)
[intensity data]	60 bytes	Intensity data for the channel 1 (bytes from 1 to 20), channel 2 (bytes from 21 to 40) and channel 3 (bytes from 41 to 60)

Description: Download the custom user-editable sequence to module memory. The download process requires 100 ms to take effect; therefore, the subsequent input must have an appropriate delay.

Command Example:

0xFE 0x4C 0x4C 0x20 <data byte 1> ... <data byte 60> – for module with address 0x4C download the custom sequence with sequence time 0x20.

Set the intensity level for all channels

Syntax hexadecimal 0xFE [device address] 0x52 [intensity level]

Parameter	Length	Description
[intensity level]	1 byte	Intensity level (from 0 to 250)

Description: This command sets the intensity level for all channels.

Command Example:

0xFE 0x4C 0x52 0x82 – for module with address 0x4C set the intensity level 0x82 for all channels.

Set sequence time

Syntax hexadecimal 0xFE [device address] 0x54 [sequence time]

Parameter	Length	Description
[sequence time]	1 byte	Sequence time (from 0 to 250)

Description: Set sequence time for the current sequence.

Command Example:

0xFE 0x4C 0x54 0x40 – for module with address 0x4C set time 0x40 for the current sequence.

DIY K191: 3-Channel RGB LED Controller

4 Windows software.

The Windows software provides module control from PC and is used to create custom user-editable sequences. Use a USB to Serial Converter or Serial straight-through 9-way cable to connect the LED controller to a PC.

The Windows software can be downloaded from "www.kitsrus.com/zip/k191.zip"

If you use the USB to Serial Converter:

1. Install the Virtual Com Port Drivers. If you use the USB converter with FTDI FT232 chip the drivers are available directly from FTDI website (www.ftdichip.com). The drivers appear to the PC as an extra Com Port. Application software accesses the USB device in the same way as it would access a standard Windows Com Port. The serial data format is: one start bit, 8 data bits, and one stop bit. The baud rate is 9600 baud.
2. Connect the converter to computer USB port. To see which COM port has been assigned to module, right click on "My Computer" desktop icon and select the "Device Manager" tab. Now scroll down and open the "Ports (COM & LPT)" tab. You should see the USB serial port string with port number (Fig.1).

Fig.1

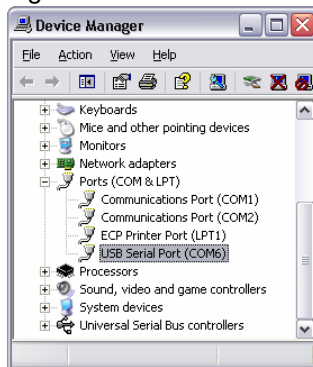

No installation required. Copy the LEDControl.exe and IniDat.ini files on your disk and double-click on LEDControl.exe to run the program.

4.1 Interface description.

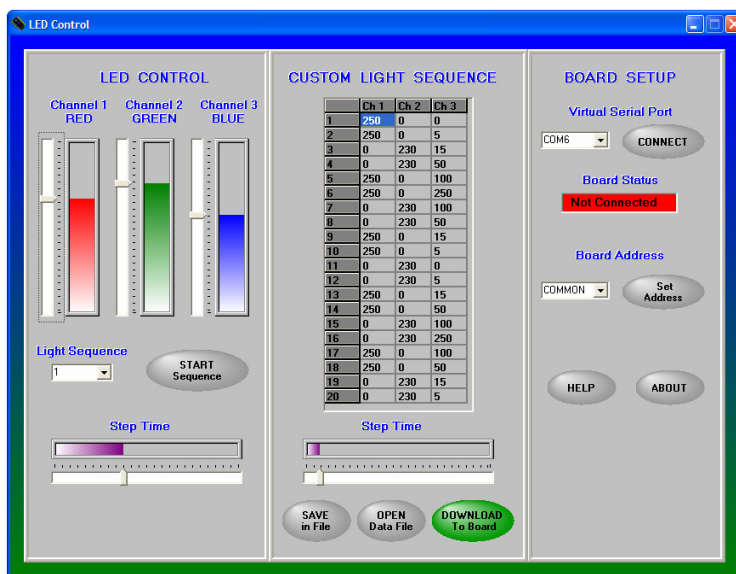

The program graphical interface includes the 3 sections:

1. LED Control
2. Custom Light Sequence
3. Board Setup

LED Control section includes the tools to set the light intensity for the each channel. When you move the slide bar the program send the commands to set the channel intensity level. Also, you can select and start the preprogrammed sequence and set sequence time.

DIY K191: 3-Channel RGB LED Controller

Custom Light Sequence section provides the tools to create the custom sequence. The section includes a table with the 3 columns. The first column includes the intensity data for the channel 1, the second column – for the channel 2 and last column – for the channel 3. The each column includes 20 points (cells) to hold channel intensity data.

To create the custom sequence enter data in cells (like in Excel Spreadsheet). Move the slide bar to set the step time between points and click “Download to Board” button. The program will send custom sequence data to board and start the custom sequence automatically.

Click “Save to file” button to save custom sequence data. The program will open the Save Dialog form. Enter the file name and click OK button to save data in file.

You can also read custom sequence data from the file. Click “Open Data File” button and select the file. The program will read data and fill the table cells automatically.

Board Setup section provides the tools to select the virtual serial port, display the board connection status and set the board address.

If you run the program first time select the Virtual Serial Port number and click CONNECT button. Check the board connection with the board status indicator.

The board address provides the opportunity to connect the multiple boards with the independent control for each board. The address range is 0x4C – 0x5A. Default module address is 0x4C. The address 0x00 is a common address for all modules. The module address is stored in internal module EEPROM.

To set the board address select the address from drop-down box and click Set Address button. The program will send a command to set the board address.

DIY K191: 3-Channel RGB LED Controller

4.2 Module control from Microsoft Visual Basic.

Visual Basic is one of the easiest languages to use for serial port communications. The mscmm32.ocx driver controls all the serial port communications and it's included with Visual Basic. The example shows how you can control the RGB module using this serial port com driver.

```
Option Explicit

Private Sub Port_Init()
    With MSComm1
        .CommPort = 2 'set the active serial port
        .Settings = "9600,N,8,1" 'set the baud rate, parity, data bits, stop bits
        .PortOpen = True 'open the serial port
    End With 'MSComm1
End Sub

Private Sub Module_Control()
    With MSComm1
        If .PortOpen = False Then
            .PortOpen = True
        End If

        ' for module wth address 0x4C set for the channel 2 the intensity level 0x82
        .Output = Chr$(&HFE) + Chr$(&H4C) + Chr$(&H02) + Chr$(&H82)
    End With 'MSComm1
End Sub
```

5 Kit Assembly.

Before starting, check the components supplied in the kit against the parts list.

It is recommended that components be soldered in following order:

1. Resistors R1 ... R7.
2. Diodes D1 and D2.

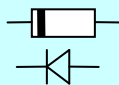

Match up the bar on the diode D1 with the diode image on the overlay.

3. Capacitors C1, C3 (polarity is not impotent).
4. U1 socket.
5. 78L05 voltage regulator.
6. Transistor Q4.
7. Capacitor C2.

C2 – Electrolytic capacitor is polarized. The positive lead is market on the overlay, the negative is marked on the body of the capacitor.

8. Tactile switch.
9. LED.
10. MOSFETs.

DIY K191: 3-Channel RGB LED Controller

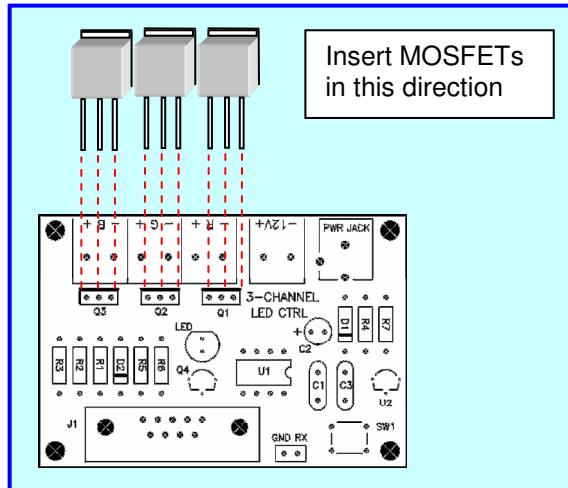

11. Power and LEDs connectors.
12. Header J2.
13. DB9 connector.

Pre-test. Do not insert the microcontroller chip into socket yet. Connect a 12VDC supply to power connector and measure the voltage across pin V and ground pin of the serial interface connector J1. If this voltage is approximately 5 volts, **remove power** and insert the microcontroller chip U1.

Three LEDs, 1 x red, 1 x green and 1 x blue, together with 3 x 680R current limiting resistors have been included with the kit. These components can be connected to the controller for testing. The microcontroller chip includes a test program that flashes each LED in turn.

First connect all the LEDs and resistors to module according to Fig 2.3. Connect the power supply and turn on – each LED will flash in turn.

- Never short the module outputs.
- Do not connect LEDs if power supply is connected to module.

DIY K191: 3-Channel RGB LED Controller

5.1 Parts List.

Ref Des	Qty	Type
Capacitors		
C1	1	0.33uF ceramic
C2	1	10uF 16V electrolytic
C3	1	0.1uF ceramic
Resistors		
R1, R2, R3, R7	4	470R 0.25W carbon film
R4, R5	2	5.1K 0.25W carbon film
R6	1	10K 0.25W carbon film
Resistors for testing	3	680R 0.25W carbon film
Semiconductors		
D1, D2	2	1N4148 diode
U1	1	CY8C24124A-24PXI MCU
U2	1	78L05, 5V regulator
Q1, Q2, Q3	3	FDU8782 n-channel MOSFET
Q4	1	2N3904 transistor
Miscellaneous		
IC socket, 8 pin	1	Socket for U1
PWR,R,G,B	4	Terminal block, 2 pin, 5.08mm step
J1	1	DB9 female connector
J2	1	Header 2 pin
PWR JACK	1	Power jack, 2.5mm central positive pin
SW1	1	Tactile switch
LED1	1	LED 5mm
LEDs for testing	3	5mm - 1 x Red, 1 x Green, 1 x Blue

5.2 PCB.

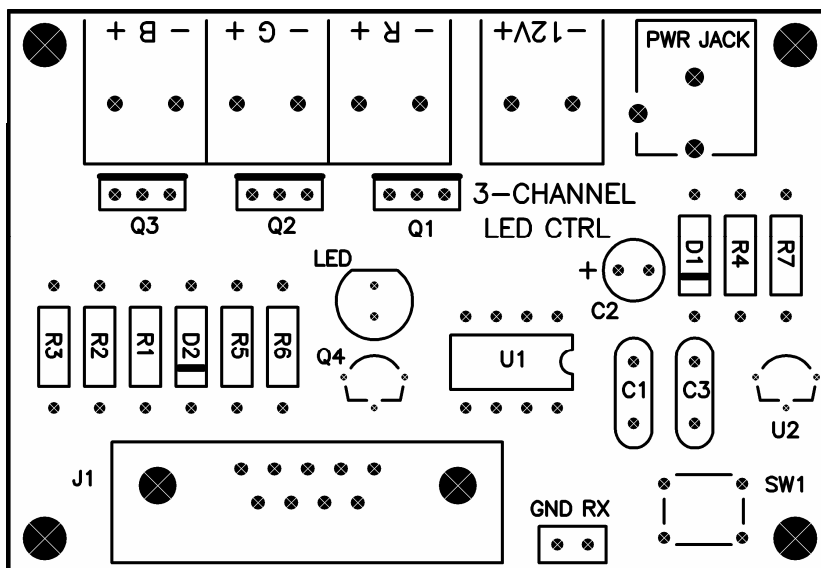

DIY K191: 3-Channel RGB LED Controller

5.3 Module Schematic.

