



CR524X-41/43/44/49

75mW Standby Power Highly Performance Current Mode PWM Switch

FEATURES

- Standby power lower than 75mW in universal AC range
- Meeting CEC6 standard
- Frequency changing and PSM Operation for Green Mode Operation
- Built-in Soft Start
- Low startup current
- Improved EMI
- Built-in Slope compensation
- Leading Edge Blanking (LEB)
- 65kHz Switching Frequency
- Over Temperature Protection(OTP)
- Audio Noise Free Operation
- OVP (Over Voltage Protection) on VDD
- OLP (Over Load Protection)
- OCP (Cycle-by-cycle Current Limiting)
- Secondary Rectifier Short Protection
- Transformer core saturation protection
- DIP-8L/SOP-8L Green package

APPLICATIONS

- Power Adapter
- Digital Cameras and Camcorder Adapter
- Set-Top Box Power
- Auxiliary Power Supply for PC and Server
- Open-frame SMPS

GENERAL DESCRIPTION

CR524X is a high Performance current mode PWM switch. Standby power is lower than 75mW at universal AC input and meet CEC6 standard. In order to reduce standby power and increase the efficiency, a multi-mode control strategy is integrated in CR524X. Three different modes are applied in the strategy and the optimization is achieved according to different loads. When load is heavy, the system works in traditional PWM (Pulse Width Modulation) mode. When the output power demands decrease, the IC enters into PFM (Pulse Frequency Modulation) mode that the frequency becomes lower with the load lighter. The proprietary pulse frequency changing block integrated in CR524X makes the frequency changes smoothly without audio noise generated. The decreased frequency can reduce the switching power consumption effectively. When the current set-point falls below a given value, the IC automatically enters into PSM (Pulse Skipping Modulation) mode that some pulse cycles are skipped to further reduce the switching power consumption. In all modes above, the IC integrates frequency jittering function for the oscillator to reduce conduction EMI emission of a power supply.

The IC also integrates constant power limiting block to achieve constant output power limit from 90VAC to 264VAC.

CR524X integrates functions and protections of Under Voltage Lockout (UVLO), VDD Over Voltage Protection (OVP), Soft Start, Over Temperature Protection (OTP), Cycle-by-cycle Current Limiting (OCP), Over Load Protection (OLP), SENSE Pin Floating Protection, GATE Clamping, leading Edge Blanking (LEB).

PIN ASSIGNMEN

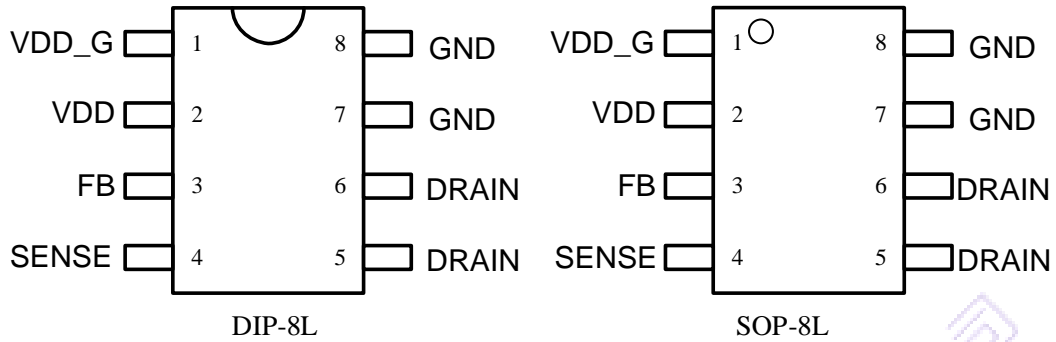

PIN DESCRIPTIONS

Pin No.	Symbol	Description
1	VDD_G	Internal Gate Driver Power Supply.
2	VDD	IC power supply pin.
3	FB	Voltage feedback pin. The PWM duty cycle is determined by this pin voltage and the current-sense signal at Pin 4.
4	SENSE	Current sense input pin.
5/6	DRAIN	HV MOSFET DRAIN Pin. The DRAIN pin is connect to the primary lead of the transformer
7/8	GND	Ground.

TYPICAL APPLICATION

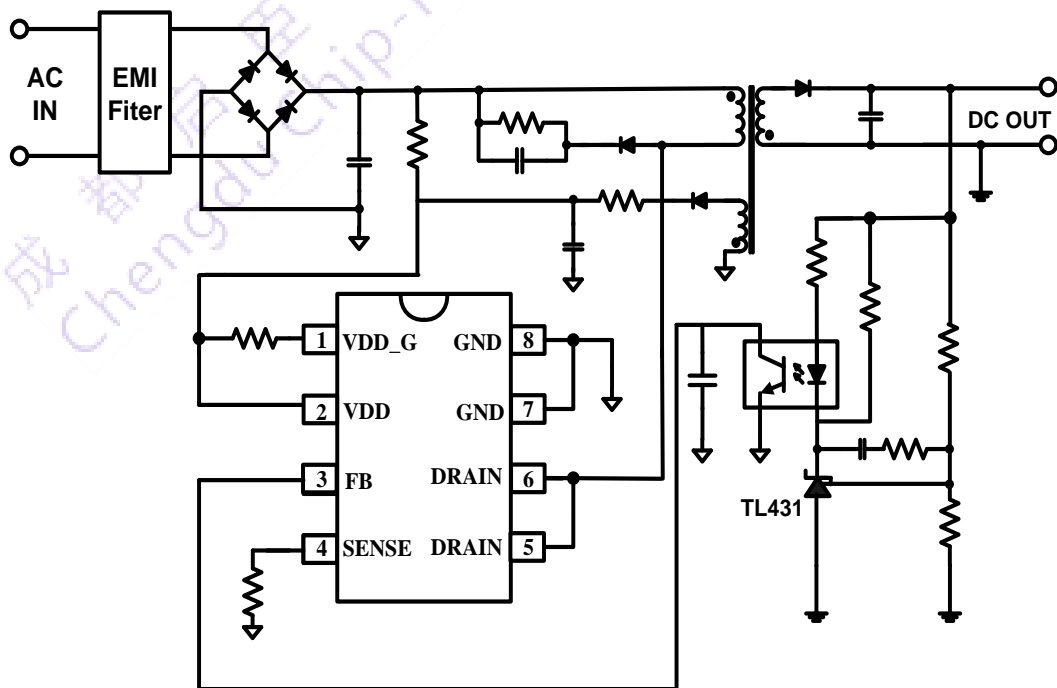

BLOCK DIAGRAM

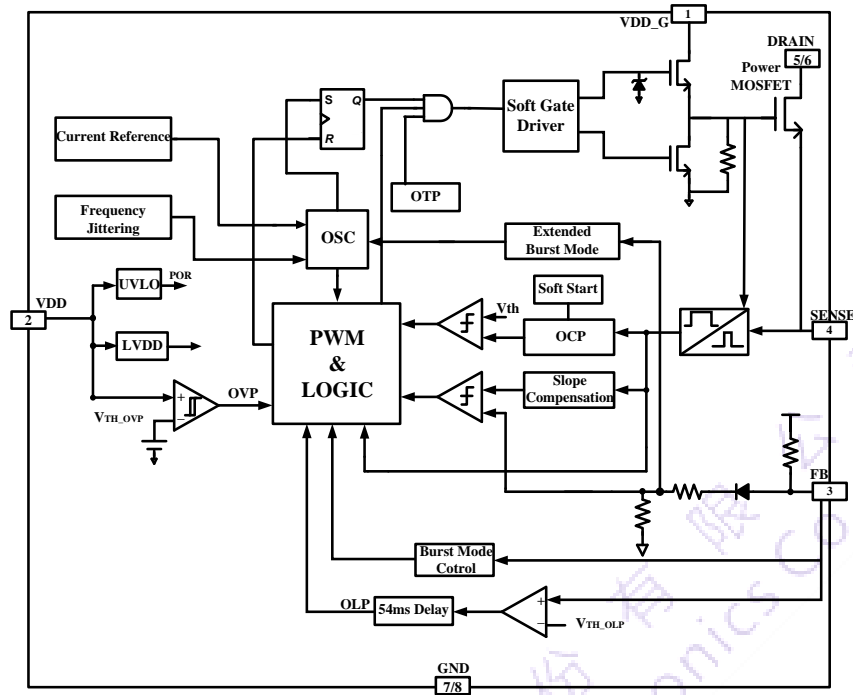

Simplified Internal Circuit Architecture

ABSOLUTE MAXIMUM PARAMETERS

Parameter	Value	Unit
DRAIN Voltage (off state)	-0.3 to BV _{dss}	V
VDD/VDD_G Voltage	-0.3 to 30	V
FB/SENSE input Voltage	-0.3 to 6	V
Min/Max Operation Junction Temperature Range	-40 to 150	°C
Min/Max Storage Temperature Range	-40 to 150	°C
Lead Temperature (Soldering, 10sec DIP-8L/SOP-8L.)	260	°C
ESD Capability, HBM (Human Body Model)	4000	V
ESD Capability, MM (Machine Model)	250	V

Note: Stresses beyond those listed under “absolute maximum ratings” may cause permanent damage to the device. Exposure to absolute maximum-rated conditions for extended periods may affect device reliability.

OUTPUT POWER TABLE

	PACKAGE	230VAC ±15%	85-265VAC
		Adapter ¹	Adapter ¹
CR5241	DIP-8L	16W	11W
CR5243	SOP-8L	8W	6W
CR5244	DIP-8L	20W	15W
CR5249	DIP-8L	27W	18W

Notes: Maximum practical continuous power in an Adapter design with sufficient drain pattern as a heat sink, when ambient temperature is 40°C.

ELECTICAL CHARACTERISTICS

 (T_A=25°C, VDD=16V, if not otherwise noted)

Symbol	Parameter	Conditions	Min	Typ	Max	Unit
Power Voltage (VDD Pin)						
I _{ST}	VDD Start up Current	VDD=15V		5	20	μA
I _{OP}	Operating Current	FB=3V		1.3		mA
UVLO _{_ON}	Turn-off Threshold Voltage		7.0	8.0	9.0	V
UVLO _{_OFF}	Turn-on Threshold Voltage		16	17	18	V
VDD _{_OVP}	VDD OVP trigger		31.5	33.5	35.5	V
VDD _{_CLAMP}	VDD Clamp Voltage		33	35	37	V
Feedback Input Section (FB Pin)						
V _{FB_OPEN}	FB Open Voltage		4.5	5.2	5.9	V
I _{FB_SHORT}	FB short current			0.35		mA
V _{TH_OD}	Zero Duty cycle FB Threshold Voltage			0.8		V
V _{TH_PL}	Power Limiting FB Threshold Voltage			3.6		V
T _{D_PL}	Power Limiting Debounce Time			54		ms
Z _{FB_IN}	Input Impedance			15.7		kohm
Current Sense Input section (SENSE Pin)						
T _{SS}	System Soft Start Time			4		ms
T _{LEB}	SENSE Input Leading Edge Blanking Time			270		ns
Z _{SENSE_IN}	Input Impedance			40		kohm
T _{D_OC}	Over Current Detection and Control Delay			100		ns
V _{TH_OC0}	Zero Duty cycle Current Limiting Threshold Voltage		0.72	0.75	0.78	V
Oscillator Section						
F _{OSC}	Normal Oscillation Frequency		60	65	70	kHz
ΔF _{OSC} /F _{OSC}	Frequency Modulation range /Base frequency		-4		4	%
ΔF _{_TEMP}	Frequency Temperature Stability			5		%
ΔF _{_VDD}	Frequency Voltage Stability			5		%
D _{MAX}	Maximum duty cycle	FB=3V, SENSE=0V	65	75	85	%
F _{_BURST}	Burst Mode Base Frequency			22		kHz

CR524X 75mW Standby Power Highly Performance Current Mode PWM Switch

MOSFET Section						
BV_{dss}	MOSFET DRAIN-SOURCE Breakdown Voltage	$V_{GS} = 0V, I_{DS} = 250\mu A$	650			V
R_{DS_ON}	Static DRAIN to Source On Resistance	$V_{GS} = 10V,$ $I_{DS} = 0.5A$	CR5241 DIP-8L		9.0	ohm
			CR5243 SOP-8L		9.0	ohm
		$V_{GS} = 10V,$ $I_{DS} = 1A$	CR5244 DIP-8L		4.5	ohm
		$V_{GS} = 10V,$ $I_{DS} = 2A$	CR5249 DIP-8L		2.2	ohm
Over temperature protection						
T_{OTP}				150		°C

OPERATION DESCRIPTION

CR524X is a low power off-line SMPS Switcher optimized for off-line flyback converter applications. Standby power is lower than 75mW at universal AC input, CR524X meets CEC6 standard. The versatile protection features and high performance make it a very competitive for min-medium power converter applications.

Startup Current and Operation Current

The typical startup current of CR524X is only about 5uA so that a high resistance startup resistor can be used to minimize power loss. For an AC/DC adapter with universal input range, a 2M Ohm startup resistor can be used to provide a fast startup and yet low power dissipation design solution.

The operating current has been reduced to 1.3mA. The low operating current enables a better efficiency and reduces the requirement of VDD hold up capacitance.

Oscillator with Frequency Jittering

It can typically operate at 65 kHz. To improve system EMI performance, CR524X integrates Frequency Jittering to operate the system with frequency jittering around setting frequency.

Cycle-by-Cycle Current Limiting and LEB

Each time the power MOSFET is switched on, a turn-on spike occurs across the sensing resistor. The spike is caused by primary side capacitance and secondary side rectifier reverse recovery. To avoid premature termination of the switching pulse, an internal leading edge blanking circuit is built in. During this blanking period (270ns, typical), the PWM comparator is disabled and cannot switch off the gate driver. The PWM duty cycle is determined by FB pin voltage and the current-sense signal at Pin 4.

Built-in Slope Compensation

In the conventional application, the problem of the stability is a critical issue for current mode controlling, when it operates in higher than 50% of the duty-cycle. In CR524X, the slope compensation circuit is integrated by adding voltage ramp onto the current sense input voltage for PWM generation. This greatly improves the close loop stability at CCM and prevents the subharmonic oscillation and thus reduces the output ripple voltage.

Constant Power Limiting

In flyback converter applications, the GATE drive delay can cause system OPP (Over Power Point) to change according to the AC line input voltage. In CR524X, a Constant Power Limiting block is integrated to achieve constant maximum output power capability over universal AC input range.

Soft Start

CR524X features an internal 4ms (typical) soft start that slowly increases the threshold of cycle-by-cycle current limit comparator during startup sequence. It helps to prevent transformer saturation and reduce the stress on the secondary diode during startup. Every restart attempt is

followed by a soft start activation.

Secondary rectifier short protection and Transformer core saturation protection

If switching power supply controller works in Secondary rectifier short state or transformer core saturation state over a long time, the switching power supply controller may work abnormally. The CR523X integrates Secondary rectifier short protection and Transformer core saturation protection to solve the problems. When CR524X detect secondary rectifier short state or transformer core saturation state, then cut off the output of PWM. The voltage of VDD decreases under UVLO_ON.

Green Mode Operation

Since the main power dissipation at light or zero load in a switching mode power supply is from the switching loss which is proportional to the PWM switching frequency. To fulfill green mode requirement, it is necessary to reduce the switching cycles under such conditions either by skipping some switching pulses or by reducing the switching frequency.

Gate Drive

The output stage of CR524X is a fast totem-pole gate driver. Cross conduction has been avoided to minimize heat dissipation, increase efficiency, and enhance reliability. An internal clamp is added for MOSFET gate protection at higher than expected VDD input. A soft driving waveform is implemented to minimize EMI.

In addition to the gate drive control scheme mentioned, the gate drive strength can also be adjusted externally by a resistor connected between VDD and VDD_G, the falling edge of the DRAIN output can be well controlled. It provides great flexibility system EMI design.

Protection Control

Good power supply system reliability is achieved with its rich protection features including Cycle-by-Cycle current limiting (OCP), Over Load Protection (OLP), VDD over voltage protection, over temperature protection (OTP), feedback loop open protection, SENSE Pin Floating Protection, short circuit protection and Under Voltage Lockout on VDD (UVLO).

CHARACTERIZATION PLOTS

($T_A=25^{\circ}\text{C}$, $V_{DD}=16\text{V}$, if not otherwise noted)

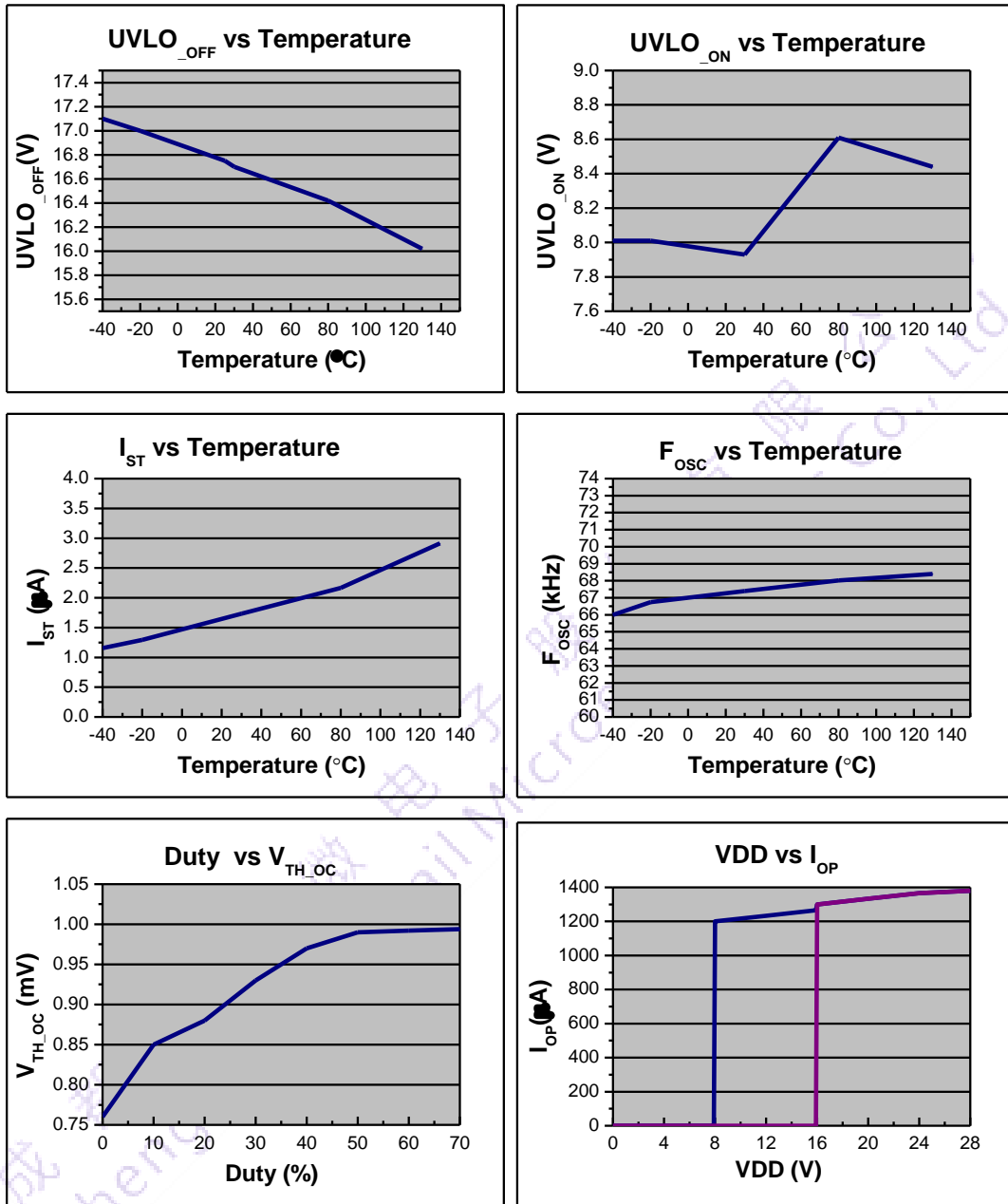

PACKAGE OUTLINE DIMENSIONS

DIP-8L

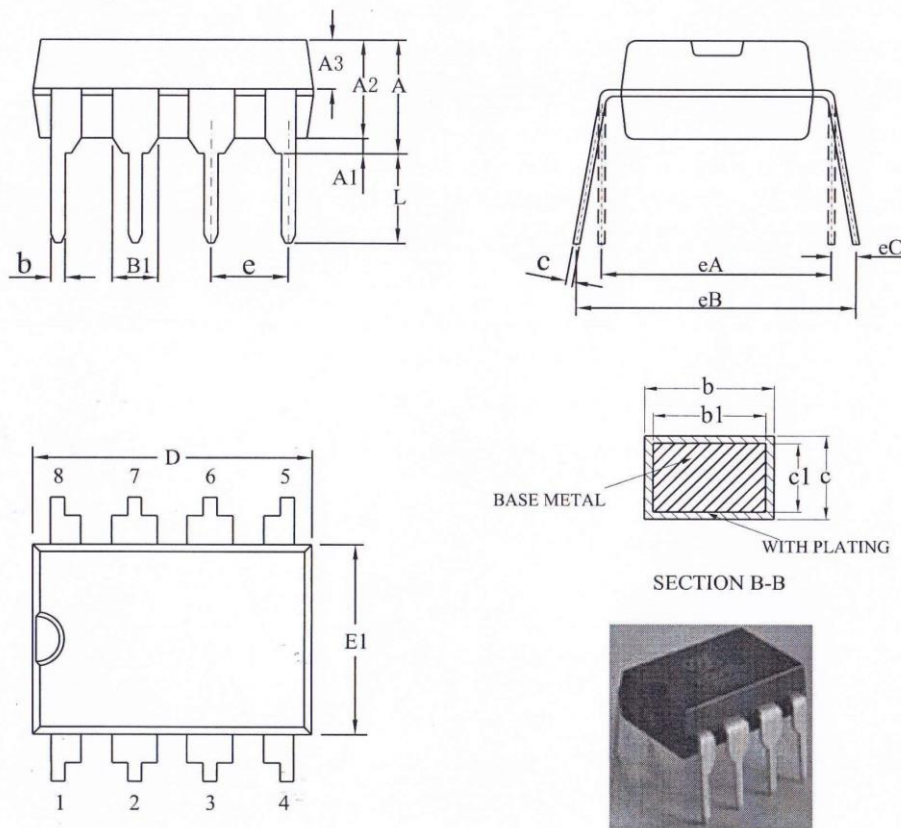

Symbol	Millimeter		
	Min	Nom	Max
A	3.60	3.80	4.00
A1	0.51	-	-
A2	3.20	3.30	3.40
A3	1.55	1.60	1.65
b	0.44	-	0.52
b1	0.43	0.46	0.49
B1	1.52REF		
c	0.25	-	0.29
c1	0.24	0.25	0.26
D	9.15	9.25	9.35
E1	6.25	6.35	6.45
e	2.54BSC		
eA	7.62REF		
eB	7.62	-	9.30
eC	0	-	0.84
L	3.00	-	-

PACKAGE OUTLINE DIMENSIONS

SOP-8L

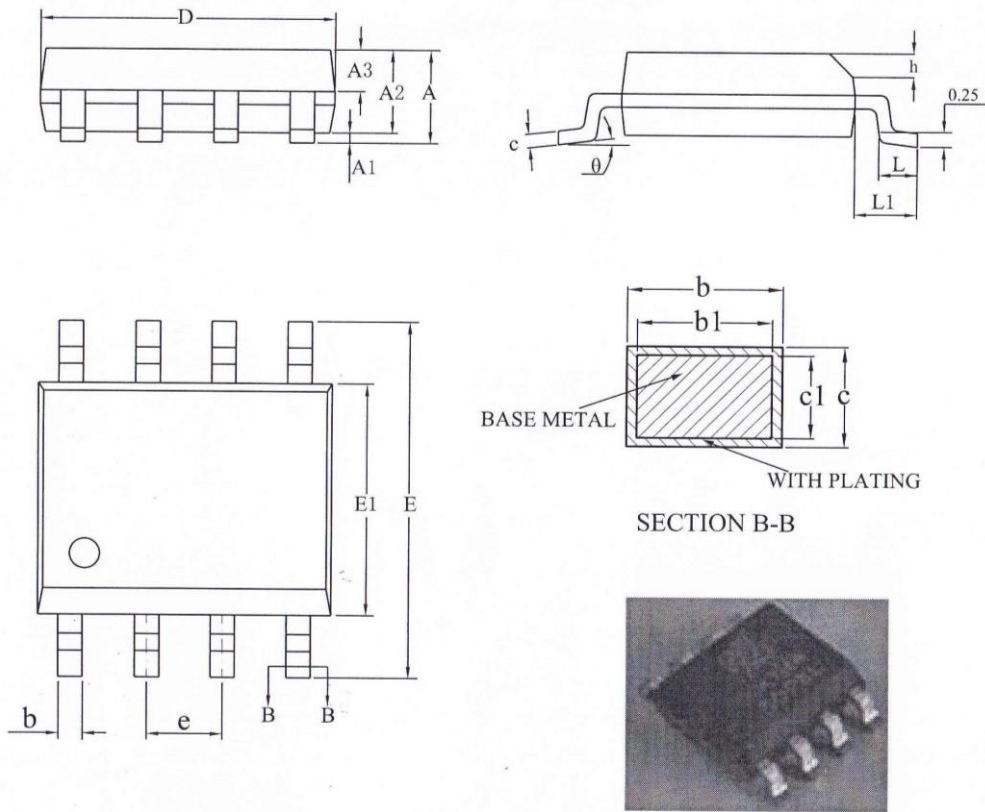

Symbol	Millimeter		
	Min	Nom	Max
A	-	-	1.75
A1	0.10	-	0.225
A2	1.30	1.40	1.50
A3	0.60	0.65	0.70
b	0.39	-	0.47
b1	0.38	0.41	0.44
c	0.20	-	0.24
c1	0.19	0.20	0.21
D	4.80	4.90	5.00
E	5.80	6.00	6.20
E1	3.80	3.90	4.00
e	1.27BSC		
h	0.25	-	0.50
L	0.50	-	0.80
L1	1.05REF		
θ°	0°	-	8°

PRINTING INFORMATION

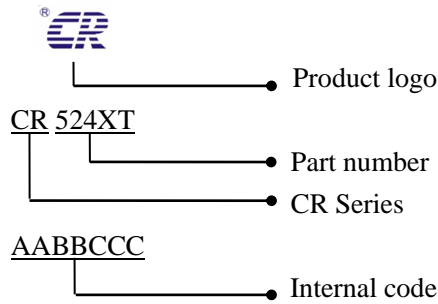

ORDERING INFORMATION

Part number	package	Packaging Material	One plate	One box	One case
CR524X	DIP-8L	Tube	50	2000	20000

The minimum order quantity of DIP-8L product is 2,000,the quantity of one box.

PRINTING INFORMATION

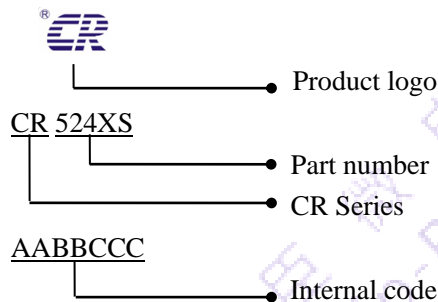

ORDERING INFORMATION

Part number	package	Packaging Material	One plate	One box	One case
CR524X	SOP-8L	Tape and Rell	2500		20000/50000

The minimum order quantity of SOP-8L product is 20,000/50,000,the quantity of one box.

Product storage conditions

Item	Value
Storage temperature	0-40℃
Storage humidity	30-70%RH

CR524X 75mW Standby Power Highly Performance Current Mode PWM Switch

MSL (SOP-8L)	3
--------------	---

Important statement

Chip-Rail reserves the right to make changes without further notice to any products herein. Customers shall obtain the latest information of the products and check whether it is complete and the latest version before placing an order. If any use limits are exceeded, device functionality should not be assumed, damage may occur and reliability may be affected. Buyer is responsible for its products design and applications using Chip-Rail products, comply with safety standards and take safety measures to protect personal and property safety.

成都启臣微电子股份有限公司
Chengdu Chip-Rail Microelectronics Co., Ltd.