

MOBICON

Electronic Components

PRODUCT SPECIFICATION

MEC QUARTZ CRYSTAL

FREQUENCY COMPONENTS

AT39 Series QUARTZ CRYSTAL SPECIFICATION

MOBICON HOLDINGS LTD.		
Prepared By	Sign.	Approved By
Leo Wong		C.H. Wong

www.mobicon.com

MIEC

SPECIFICATION OF CRYSTAL UNIT

PART NO. :

AT39-3.579545M1630F

ELECTRICAL CHARACTERISTICS

1. Nominal Frequency	3.579545 MHz
2. Holder Type	AT39
3. Frequency Tolerance	± 30 ppm
4. Equivalent Resistance	150 Ohm max.
5. Insulation Resistance	500M Ohm @100V _{DC}
6. Temperature Tolerance	+/- 50 ppm at -10 ~ +60°C
7. Operating Temperature Range	-10 ~ +60°C
8. Storage Temperature Range	-10 ~ +70°C
9. Loading Capacitance	16 pF
10. Drive Level	100uW max.
11. Aging	± 5 ppm/ year max.
12. Oscillation Mode	Fundamental

DIMENSIONS (mm)

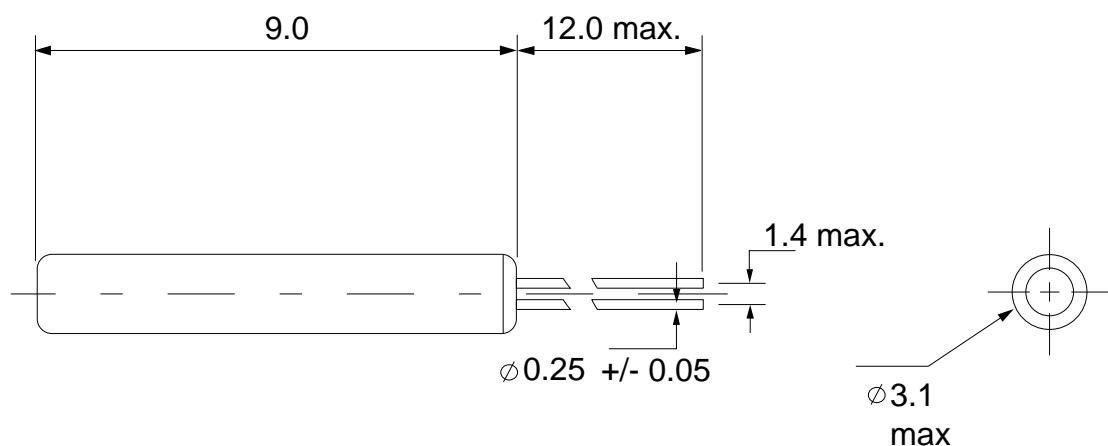

Prepared By: Leo Wong

DOC. No: AT39-3.579545MHz16pF30ppmF