

深圳市鸿泰机电科技有限公司

APPROVAL SHEET

型号 Model NO.: AC15050 220V 150*150*50mm Ball bearing Wire: 20AWG.....



1. Scope of application:						
This product specification specifies the product performance and test methods as the basis for technical confirmation						
2. General characteristic:						
2.1 Product application scope						
This product is mainly used for ventilation and heat dissipation of automatic equipment such as ground automatic control device, electronic equipment, medical equipment, computer, power supply equipment, electric welding machine, packaging and printing equipment, satellite communication, numerical control machinery and so on.						
2.2 Standard test conditions:						
Generally, the test shall be conducted under the conditions of standard atmospheric pressure, temperature of 5 ~ 35 °C and relative humidity of less than 85%; The relative humidity in the specification is less than 25 °C , and the relative humidity in this standard is less than 60%						
2.3 Basis standard						
GB12350-2009 Safety requirements for small power motors						
CNCA-01C-013: 2007 implementation rules for compulsory certification of electrical and electronic products (small power motor)						
3. Product structure						
The product is composed of cylindrical aluminum alloy outer frame, PBT plastic fan blade and motor. It is installed through double-sided flange, with the characteristics of small volume, maintenance free and convenient installation. It also has the excellent performance of low noise, low vibration and reliable operation.						

4. General characteristics

No.	Item	Standard value	Unit	Remark
1	Product model	15050HBL		
2	Outline Dimension	150*150*50	mm	
3	Rated Voltage	AC 220	V	
4	Starting Voltage	AC 187	V	
5	Frequency	50	Hz	
6	Rated current	0.27	A	
7	Power	35	W	
8	Speed	2700	RPM	
9	Airflow AT ZERO STATIC PRESSURE	5.0	m ³ /min	
10	Wind speed		m/s	
11	Temperature rise	58	°C	
12	Noise value	55	dB(A)	
13	CONNECTOR	UL1007#20AWG	mm	
14	Use environment	-20~+60	°C	
15	Unit weight	0.8	KG	
16	Packing	24	PCS	
17	Lifetime	50000h		

Specifications of main materials

No.	Part name	Material	Safety regulation level	Safety code	Material manufacturer
1	Outer frame	ADC12			
2	Fan blade	PBT-PV33%			
3	Stator and rotor	1300			
4	Copper wire	QA-1			
5	Bearing	Ball bearing			

MATERIAL

- 1. FRAME: ALuminum die-cast, Black color
- 2. IMPELLER: THERMOLASTIC PBT OF UL 94V0
- 3. LEAD WIRE: UL 1007# 18 AWG

DIMENSIONS: MM

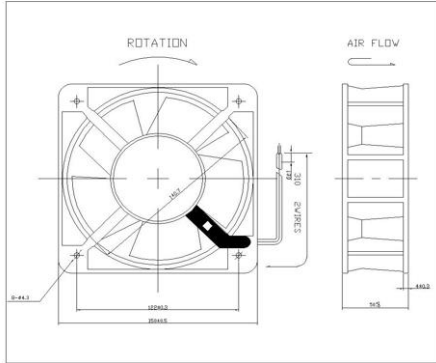

SPEC. NO		REVISE DATE	
ISSUE DATE		EDITION	
PAGE			

