

# SPECIFICATION FOR APPROVAL

## 承 认 书

Description : Integrated Buzzer

Vender's Part No. : QSI-2910

Customer's Name. : \_\_\_\_\_

Serial No. : \_\_\_\_\_

Version No. : \_\_\_\_\_

CUSTOMER'S APPROVED SIGNATURE		

兴化市华兴机电有限公司

Approved By	Checked By	Made By

联系人: 王勇明

TEL: 18261465396

## A. SCOPE

This specification applies Integrated buzzer, **QSI-2910**

## B. SPECIFICATION

No.	Item	Unit	Specification	Condition
1	Oscillation Frequency	KHz	3.5±0.5	
2	Operating Voltage	V <sub>DC</sub>	3~24	
3	Rated Voltage	V <sub>DC</sub>	12	
4	Current Consumption	mA	MAX.12	at Rated Voltage
5	Sound Pressure Level	dB	MIN. 95	at 10cm at Rated Voltage
6	Tone Nature		Constant	
7	Operating Temperature	°C	-20~ +60	
8	Storage Temperature	°C	-30~ +70	
9	Dimension	mm	Φ30.0 x H24	See appearance drawing
10	Weight (MAX)	gram	8	
11	Housing Material		PPO( Black)	
12	Leading Pin		Triode	
13	Environmental Protection Regulation		\	

## C. APPEARANCE DRAWING

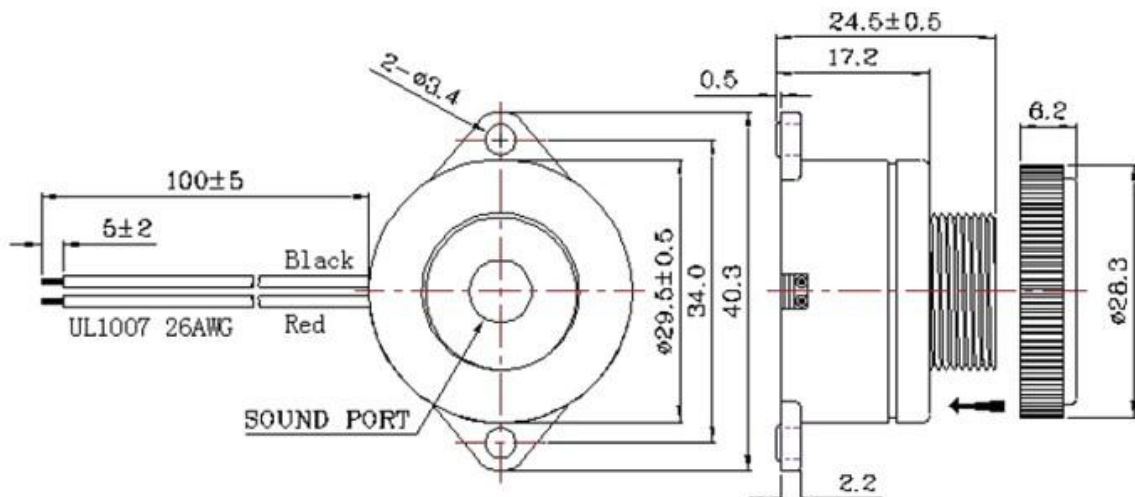

Tol: ± 0.5

Unit: mm

## D. Profile Picture:



## E. Typical Frequency Response Curve

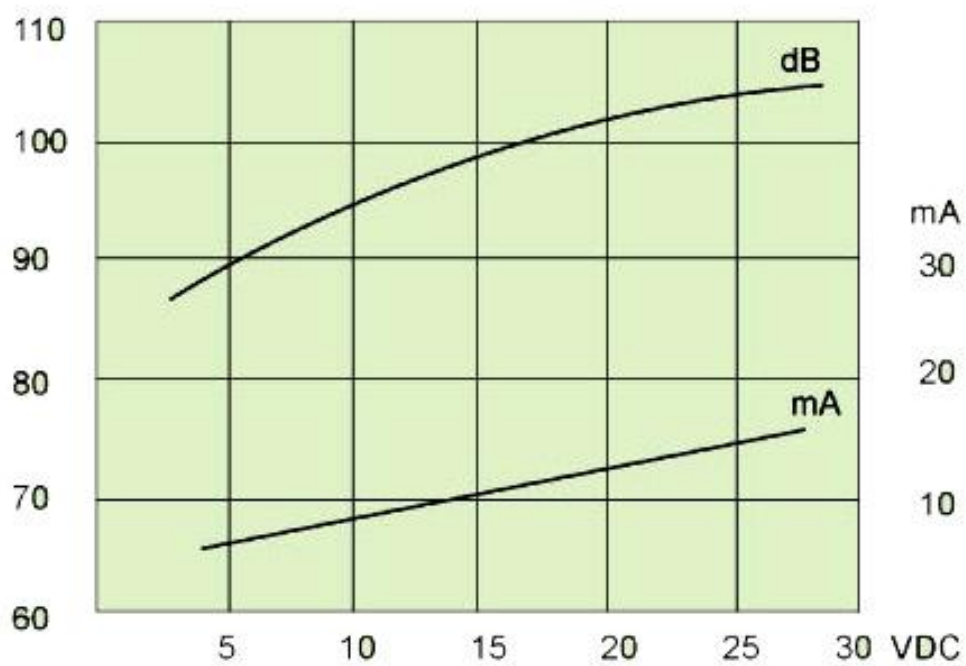

## REMARKS.

可波峰焊，工作时间 $\geq 1S$ ；焊接温度 $\leq 280^{\circ}C$ ；焊接时间 $\leq 3S$