

Hybrid integrated IGBT driver



Patent protection



RoHS



FEATURES

- Built-in isolated DC-DC power supply; Single power supply drive topology
- High isolation voltage of 3750VAC
- Input signal frequency up to 20kHz
- Built-in fault circuit with a pin for fault feedback
- Drive signal ignored during blocking time, fault circuit reset after blocking time end
- Adjustable controlled time of fault detection circuit
- Adjustable protective soft cut-off time
- SIP package
- EN60950 safety approval

Matched IGBT

- 600V series IGBT (current $\leq 600A$)
- 1,200V series IGBT (current $\leq 400A$)
- 1,700V series IGBT (current $\leq 200A$)

Applications

- Universal inverter
- AC servo drive system
- UPS systems (Uninterruptible Power Supply)
- Electric welding machine

QP12W08S-37 is an integrated hybrid IGBT driver designed with a built-in isolation DC-DC converter. This device is a fully isolated gate drive circuit consisting of an optimally isolated gate drive amplifier and an isolated DC-DC converter. The gate driver provides a fault protection function based on desaturation detection and fault output.

Selection Guide

Certification	Part No.	Input Voltage (VDC)	Output		Max. Driving Current (A)
			Output High-level Voltage V_{OH} (VDC)	Output Low-level Voltage V_{OL} (VDC)	
CE	QP12W08S-37	15	15	-9	± 8

Maximum ratings

Item	Symbol	Testing Conditions*	Value	Unit
Power Supply Input Voltage	V_D		16	V
Input Impulse High-level Current	I_{IH}		25	mA
Driver Output Peak Current	$I_{g\ on}$		+8	A
	$I_{g\ off}$		-8	
Fault Output Current	I_{fo}		20	mA
Max. Input Voltage to Fault Detect Pin	V_{R1}		50	V

Input Specifications

Item	Symbol	Testing Conditions	Min.	Typ.	Max.	Unit	
Power Supply	Input Voltage	V_D	14.5	15	15.5	V	
	Input Current	I_{in}	$V_D = 15V, f = 20kHz, D = 0.5, Q = 0\mu C$	--	46	--	mA
			$V_D = 15V, f = 20kHz, D = 0.5, Q = 3.0\mu C$	--	165	--	
Input Impulse	High-level Voltage	V_I	3.7	--	5.7	V	
	High-level Current	I_{IH}	10	--	20	mA	

Note: D is the input impulse duty cycle.

Output Specifications

Item	Symbol	Testing Conditions	Min.	Typ.	Max.	Unit	
Isolated Power Supply Voltage	V_{CC}	$V_D = 15V, f = 20kHz, D = 0.5$	14.5	16.0	18	V	
	V_{EE}	$V_D = 15V, f = 20kHz, D = 0.5$	-7	-8.5	-10		
Drive Output	High-level Voltage	V_{OH}	$V_D = 15V, f = 20kHz, D = 0.5, Q = 3.0\mu C$	14.5	15.0	--	V
	Low-level Voltage	V_{OL}	$V_D = 15V, f = 20kHz, D = 0.5, Q = 3.0\mu C$	-7	-9	--	
	Rise Time	t_r		--	0.3	1	μS
	Fall Time	t_f		--	0.3	1	
	Total Charge	Q	$V_D = 15V, f = 20kHz, D = 0.5$	--	--	3.0	

General Specifications

Item	Symbol	Testing Conditions	Min.	Typ.	Max.	Unit
Operating Frequency	f		--	--	20	kHz
Input Impulse and Drive Output	Rise Delay Time	t_{PHL}	--	0.5	1.2	μS
	Fall Delay Time	t_{PHL}	--	1	1.2	
Controlled Time of Detect Fault Circuit	t_{trip}	$V_D = 15V$, fault protection function	--	3.5	4.0	μS
Fault Soft Turn-off Time	t_{cf}	$V_D = 15V$, fault protection function	--	4.5	7	
Fault Reset Time	t_{timer}	$V_D = 15V$, fault protection function	1	1.4	2	mS
Fault Threshold Voltage	V_{ocp}	$V_D = 15V$	--	9.5	--	V
Fault Output Terminal Voltage	V_{fo}	$V_D = 15V$, fault protection function	--	-8.0	--	
Insulation Test	V_{iso}	Sine wave 50Hz/60 Hz, 1min	--	--	3750	VAC
Operating Temperature	T_{op}		-40	--	+71	$^{\circ}C$
Storage Temperature	T_{st}		-50	--	+125	
Weight	W		--	6.7	--	g
Safety Standard			EN60950			
Safety Certification			EN60950			
Safety Class			CLASS III			

Design Reference

1. Description of Characteristic

1) Definition of Fault-free Characteristic

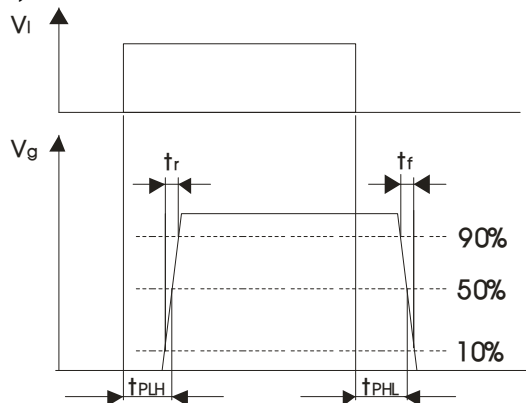

2) Definition of Fault Characteristic

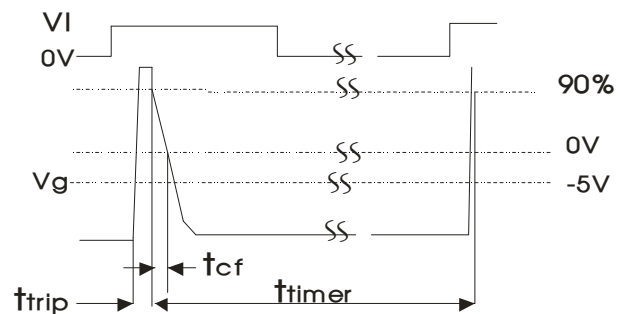

2. Typical application

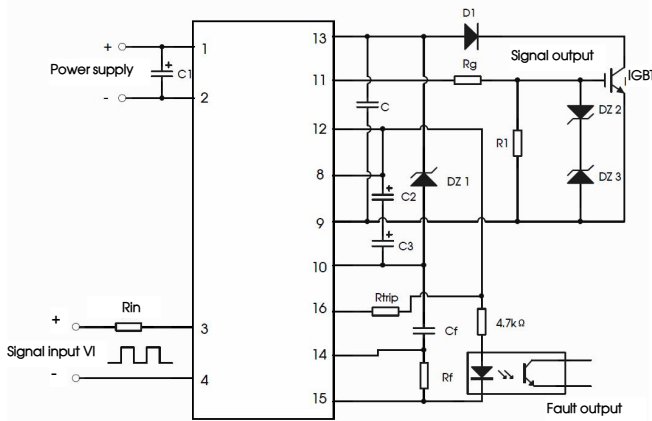

C1	100μF
C2	100μF
C3	100μF
Rtrip	set as required (optional)
Cf	set as required (optional)
Rf	set as required (optional)
Rg	5 Ω
R1	10k Ω
DZ1	TVS (30V, 0.5W)
DZ2, DZ3	TVS (18V, 1W)
D1	fast recovery diode (trr ≤0.2μs)

Note:

1. For further ripple & noise reduction, connect an additional capacitor each with a value between 1μF and 10μF in parallel with capacitors C2 and C3.
2. If the input impulse voltage is too high, the current-limiting resistance can be adjusted to meet the requirements of the input impulse current. A high-speed opto-coupler LED with a 200Ω series resistance is connected in between the signal input terminals and the current-limiting resistance can be calculated according to the following formula:

$$R_m = \frac{V_I - 1.7V}{I_{IH}} - 200\Omega$$

3. For harsh applications in environments with long wires, we recommend adding an additional capacitor C at a distance between 9 feet and 13 feet from the unit as appropriate.

(1) Fault soft turn-off time adjustment:

When a short-circuit or an over-current condition occurs, the driver protection circuit activates and slowly turns off the IGBT. The default turn-off time is 4.5μs, and this turn-off time can be adjusted by connecting an external resistor Rf to reduce the time, or capacitor Cf to increase the time. The adjustment range is 2.5μs to 10μs. The values for protective turn-off time adjustment in the table below are for reference only and must be verified to suite the actual application.

Rf (KΩ)	t _{cf} (μS)	Cf (nF)	t _{cf} (μS)
—	4.5	—	4.5
1.5	4.0	1	4.9
0.5	3.5	3.3	5.3
0.3	3.0	10	6.5
0.11	2.5	22	9.3

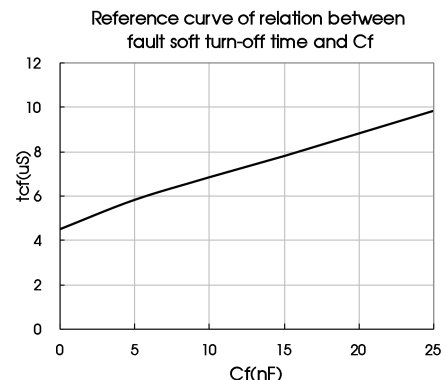
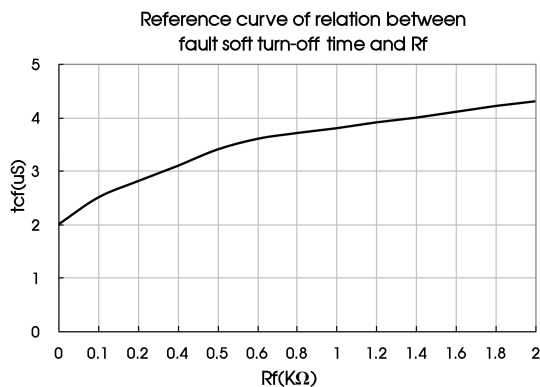

Note: V_D = 15V

(2) Controlled fault detection time adjustment:

When a short circuit or an over current condition occurs, the time from the moment the driver detects a short circuit or an over current condition to when the gate potential drops to 90% of the normal amplitude is called "Controlled Time of Fault Detection". The driver sets the default maximum controlled time for the fault detection circuit and the user can reduce this time, by connecting an external Rtrip resistor. The minimum time that can be adjusted is 1.6μs. The values for adjustment controlled short circuit time detection in the table below are for reference only and must be verified to suite the actual application

Reference values for Controlled fault detection time adjustment	
R _{trip} (kΩ)	T _{trip} (μS)
--	3.50
68	3.00
51	2.80
30	2.48
20	2.28
15	2.0
10	1.9
5.1	1.60

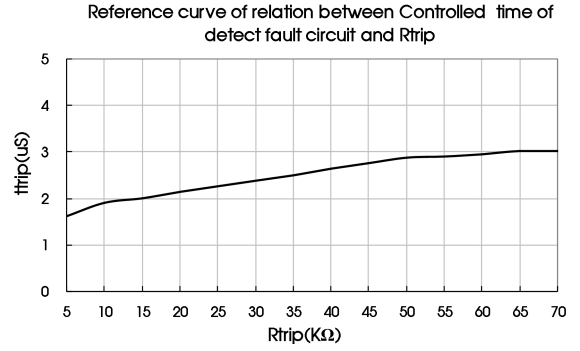

Note: V_D=15V.

3. For additional information please refer to IGBT Driver application notes on www.mornsun-power.com

Dimensions and Recommended Layout

THIRD ANGLE PROJECTION

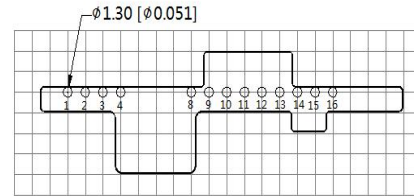
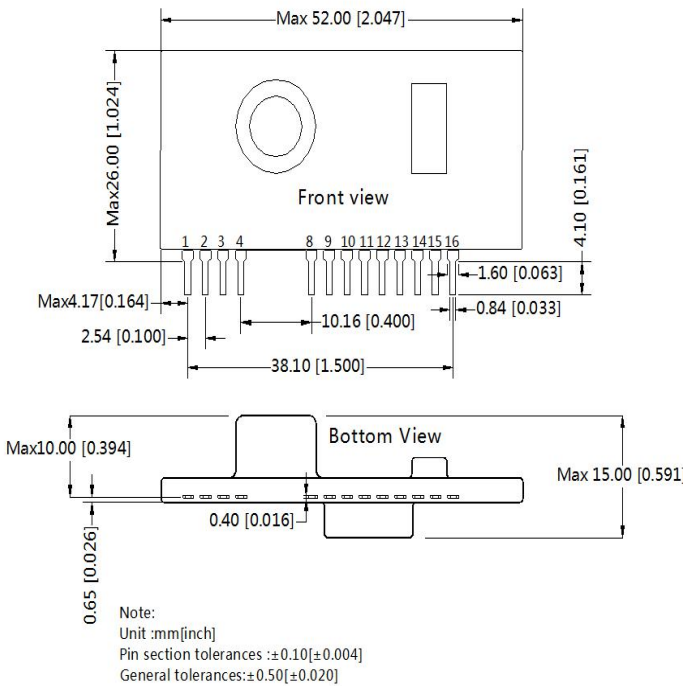

Note:Grid 2.54*2.54mm

Pin-Out			
Pin	Function	Pin	Function
1	Power supply (+)	11	Drive output
2	Power supply (-)	12	Collector of internal power tube
3	Drive signal input(+)	13	Detect of short circuit
4	Drive signal input(-)	14	Adjustment of Soft turn-off time
8	DC/DC converter output (+)	15	Fault signal output
9	DC/DC converter output (COM)	16	Adjustment of short-circuit detection time delay
10	DC/DC converter output (-)		

Notes:

1. For additional information on Product Packaging please refer to www.mornsun-power.com. The Packaging bag number: 58230001;
2. The built-in isolated DC-DC power supply is for internal driver use only and cannot be used for external connections. We recommend the output filter capacitor value not to exceed 220uF;
3. The driver must be wired as short as possible to the IGBT module's gate and emitter terminals (1m max.);
4. Twisted pair is recommended for the connection of the driver to the gate and emitter of the IGBT;
5. In order to reduce the high peak voltage generated at the collector of the IGBT turn-off, it is recommended to increase the gate resistance appropriately;
6. The additional capacitor or resistor should be placed as close as possible to the driver terminals. Do not exceed the recommended maximum values;
7. Select electrolytic capacitors for C2 and C3 with a low ESR and placed them as close as possible to the driver terminals;
8. Select a fast recovery diode D1 (connected to pin #13) with a peak reverse voltage that is higher than the peak value of the IGBT collector voltage;
9. The 30V Zener diode DZ1 is connected between pin #13 and pin #10, protecting the driver from the reverse recovery characteristic of the diode D1 which could generate an excessive voltage on pin #13;
10. 4.7KΩ resistance can be connected between pin #13 and pin # 9 if fault detection no required.(D1 and DZ1 is not required in this circuit).
11. Unless otherwise specified, parameters in this datasheet were measured under the conditions of Ta=25°C, humidity<75%RH with nominal input voltage and rated output load;
12. All index testing methods in this datasheet are based on company corporate standards;
13. The above are the performance indicators of the product models listed in this datasheet. Some indicators of non-standard models will exceed the above requirements. For details, please contact our technical staff;
14. We can provide product customization service, please contact our technicians directly for specific information;
15. Products are related to laws and regulations: see "Features" ;
16. Our products shall be classified according to ISO14001 and related environmental laws and regulations, and shall be handled by qualified units.

MORNSUN Guangzhou Science & Technology Co., Ltd.

Address: No. 5, Kehui St. 1, Kehui Development Center, Science Ave., Guangzhou Science City, Luogang District, Guangzhou, P. R. China
Tel: 86-20-38601850-8801 Fax: 86-20-38601272 E-mail: info@mornsun.cn