

## MM54C90/MM74C90 4-Bit Decade Counter MM54C93/MM74C93 4-Bit Binary Counter

### General Description

The MM54C90/MM74C90 decade counter and the MM54C93/MM74C93 binary counter and complementary MOS (CMOS) integrated circuits constructed with N- and P-channel enhancement mode transistors. The 4-bit decade counter can reset to zero or preset to nine by applying appropriate logic level on the  $R_{01}$ ,  $R_{02}$ ,  $R_{91}$  and  $R_{92}$  inputs. Also, a separate flip-flop on the A-bit enables the user to operate it as a divide-by-2, 5 or 10 frequency counter. The 4-bit binary counter can be reset to zero by applying high logic level on inputs  $R_{01}$  and  $R_{02}$ , and a separate flip-flop on the A-bit enables the user to operate it as a divide-by-2, -8, or -16 divider. Counting occurs on the negative going edge of the input pulse.

All inputs are protected against static discharge damage.

### Features

- Wide supply voltage range 3V to 15V
- Guaranteed noise margin 1V
- High noise immunity  $0.45 V_{CC}$  (typ.)
- Low power Fan out of 2 driving 74L
- TTL compatibility
- The MM54C93/MM74C93 follows the MM54L93/MM74L93 Pinout

MM54C90/MM74C90 4-Bit Decade Counter  
MM54C93/MM74C93 4-Bit Binary Counter

### Connection and Logic Diagrams

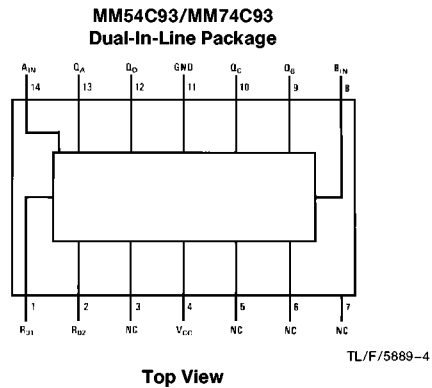
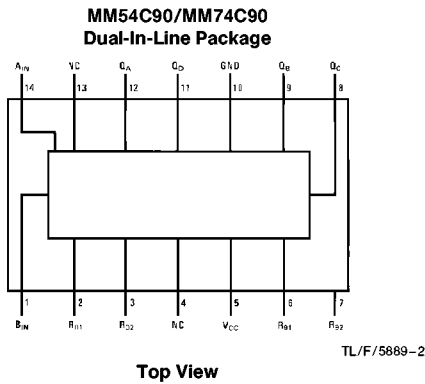

Order Number MM54C90 or MM74C93

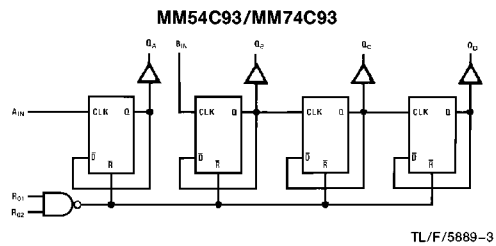
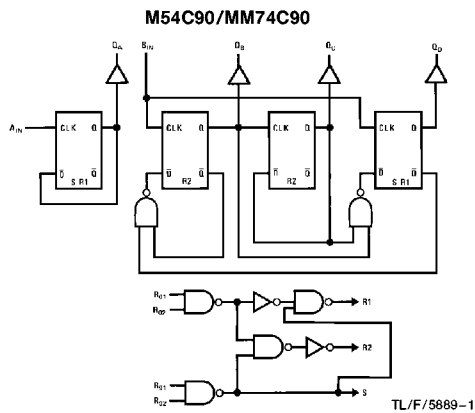

## Absolute Maximum Ratings

If Military/Aerospace specified devices are required, please contact the National Semiconductor Sales Office/Distributors for availability and specifications.

Voltage at Any Pin (Note 1)	-0.3V to $V_{CC} + 0.3V$
Operating Temperature Range ( $T_A$ )	-55°C to +125°C
MM54C90, MM54C93	-40°C to +85°C
MM74C90, MM74C93	

Power Dissipation ( $P_D$ )	
Dual-In-Line	700 mW
Small Outline	500 mW
Operating $V_{CC}$ Range	3V to 15V
Absolute Maximum $V_{CC}$	18V
Storage Temperature Range ( $T_S$ )	-65°C to +150°C
Lead Temperature ( $T_L$ )	260°C
(Soldering, 10 seconds)	

## DC Electrical Characteristics Min/Max limits apply across temperature range unless otherwise noted

Symbol	Parameter	Conditions	Min	Typ	Max	Units
<b>CMOS TO CMOS</b>						
$V_{IN(1)}$	Logical "1" Input Voltage	$V_{CC} = 5V$ $V_{CC} = 10V$	3.5 8.0			V V
$V_{IN(0)}$	Logical "0" Input Voltage	$V_{CC} = 5V$ $V_{CC} = 10V$			1.5 2.0	V V
$V_{OUT(1)}$	Logical "1" Output Voltage	$V_{CC} = 5V, I_O = -10 \mu A$ $V_{CC} = 10V, I_O = -10 \mu A$	4.5 9.0			V V
$V_{OUT(0)}$	Logical "0" Output Voltage	$V_{CC} = 5V, I_O = +10 \mu A$ $V_{CC} = 10V, I_O = +10 \mu A$			0.5 1.0	V V
$I_{IN(1)}$	Logical "1" Input Current	$V_{CC} = 15V, V_{IN} = 15V$		0.005	1.0	$\mu A$
$I_{IN(0)}$	Logical "0" Input Current	$V_{CC} = 15V, V_{IN} = 0V$	-1.0	-0.005		$\mu A$
$I_{CC}$	Supply Current	$V_{CC} = 15V$		0.05	300	$\mu A$

## CMOS/LPTTL INTERFACE

$V_{IN(1)}$	Logical "1" Input Voltage MM54C90, MM54C93 MM74C90, MM74C93	$V_{CC} = 4.5V$ $V_{CC} = 4.75V$	$V_{CC} - 1.5$ $V_{CC} - 1.5$			V V
$V_{IN(0)}$	Logical "0" Input Voltage MM54C90, MM54C93 MM74C90, MM74C93	$V_{CC} = 4.5V$ $V_{CC} = 4.75V$			0.8 0.8	V V
$V_{OUT(1)}$	Logical "1" Output Voltage MM54C90, MM54C93 MM74C90, MM74C93	$V_{CC} = 4.5V, I_O = -360 \mu A$ $V_{CC} = 4.75V, I_O = -360 \mu A$	2.4 2.4			V V
$V_{OUT(0)}$	Logical "0" Output Voltage MM54C90, MM54C93 MM74C90, MM74C93	$V_{CC} = 4.5V, I_O = -360 \mu A$ $V_{CC} = 4.75V, I_O = -360 \mu A$			0.4 0.4	V V

## OUTPUT DRIVE (See 54C/74C Family Characteristics Data Sheet) (Short Circuit Current)

$I_{SOURCE}$	Output Source Current (P-Channel)	$V_{CC} = 5V, V_{OUT} = 0V$ $T_A = 25^\circ C$	-1.75	-3.3		mA
$I_{SOURCE}$	Output Source Current (P-Channel)	$V_{CC} = 10V, V_{OUT} = 0V$ $T_A = 25^\circ C$	-8.0	-15		mA
$I_{SINK}$	Output Sink Current (N-Channel)	$V_{CC} = 5V, V_{OUT} = V_{CC}$ $T_A = 25^\circ C$	1.75	3.6		mA
$I_{SINK}$	Output Sink Current (N-Channel)	$V_{CC} = 10V, V_{OUT} = V_{CC}$ $T_A = 25^\circ C$	8.0	16		mA

**Note 1:** "Absolute Maximum Ratings" are those values beyond which the safety of the device cannot be guaranteed. Except for "Operating Temperature Range", they are not meant to imply that the devices should be operated at these limits. The table of "Electrical Characteristics" provides conditions for actual device operation.

## AC Electrical Characteristics\* $T_A = 25^\circ C, C_L = 50 pF$ , unless otherwise specified

Symbol	Parameter	Conditions	Min	Typ	Max	Units
$t_{pd0}, t_{pd1}$	Propagation Delay Time from $A_{IN}$ to $Q_A$	$V_{CC} = 5V$ $V_{CC} = 10V$		200 80	400 150	ns ns
$t_{pd0}, t_{pd1}$	Propagation Delay Time from $A_{IN}$ to $Q_B$ (MM54C93/MM74C93)	$V_{CC} = 5V$ $V_{CC} = 10V$		450 160	850 300	ns ns
$t_{pd0}, t_{pd1}$	Propagation Delay Time from $A_{IN}$ to $Q_B$ (MM54C90/MM74C90)	$V_{CC} = 5V$ $V_{CC} = 10V$		450 160	800 300	ns ns

## AC Electrical Characteristics\* $T_A = 25^\circ\text{C}$ , $C_L = 50\text{ pF}$ , unless otherwise specified (Continued)

Symbol	Parameter	Conditions	Min	Typ	Max	Units
$t_{pd0}$ , $t_{pd1}$	Propagation Delay Time from $A_{IN}$ to $Q_C$ (MM54C93/MM74C93)	$V_{CC} = 5\text{V}$ $V_{CC} = 10\text{V}$		500 200	1050 400	ns ns
$t_{pd0}$ , $t_{pd1}$	Propagation Delay Time from $A_{IN}$ to $Q_C$ (MM54C93/MM74C93)	$V_{CC} = 5\text{V}$ $V_{CC} = 10\text{V}$		500 200	1000 400	ns ns
$t_{pd0}$ , $t_{pd1}$	Propagation Delay Time from $A_{IN}$ to $Q_D$ (MM54C93/MM74C93)	$V_{CC} = 5\text{V}$ $V_{CC} = 10\text{V}$		600 250	1200 500	ns ns
$t_{pd0}$ , $t_{pd1}$	Propagation Delay Time from $A_{IN}$ to $Q_D$ (MM54C90/MM74C90)	$V_{CC} = 5\text{V}$ $V_{CC} = 10\text{V}$		450 160	800 300	ns ns
$t_{pd0}$ , $t_{pd1}$	Propagation Delay Time from $R_{01}$ or $R_{02}$ to $Q_A$ , $Q_B$ , $Q_C$ or $Q_D$ (MM54C93/MM74C93)	$V_{CC} = 5\text{V}$ $V_{CC} = 10\text{V}$		150 75	300 150	ns ns
$t_{pd0}$ , $t_{pd1}$	Propagation Delay Time from $R_{01}$ or $R_{02}$ to $Q_A$ , $Q_B$ , $Q_C$ or $Q_D$ (MM54C90/MM74C90)	$V_{CC} = 5\text{V}$ $V_{CC} = 10\text{V}$		200 75	400 150	ns ns
$t_{pd0}$ , $t_{pd1}$	Propagation Delay Time from $R_{91}$ or $R_{92}$ to $Q_A$ or $Q_D$ (MM54C90/MM74C90)	$V_{CC} = 5\text{V}$ $V_{CC} = 10\text{V}$		250 100	500 200	ns ns
$t_{PW}$	Min. $R_{01}$ or $R_{02}$ Pulse Width (MM54C93/MM74C93)	$V_{CC} = 5\text{V}$ $V_{CC} = 10\text{V}$	600 30	250 125		ns ns
$t_{PW}$	Min. $R_{01}$ or $R_{02}$ Pulse Width (MM54C90/MM74C90)	$V_{CC} = 5\text{V}$ $V_{CC} = 10\text{V}$	600 300	250 125		ns ns
$t_{PW}$	Min. $R_{91}$ or $R_{92}$ Pulse Width (MM54C90/MM74C90)	$V_{CC} = 5\text{V}$ $V_{CC} = 10\text{V}$	500 250	200 100		ns ns
$t_r$ , $t_f$	Maximum Clock Rise and Fall Time	$V_{CC} = 10\text{V}$ $V_{CC} = 10\text{V}$			15 5	$\mu\text{s}$ $\mu\text{s}$
$t_W$	Minimum Clock Pulse Width	$V_{CC} = 5\text{V}$ $V_{CC} = 10\text{V}$	250 100	100 50		ns ns
$f_{MAX}$	Maximum Clock Frequency	$V_{CC} = 5\text{V}$ $V_{CC} = 10\text{V}$	2 5			MHz MHz
$C_{IN}$	Input Capacitance	Any Input (Note 2)		5		pF
$C_{PD}$	Power Dissipation Capacitance	Per Package (Note 3)		45		pF

\*AC Parameters are guaranteed by DC correlated testing.

**Note 1:** "Absolute Maximum Ratings" are those values beyond which the safety of the device cannot be guaranteed. Except for "Operating Temperature Range", they are not meant to imply that the devices should be operated at these limits. The table of "Electrical Characteristics" provides conditions for actual device operation.

**Note 2:** Capacitance is guaranteed by periodic testing.

**Note 3:**  $C_{PD}$  determines the no load ac power consumption of any CMOS device. For complete explanation see 54C/74C Family Characteristics application note—AN-90.

## AC Test Circuits

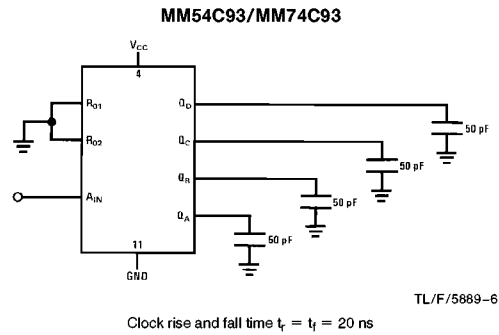
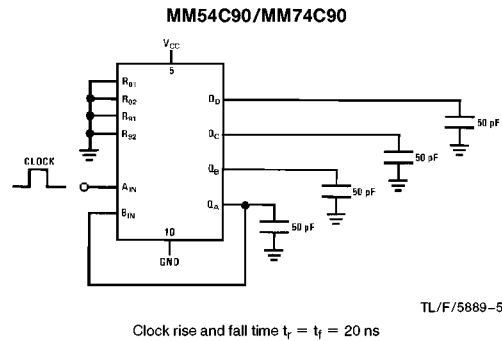

## Switching Time Waveforms

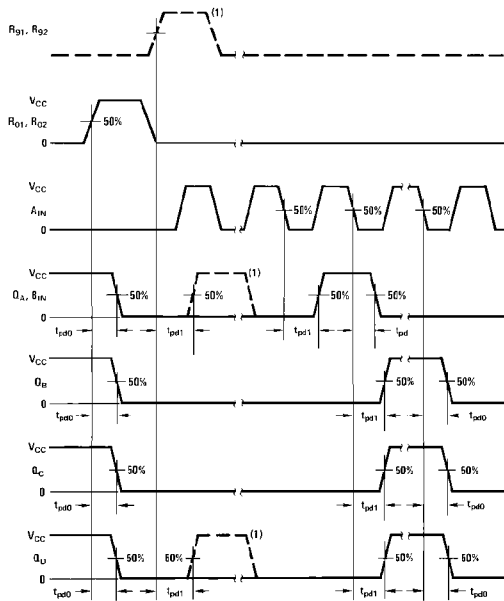

**Note 1:** MM54C90, MM74C90 and MM54C93, MM74C93 are solid line waveforms. Dashed line waveforms are for MM54C90/MM74C90 only.

TL/F/5889-7

## Truth Table

**MM54C90/MM74C90 4-Bit Decade Counter**

### BCD Count Sequence

Count	Output			
	Q <sub>D</sub>	Q <sub>C</sub>	Q <sub>B</sub>	Q <sub>A</sub>
0	L	L	L	L
1	L	L	L	H
2	L	L	H	L
3	L	L	H	H
4	L	H	L	L
5	L	H	L	H
6	L	H	H	L
7	L	H	H	H
8	H	L	L	L
9	H	L	L	H

Output Q<sub>A</sub> is connected to Input B for BCD count.

H = High Level  
L = Low Level  
X = Irrelevant

### Reset/Count Function Table

Reset Inputs				Output			
R <sub>01</sub>	R <sub>02</sub>	R <sub>91</sub>	R <sub>92</sub>	Q <sub>D</sub>	Q <sub>C</sub>	Q <sub>B</sub>	Q <sub>A</sub>
H	H	L	X	L	L	L	L
H	H	X	L	L	L	L	L
X	X	H	H	H	L	L	H
X	L	X	L	Count			
L	X	L	X	Count			
L	X	X	L	Count			
X	L	L	X	Count			

**MM54C93/MM74C93 4-Bit Binary Counter**

### Binary Count Sequence

Count	Output			
	Q <sub>D</sub>	Q <sub>C</sub>	Q <sub>B</sub>	Q <sub>A</sub>
0	L	L	L	L
1	L	L	L	H
2	L	L	H	L
3	L	L	H	H
4	L	H	L	L
5	L	H	L	H
6	L	H	H	L
7	L	H	H	H
8	H	L	L	L
9	H	L	L	H
10	H	L	H	L
11	H	L	H	H
12	H	H	L	L
13	H	H	L	H
14	H	H	H	L
15	H	H	H	H

Output Q<sub>A</sub> is connected to input B for binary count sequence.

H = High Level  
L = Low Level  
X = Irrelevant

### Reset/Count Function Table

Reset Inputs		Output			
R <sub>01</sub>	R <sub>02</sub>	Q <sub>D</sub>	Q <sub>C</sub>	Q <sub>B</sub>	Q <sub>A</sub>
H	H	L	L	L	L
L	X	Count			
X	L	Count			

**Physical Dimensions** inches (millimeters)

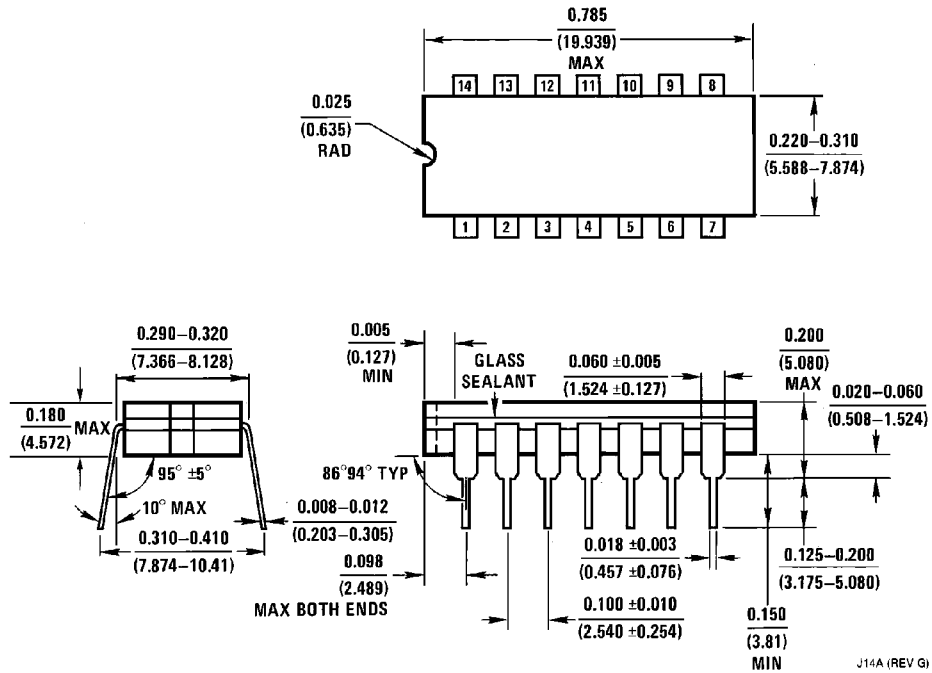

**Ceramic Dual-In-Line Package (J)**  
**Order Number MM54C90J, MM54C93J, MM74C90J or MM74C93J**  
**NS Package Number J14A**

J14A (REV G)

**MM54C90/MM74C90 4-Bit Decade Counter  
MM54C93/MM74C93 4-Bit Binary Counter**

**Physical Dimensions** inches (millimeters) (Continued)

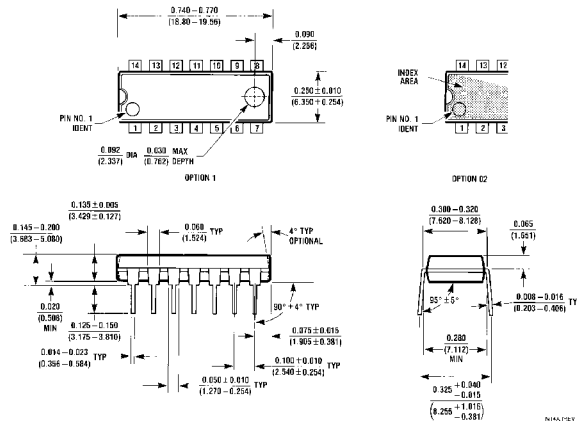

**Molded Dual-In-Line Package (N)**  
**Order Number MM54C90N, MM54C93N, MM74C90N or MM74C93N**  
**NS Package Number N14A**

**LIFE SUPPORT POLICY**

NATIONAL'S PRODUCTS ARE NOT AUTHORIZED FOR USE AS CRITICAL COMPONENTS IN LIFE SUPPORT DEVICES OR SYSTEMS WITHOUT THE EXPRESS WRITTEN APPROVAL OF THE PRESIDENT OF NATIONAL SEMICONDUCTOR CORPORATION. As used herein:

1. Life support devices or systems are devices or systems which, (a) are intended for surgical implant into the body, or (b) support or sustain life, and whose failure to perform, when properly used in accordance with instructions for use provided in the labeling, can be reasonably expected to result in a significant injury to the user.
2. A critical component is any component of a life support device or system whose failure to perform can be reasonably expected to cause the failure of the life support device or system, or to affect its safety or effectiveness.



**National Semiconductor Corporation**  
 1111 West Bardin Road  
 Arlington, TX 76017  
 Tel: 1(800) 272-9959  
 Fax: 1(800) 737-7018

**National Semiconductor Europe**  
 Fax: (+49) 0-180-530 85 86  
 Email: onjwgs@tevm2.nsc.com  
 Deutsch Tel: (+49) 0-180-530 85 85  
 English Tel: (+49) 0-180-532 78 32  
 Français Tel: (+49) 0-180-532 93 58  
 Italiano Tel: (+49) 0-180-534 16 80

**National Semiconductor Hong Kong Ltd.**  
 13th Floor, Straight Block,  
 Ocean Centre, 5 Canton Rd.  
 Tsimshatsui, Kowloon  
 Hong Kong  
 Tel: (852) 2737-1600  
 Fax: (852) 2736-9960

**National Semiconductor Japan Ltd.**  
 Tel: 81-043-299-2309  
 Fax: 81-043-299-2408

National does not assume any responsibility for use of any circuitry described, no circuit patent licenses are implied and National reserves the right at any time without notice to change said circuitry and specifications.