

SENTRY

AUTOMATICALLY THE BETTER CHOICE

STANDARD PRODCUTS
TWO CHANNEL 433MHz
GENERAL PURPOSE RECEIVER

REMOTE CONTROLS

The SENTRY Two Channel General Purpose Receiver is a two channel receiver for general control purposes. It is fully compatible with ALL SENTRY code hopping transmitters in all button formats, and can learn up to 20 unique transmitter buttons, and provides two linked relay control channels, each capable of switching typically 5 to 10 amperes at 230V AC.

The primary control channel relay is of the latching type, and the secondary control channel is of the pulsed type (typical pulse time approx 2 seconds). This mode of operation makes the product versatile. It also makes it possible to use this product to control modern electronic LED type pool lamps easily and cost effectively.

This product is offered in two versions:
Standard 16V AC/DC version
230V AC version (built-in transformer)

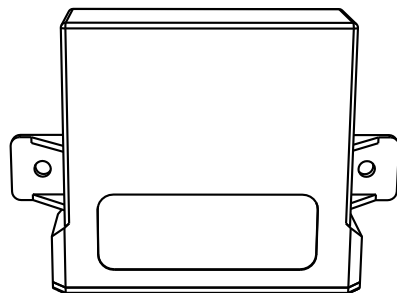
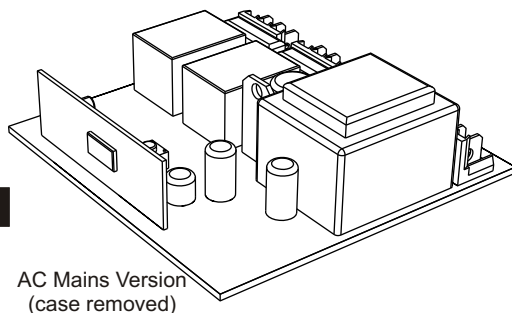
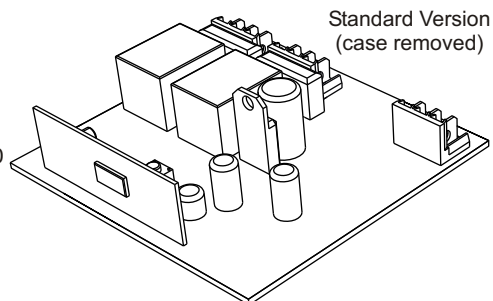

TECHNICAL SPECIFICATIONS

Transmission Frequency:	433.92MHz
Modulation Format:	ASK
Protocol:	Code Hopping
Power Source:	16V AC or DC 200 - 250V AC 50 - 60Hz 1.5VA
Relay Contacts:	5A @ 240V AC
Dimensions:	90mm x 87mm x 31mm
Mass:	< 373g
Operating Temperature Range:	-30°C to +55°C
Current Consumption: (test supply 13.8VDC)	10mA (idle) 40mA (RELAY 1 active) 70mA (both RELAY 1 & 2 active)

DO NOT EXCEED RELAY RATINGS
5A max. (RESISTIVE LOADS)
3A max. (INDUCTIVE LOADS)

MARTIN ELECTRONICS

Sentry Place
26 Kindon Road, Robertsham Industrial
Gauteng, South Africa
+27 11 433 4084
www.martin-electronics.co.za



ETSI 300 220-1
ETSI 300 683
MPT 1340

PROGRAMMING AND USAGE

MODE OF OPERATION

The primary channel (Relay 1) operates with a latch function, therefore it toggles on, or off with each successive button press on the transmitter. The secondary channel (Relay 2) operates in the pulsed mode i.e. it will activate for 2 seconds, then drop out with each command received from the transmitter. However, they are linked: If Relay 1 is not latched on, Relay 2 does not operate. (This provides the necessary control logic for most standard LED type swimming pool lamps). For each relay, a button on the remote control must be "mapped" to the relay concerned during the learning procedure.

PROGRAMMING PROCEDURE

(Example shown with SENTRY 4 button transmitter)
To program a remote control into the receiver, the following procedure applies:

Step 1:
PRESS AND RELEASE the learn button on the receiver. The receiver will then enter "learn mode" indicated by the green LED flashing steady. At the same time, the RED LED designated to RELAY 1 will turn on. At the same time RELAY 1 will energise.

Step 2:
Press the Button you wish to assign to RELAY 1, on the remote control. If successful, the green LED will flash rapidly, indicating that the button was stored successfully. After approximately 1 second, the green LED extinguishes, and the relay will de-energise. This indicates LEARN MODE is exited and the receiver returns to normal operation. At this point the button is now learnt in and the primary relay channel (RELAY 1) will operate in latch mode, which can be confirmed if you press the button on the transmitter.

Step 3: (Optional if used as normal receiver)
PRESS AND RELEASE the learn button on the receiver. The receiver once again enters "learn mode" (green LED flashing and the red LED along with RELAY 1, is turned on). Now, press and release the LEARN button again, Relay 1 and its LED indicator turn off, Relay 2, and its LED indicator now turn on. Press the button on the remote you wish to assign to this relay (must be a button other than the one assigned to RELAY 1). If successful, the green LED flashes rapidly, then extinguishes, and RELAY 2 turns off together with its LED indicator.

Erasing All Buttons Stored in memory

To erase all buttons stored in memory and to revert the receiver to the factory shipped condition, proceed as follows:

1. Press and HOLD the LEARN button for at least 2 seconds... After 2 seconds, both RELAY 1 and 2 will turn on, together with their LED indicators.
2. Release the LEARN button. The relays remain energized for a further 2 seconds. They then release simultaneously. This indicates the memory has been erased.

Figure 1. Receiver Feature Locations

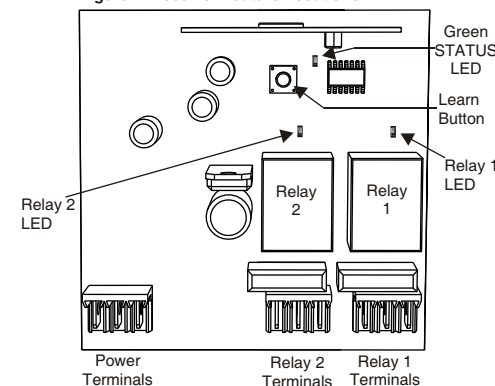

There may be lethal voltages present when this unit is in circuit, therefore always disconnect the relays by unplugging the respective terminal blocks before doing any programming on the unit.

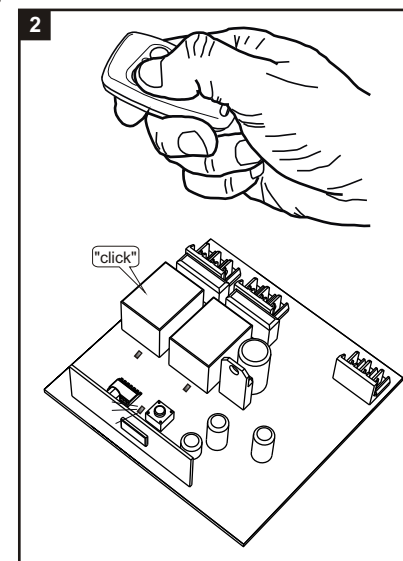
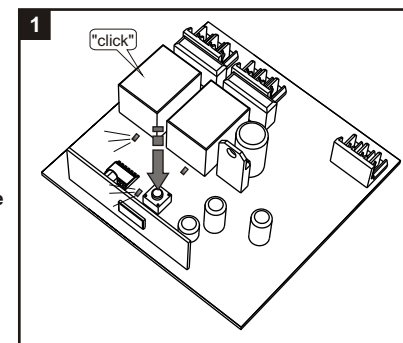

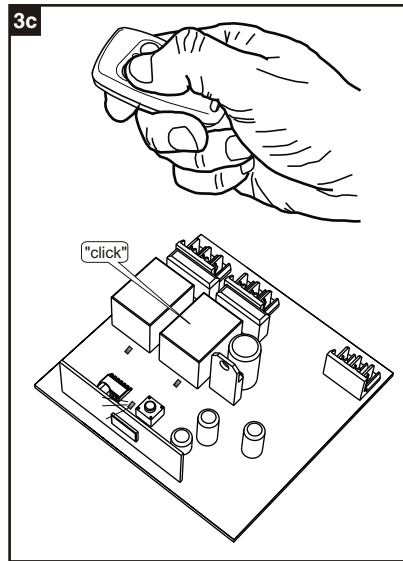
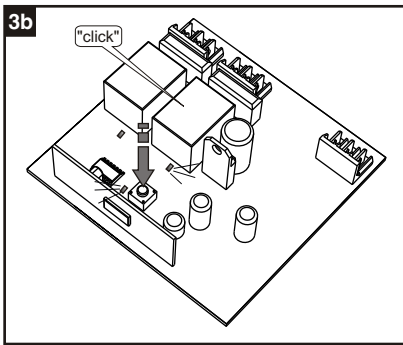
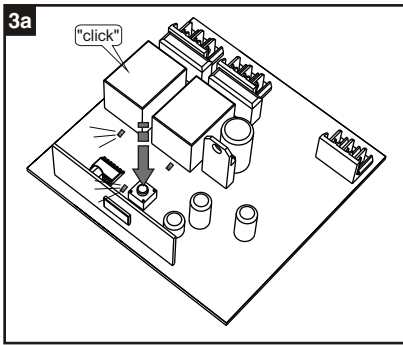

ELECTRICAL CONNECTIVITY

Electrical Schematic Diagram - DC Version

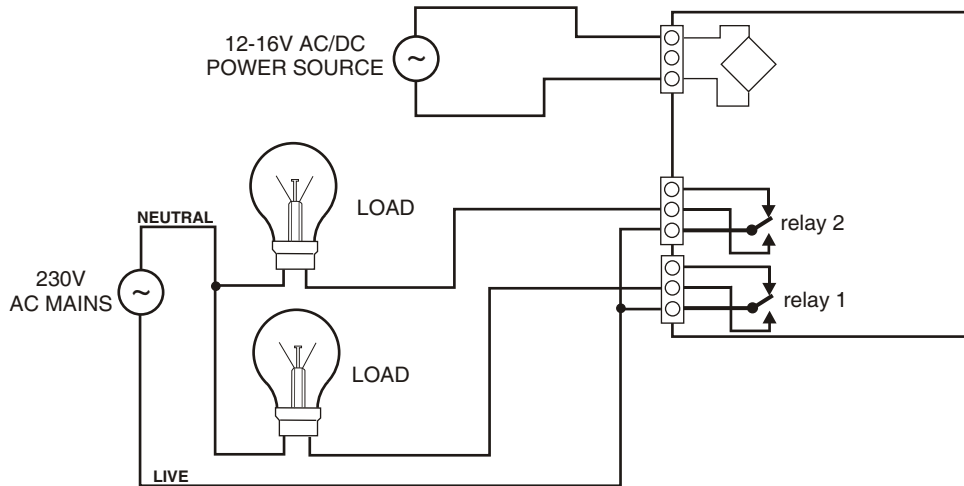

! MAKE SURE YOU HAVE THE CORRECT RECEIVER TYPE FOR THE POWER SOURCE YOU INTEND TO USE. USING THE WRONG RECEIVER VERSION ON MAINS POWER WILL DESTROY THE PRODUCT AND LEAD TO PERSONAL INJURY OR FIRE

ELECTRICAL CONNECTIVITY

Electrical Schematic Diagram - AC Mains Version

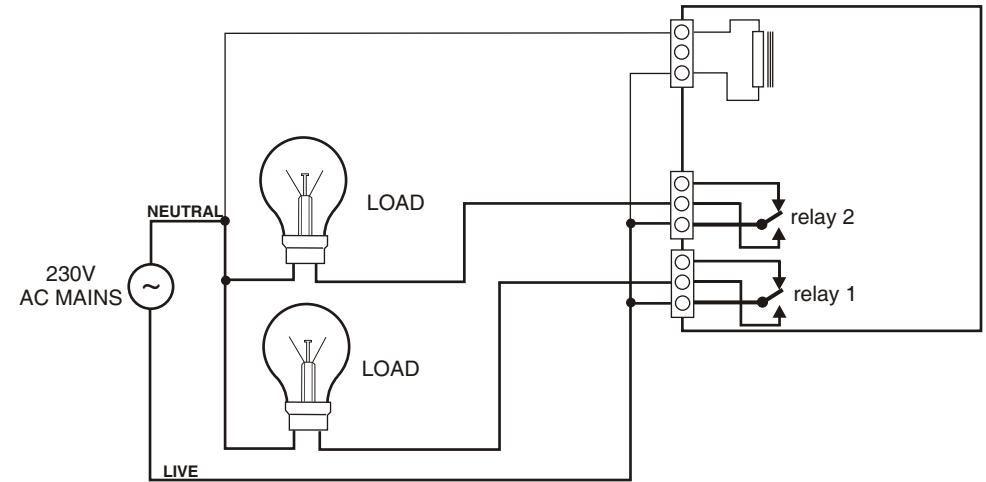

! MAKE SURE YOU HAVE THE CORRECT RECEIVER TYPE FOR THE POWER SOURCE YOU INTEND TO USE. USING THE WRONG RECEIVER VERSION ON MAINS POWER WILL DESTROY THE PRODUCT AND LEAD TO PERSONAL INJURY OR FIRE

ELECTRICAL TERMINATIONS

This product is supplied with pluggable terminal blocks to make it easy to disconnect and or reconnect the product from an installation if and when necessary, without having to unscrew the wires. The following diagrams illustrate how to use these connectors...

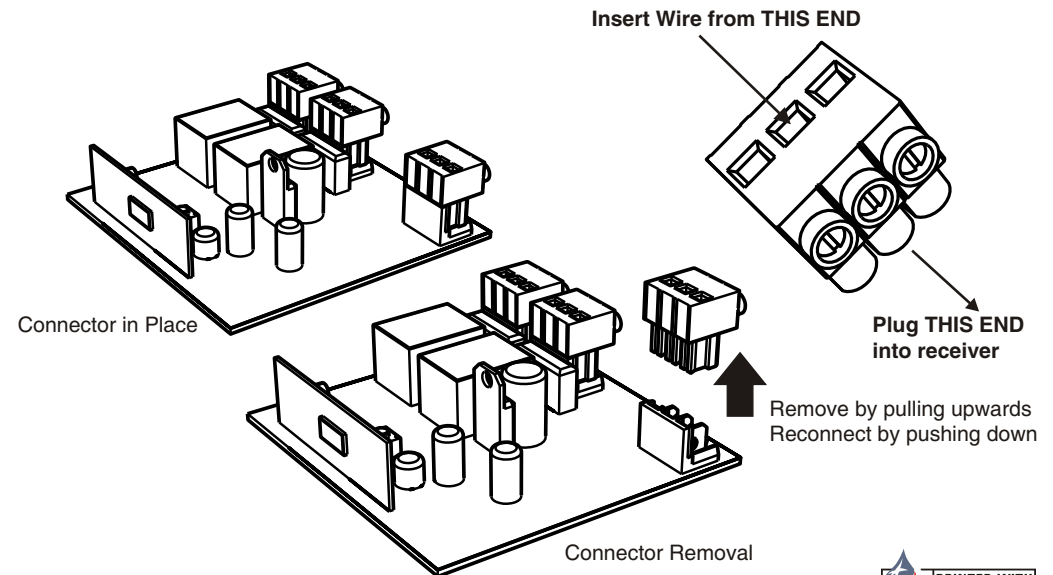

THIS PRODUCT IS SOLD SUBJECT TO OUR STANDARD TERMS AND CONDITIONS, WHICH MAY BE OBTAINED ON REQUEST FROM MARTIN ELECTRONICS (011) 433 4084 or www.martin-electronics.co.za