

# APPROVAL SHEET

Product: Electret Condenser Microphone

<b>Model</b>	<b>MD06027BPN-12</b>
<b>Customer name</b>	
<b>Sensitivity</b>	<b>-46 ± 3dB</b>
<b>Test Condition</b>	<b>4.5V 2.2K Ω</b>

<b>DESIGNED BY</b>	William Liu
<b>REVISED BY</b>	George Liu
<b>APPROVED BY</b>	Jeremy Feng
<b>SUBMISSION DATE</b>	2012/11/26

**CUSTOMER:**

**P/N of Customer:**

<b>APPROVED BY</b>	<b>APPROVED DATE</b>

Customer:

P/N:

Smp No:

Eng No:

## ELECTRET CONDENSER MICROPHONE

● MODEL: MDO6027BPN-12

● CUSTOMER:

### 1. Electrical characteristics:

Directivity	Omni directional
Pb containation Requirement	Lead free
Charging type	Diaphragm
Sensitivity	$-46 \pm 3\text{dB}$ (0dB=1V/Pa, 1KHz)
Output impedance	Low impedance
Standard operating voltage	4.5V
Operating voltage range	1V-10V
Current consumption	less than 500 $\mu\text{A}$
Voltage deduction characteristic	Within 3dB at 1.0V
S/N Ratio	More than 60dB (SPL=1Pa, 1KHz, A-weighting)

### 2. Frequency Response and Schematic Diagram:

#### 2.1 Typical Frequency Response Curve:

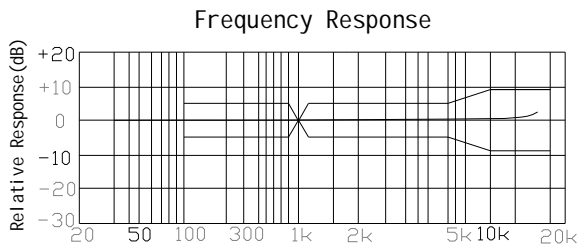

Microphone Response Tolerance Window

Frequency (Hz)	Lower Limit (dB)	Upper Limit (dB)
100	-5	5
200	-5	5
800	-5	5
1000	0	0
1200	-5	5
2000	-5	5
5000	-5	5
10000	-8	8

#### 2.2 Schematic Diagram:

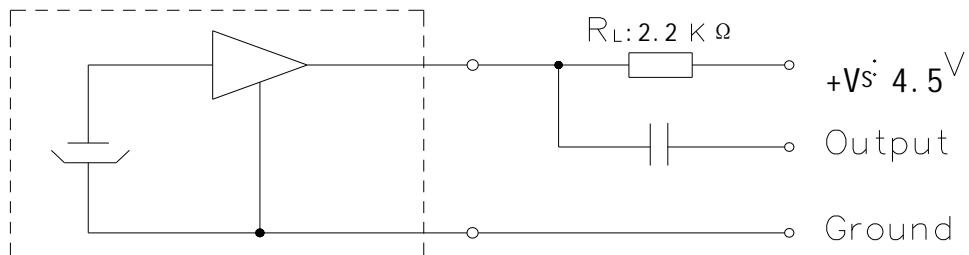

### 3. Mechanical characteristics:

- 3.1 Weight: Less than 0.6g
- 3.2 Dimension:  
Unit: mm

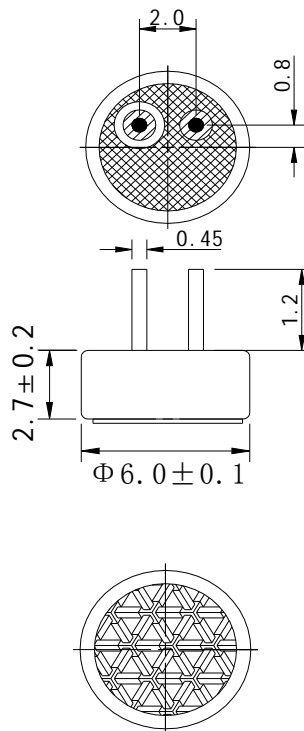

### 4. Soldering Condition

- 4.1 The soldering copper of a small type of 13~20W shall be applied.
- 4.2 The temperature of the working surface of the soldering copper shall be below 320°C.
- 4.3 ECM shall be soldered fixed on the metal block (heat sink), which has the higher radiation effects said heat sink shall contact with of ECM.
- 4.4 The soldering time for each terminal shall be 1~2 sec.
- 4.5 The pinhole after soldering shall be avoided.
- 4.6 ECM may easily destroyed by the static electricity and the countermeasure for eliminating the static electricity (the ground for soldering copper, for worktable and for human body) shall be executed.

5. PACKAGING:

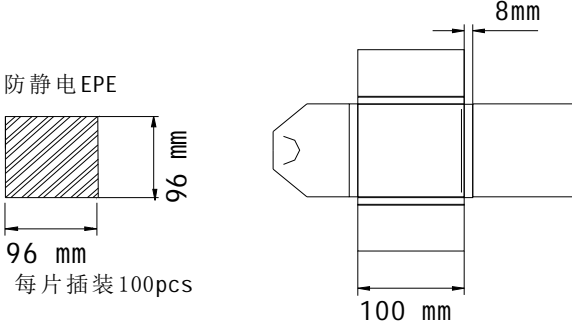
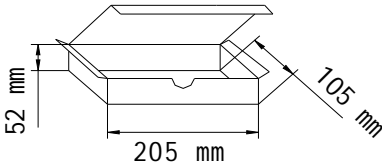
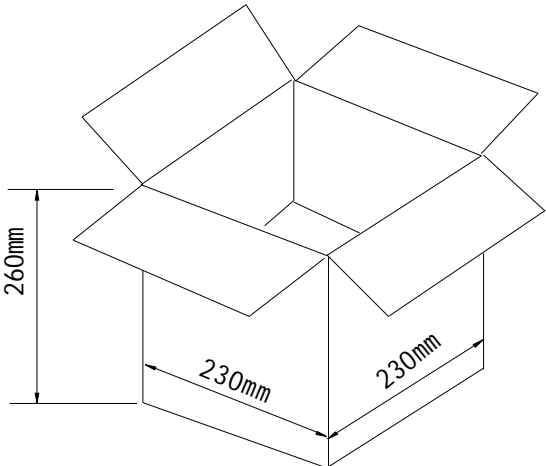
<p>小包装</p>	<p>SMALL PACKET 100mm*100mm*8mm 100PCS/ INHALE SMALL BOX</p>	 <p>防静电EPE 96 mm 96 mm 每片插装100pcs 8mm 100 mm</p>
<p>中包装</p>	<p>MID PACKET: 205mm*105mm*52mm 1000PCS/MID PACKET</p>	 <p>52 mm 205 mm 105 mm 中包装盒 (1000只)</p>
<p>大包装</p>	<p>PAPER CASE: 230mm*230mm*260mm 10000PCS/PAPER CASE</p>	 <p>260mm 230mm 230mm 中包装箱 (10000只)</p>

6 . TEST SETUP DRAWING

5.1 Standard Frequency Response Test

*Anechoic Room*

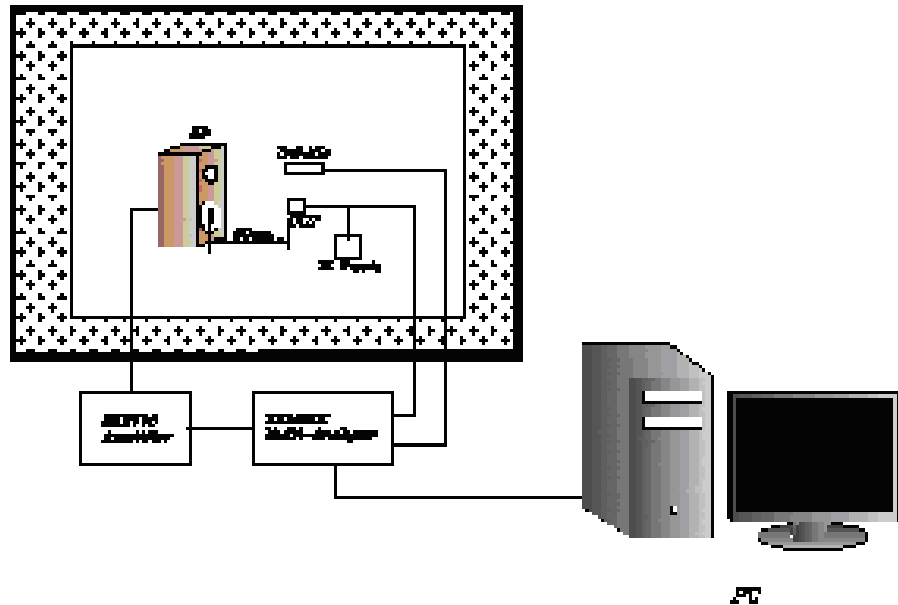

5.2 S/N Ratio Test

*Anechoic Room*

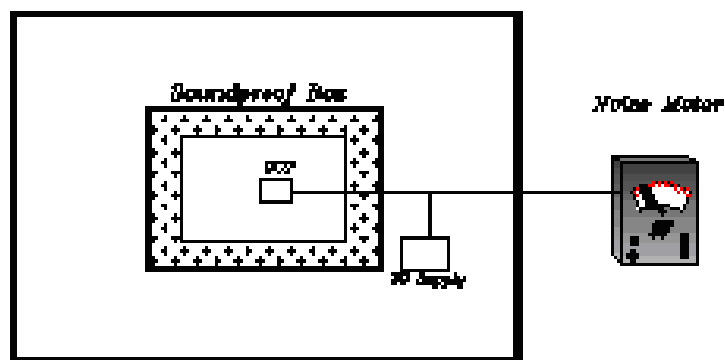

## 7. Reliability test:

Item		Test condition	Evaluation
1	High temperature Test	The part shall be capable of with- standing a storage temperature of +70 °C for 200 hours.	After the test the ECM unit shall meet the requirement of no more than ±3dB variation from initial sensitivity after 2 hours recovering.
2	Low temperature Test	The part shall be capable of with- standing a storage temperature of -20 °C for 200 hours.	
3	Temperature cycle test	The part shall be subjected to 5 cycle. One cycle shall consist of ( +70 °C ,30min → Room temp(+20°C), 10min→-20°C30min →Room temp(+20°C), 10min)	
4	Humidity Test	The part shall be capable of with- standing a storage of humidity of 90 ~ 95% at the +40°C for 200 hours.	
5	Drop Test	The microphone unit without package must be subjected to each 3 drops at three axes from the height of 1 meter to 20 mm thick hardwood board.	
6	Vibration Test	The microphone unit must be subjected to each 2 hours vibrations at three axes 2mm dynamic range, 10~50Hz/minute.	
7	Soldering Heat Resistance	Soldering iron of +330 ± 5 °C should be placed on the terminal for 2±0.5 seconds.	

## 8. Drawing

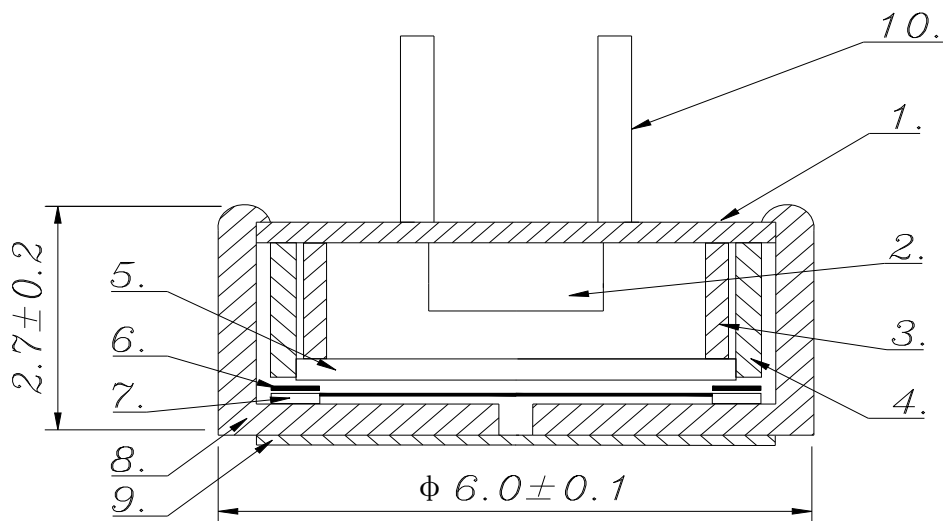

1	PCB	7	振膜
2	FET	8	外壳
3	金环	9	防水网
4	塑环腔体	10	PIN
5	极板	11	
6	垫片	12	