

# Three-Terminal Adjustable Output Positive Voltage Regulator

The LM317 is an adjustable 3-terminal positive voltage regulator capable of supplying in excess of 1.5 A over an output voltage range of 1.2 V to 37 V. This voltage regulator is exceptionally easy to use and requires only two external resistors to set the output voltage. Further, it employs internal current limiting, thermal shutdown and safe area compensation, making it essentially blow-out proof.

The LM317 serves a wide variety of applications including local, on card regulation. This device can also be used to make a programmable output regulator, or by connecting a fixed resistor between the adjustment and output, the LM317 can be used as a precision current regulator.

- Output Current in Excess of 1.5 A
- Output Adjustable between 1.2 V and 37 V
- Internal Thermal Overload Protection
- Internal Short Circuit Current Limiting Constant with Temperature
- Output Transistor Safe-Area Compensation
- Floating Operation for High Voltage Applications
- Available in Surface Mount D<sup>2</sup>PAK, and Standard 3-Lead Transistor Package
- Eliminates Stocking many Fixed Voltages

## Standard Application

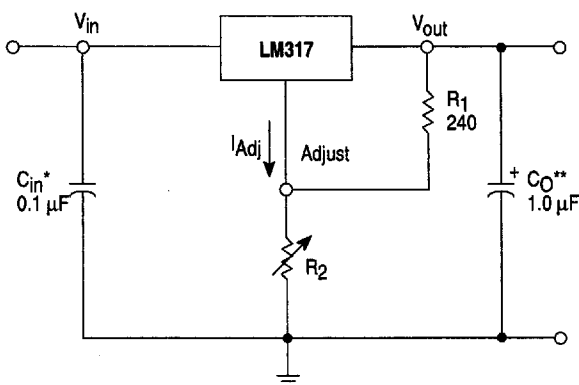

\*  $C_{in}$  is required if regulator is located an appreciable distance from power supply filter.  
 \*\*  $C_O$  is not needed for stability, however, it does improve transient response.

$$V_{out} = 1.25 V \left( 1 + \frac{R_2}{R_1} \right) + I_{Adj} R_2$$

Since  $I_{Adj}$  is controlled to less than 100  $\mu A$ , the error associated with this term is negligible in most applications.

## LM317

### THREE-TERMINAL ADJUSTABLE POSITIVE VOLTAGE REGULATOR

#### SEMICONDUCTOR TECHNICAL DATA

**T SUFFIX**  
 PLASTIC PACKAGE  
 CASE 221A

Heatsink surface  
 connected to Pin 2.

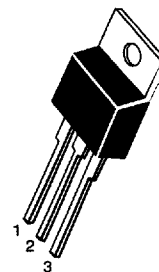

Pin 1. Adjust  
 2.  $V_{out}$   
 3.  $V_{in}$

**D2T SUFFIX**  
 PLASTIC PACKAGE  
 CASE 936  
 (D<sup>2</sup>PAK)

Heatsink surface (shown as terminal 4 in  
 case outline drawing) is connected to Pin 2.

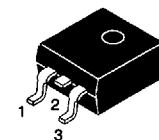

#### ORDERING INFORMATION

Device	Operating Temperature Range	Package
LM317BD2T	$T_J = -40^\circ$ to $+125^\circ C$	Surface Mount
LM317BT		Insertion Mount
LM317D2T	$T_J = 0^\circ$ to $+125^\circ C$	Surface Mount
LM317T		Insertion Mount

# LM317

## MAXIMUM RATINGS

Rating	Symbol	Value	Unit
Input-Output Voltage Differential	$V_I-V_O$	40	Vdc
Power Dissipation			
Case 221A			
$T_A = +25^\circ\text{C}$	$P_D$	Internally Limited	W
Thermal Resistance, Junction-to-Ambient	$\theta_{JA}$	65	$^\circ\text{C/W}$
Thermal Resistance, Junction-to-Case	$\theta_{JC}$	5.0	$^\circ\text{C/W}$
Case 936 (D <sup>2</sup> PAK)			
$T_A = +25^\circ\text{C}$	$P_D$	Internally Limited	W
Thermal Resistance, Junction-to-Ambient	$\theta_{JA}$	70	$^\circ\text{C/W}$
Thermal Resistance, Junction-to-Case	$\theta_{JC}$	5.0	$^\circ\text{C/W}$
Operating Junction Temperature Range	$T_J$	-40 to +125	$^\circ\text{C}$
Storage Temperature Range	$T_{stg}$	-65 to +150	$^\circ\text{C}$

**ELECTRICAL CHARACTERISTICS** ( $V_I-V_O = 5.0\text{ V}$ ;  $I_O = 0.5\text{ A}$  for D2T and T packages;  $T_J = T_{low}$  to  $T_{high}$  [Note 1];  $I_{max}$  and  $P_{max}$  [Note 2]; unless otherwise noted.)

Characteristics	Figure	Symbol	Min	Typ	Max	Unit
Line Regulation (Note 3), $T_A = +25^\circ\text{C}$ , $3.0\text{ V} \leq V_I-V_O \leq 40\text{ V}$	1	Regline	-	0.01	0.04	%/V
Load Regulation (Note 3), $T_A = +25^\circ\text{C}$ , $10\text{ mA} \leq I_O \leq I_{max}$ $V_O \leq 5.0\text{ V}$ $V_O \geq 5.0\text{ V}$	2	Regload	- -	5.0 0.1	25 0.5	mV % $V_O$
Thermal Regulation, $T_A = +25^\circ\text{C}$ (Note 6), 20 ms Pulse		Regtherm	-	0.03	0.07	% $V_O$ /W
Adjustment Pin Current	3	$I_{Adj}$	-	50	100	$\mu\text{A}$
Adjustment Pin Current Change, $2.5\text{ V} \leq V_I-V_O \leq 40\text{ V}$ , $10\text{ mA} \leq I_L \leq I_{max}$ , $P_D \leq P_{max}$	1, 2	$\Delta I_{Adj}$	-	0.2	5.0	$\mu\text{A}$
Reference Voltage, $3.0\text{ V} \leq V_I-V_O \leq 40\text{ V}$ , $10\text{ mA} \leq I_O \leq I_{max}$ , $P_D \leq P_{max}$	3	$V_{ref}$	1.2	1.25	1.3	V
Line Regulation (Note 3), $3.0\text{ V} \leq V_I-V_O \leq 40\text{ V}$	1	Regline	-	0.02	0.07	% V
Load Regulation (Note 3), $10\text{ mA} \leq I_O \leq I_{max}$ $V_O \leq 5.0\text{ V}$ $V_O \geq 5.0\text{ V}$	2	Regload	- -	20 0.3	70 1.5	mV % $V_O$
Temperature Stability ( $T_{low} \leq T_J \leq T_{high}$ )	3	$T_S$	-	0.7	-	% $V_O$
Minimum Load Current to Maintain Regulation ( $V_I-V_O = 40\text{ V}$ )	3	$I_{Lmin}$	-	3.5	10	mA
Maximum Output Current $V_I-V_O \leq 15\text{ V}$ , $P_D \leq P_{max}$ , T Package $V_I-V_O = 40\text{ V}$ , $P_D \leq P_{max}$ , $T_A = +25^\circ\text{C}$ , T Package	3	$I_{max}$	1.5 0.15	2.2 0.4	- -	A
RMS Noise, % of $V_O$ , $T_A = +25^\circ\text{C}$ , $10\text{ Hz} \leq f \leq 10\text{ kHz}$		N	-	0.003	-	% $V_O$
Ripple Rejection, $V_O = 10\text{ V}$ , $f = 120\text{ Hz}$ (Note 4) Without $C_{Adj}$ $C_{Adj} = 10\text{ }\mu\text{F}$	4	RR	- 66	65 80	- -	dB
Long-Term Stability, $T_J = T_{high}$ (Note 5), $T_A = +25^\circ\text{C}$ for Endpoint Measurements	3	S	-	0.3	1.0	%/1.0 k Hrs.
Thermal Resistance Junction to Case, T Package		$R_{\theta JC}$	-	5.0	-	$^\circ\text{C/W}$

**NOTES:** 1.  $T_{low}$  to  $T_{high} = 0^\circ$  to  $+125^\circ\text{C}$ , for LM317T, D2T.  $T_{low}$  to  $T_{high} = -40^\circ$  to  $+125^\circ\text{C}$ , for LM317BT, BD2T.

2.  $I_{max} = 1.5\text{ A}$ ,  $P_{max} = 20\text{ W}$

3. Load and line regulation are specified at constant junction temperature. Changes in  $V_O$  due to heating effects must be taken into account separately. Pulse testing with low duty cycle is used.

4.  $C_{Adj}$ , when used, is connected between the adjustment pin and ground.

5. Since Long-Term Stability cannot be measured on each device before shipment, this specification is an engineering estimate of average stability from lot to lot.

6. Power dissipation within an IC voltage regulator produces a temperature gradient on the die, affecting individual IC components on the die. These effects can be minimized by proper integrated circuit design and layout techniques. Thermal Regulation is the effect of these temperature gradients on the output voltage and is expressed in percentage of output change per watt of power change in a specified time.

# LM317

## Representative Schematic Diagram

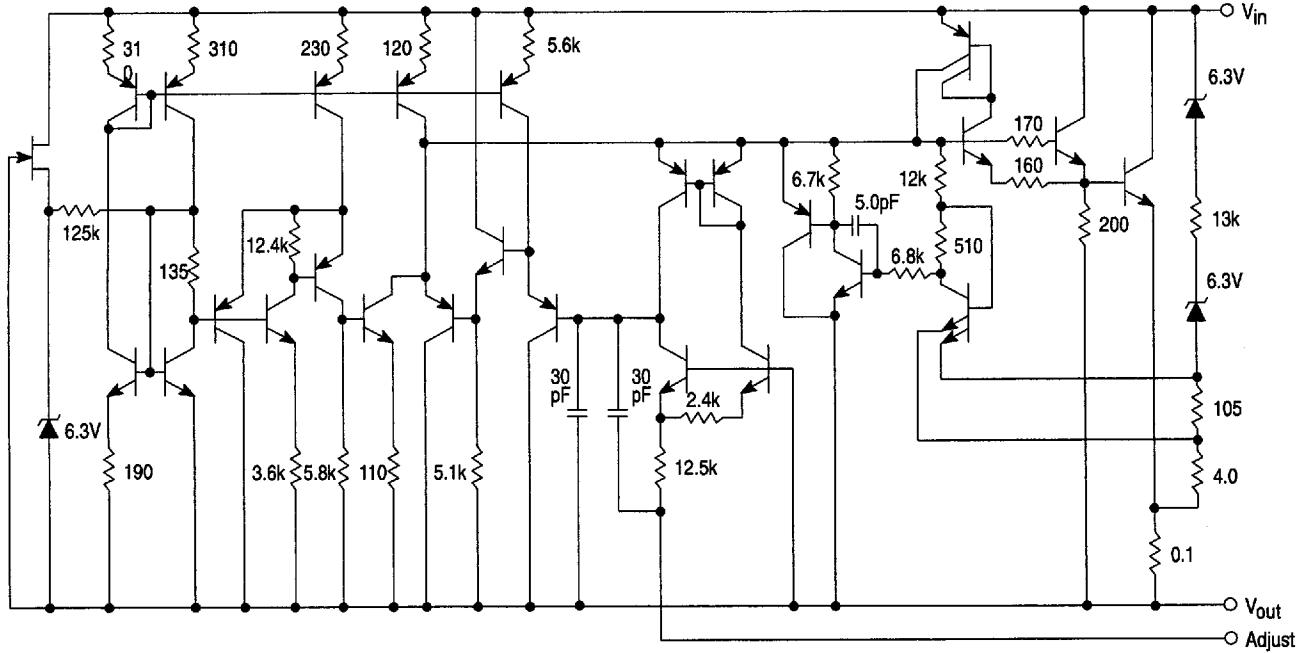

This device contains 29 active transistors.

Figure 1. Line Regulation and  $\Delta I_{Adj}/Line$  Test Circuit

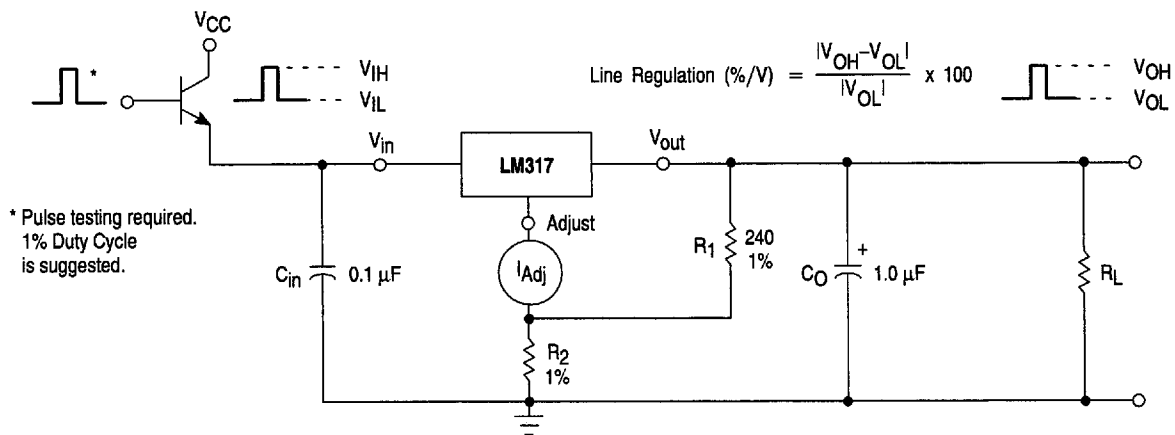

# LM317

### Figure 2. Load Regulation and $\Delta I_{Adj}$ /Load Test Circuit

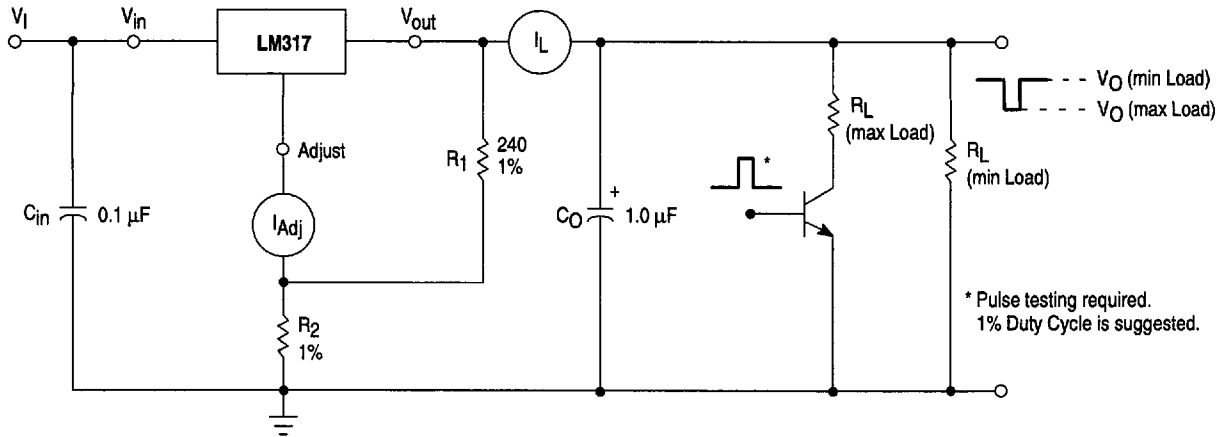

$$\text{Load Regulation (mV)} = V_O (\text{min Load}) - V_O (\text{max Load})$$

$$\text{Load Regulation (\% } V_O) = \frac{V_O (\text{min Load}) - V_O (\text{max Load})}{V_O (\text{min Load})} \times 100$$

### Figure 3. Standard Test Circuit

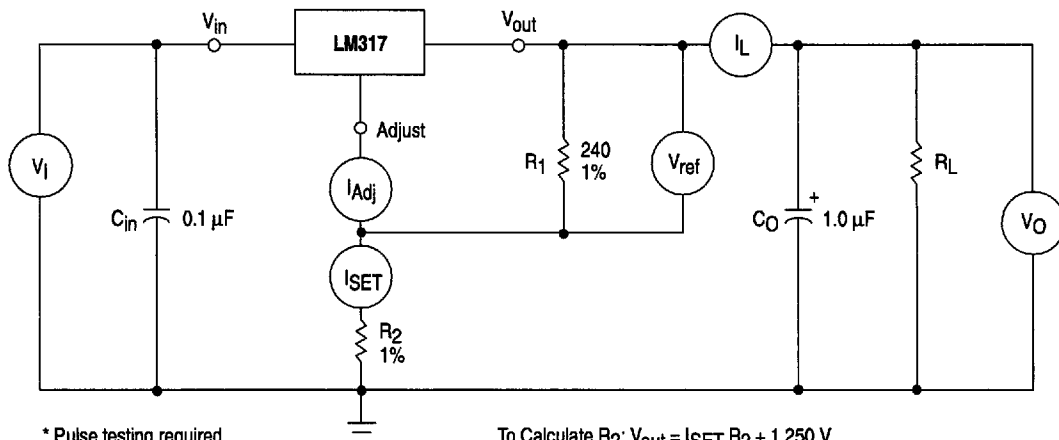

\* Pulse testing required.  
1% Duty Cycle is suggested.

To Calculate  $R_2$ :  $V_{out} = I_{SET} R_2 + 1.250 \text{ V}$   
Assume  $I_{SET} = 5.25 \text{ mA}$

### Figure 4. Ripple Rejection Test Circuit

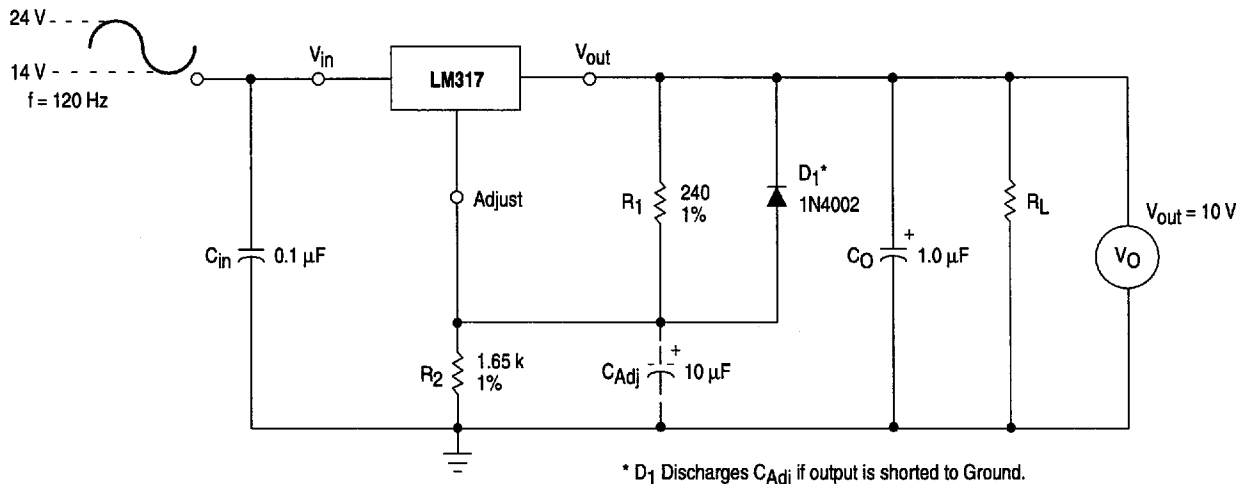

\*  $D_1$  Discharges  $C_{Adj}$  if output is shorted to Ground.

Figure 5. Load Regulation

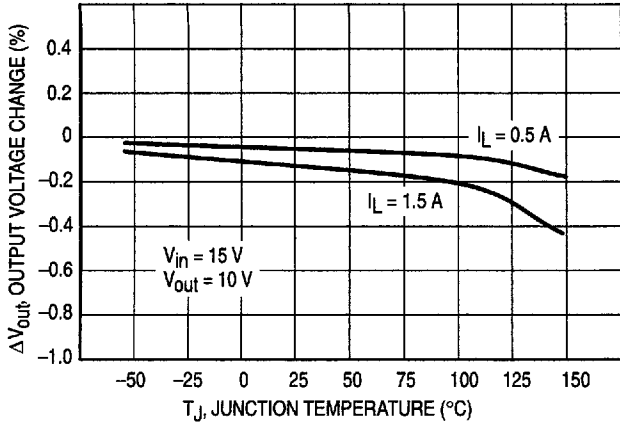

Figure 6. Current Limit

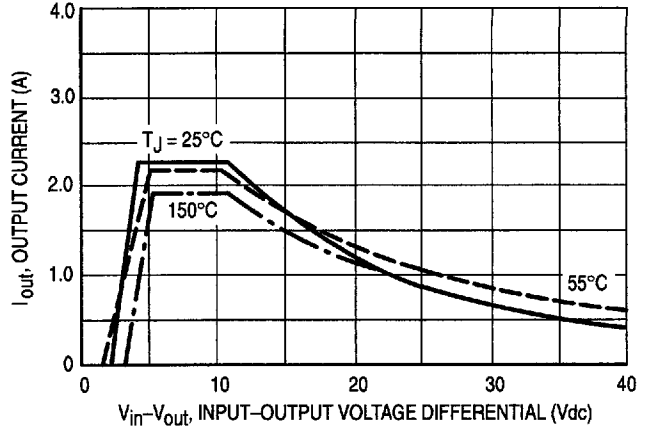

Figure 7. Adjustment Pin Current

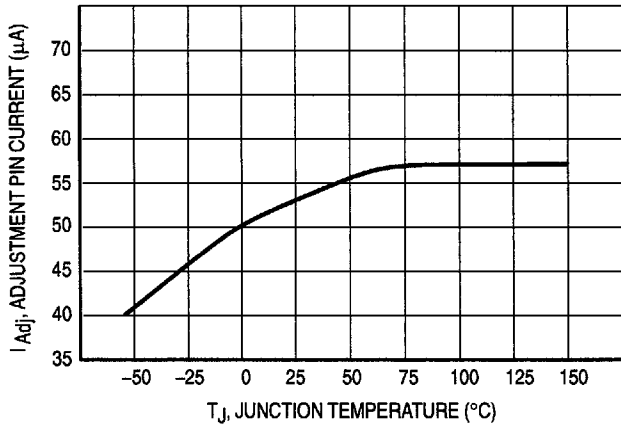

Figure 8. Dropout Voltage

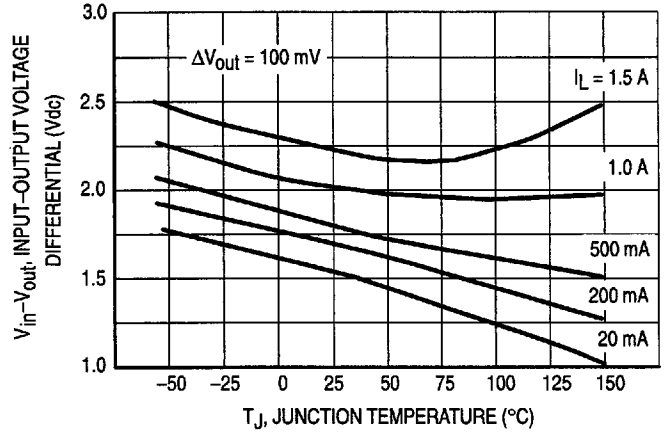

Figure 9. Temperature Stability

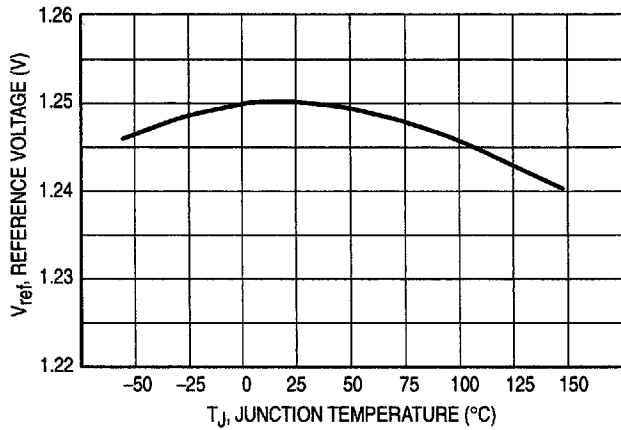

Figure 10. Minimum Operating Current

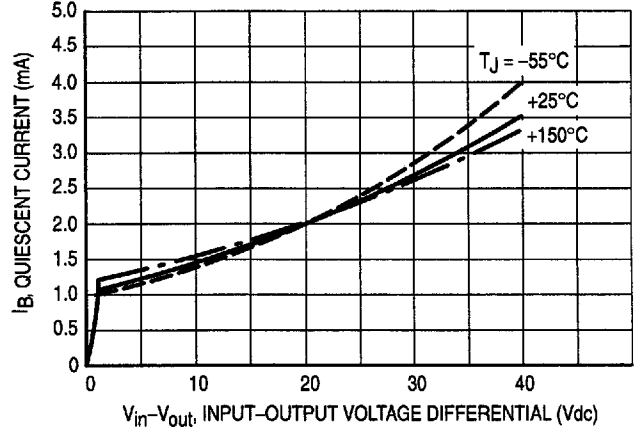

Figure 11. Ripple Rejection versus Output Voltage

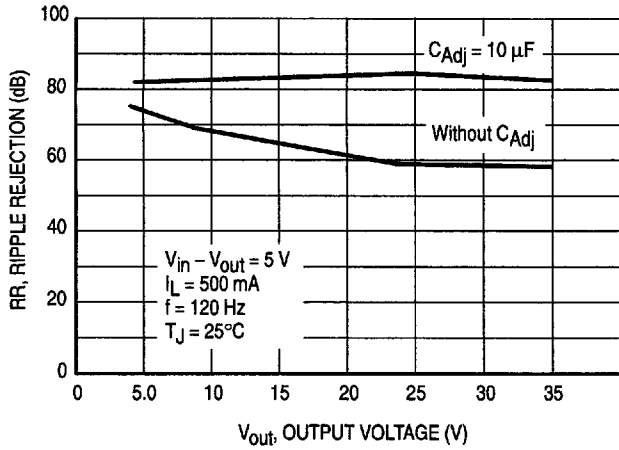

Figure 12. Ripple Rejection versus Output Current

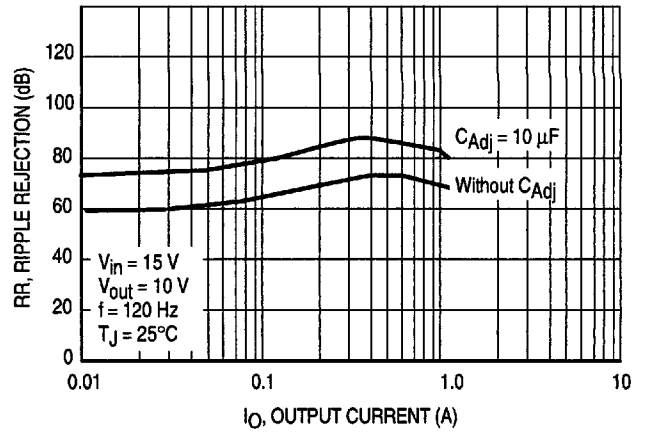

Figure 13. Ripple Rejection versus Frequency

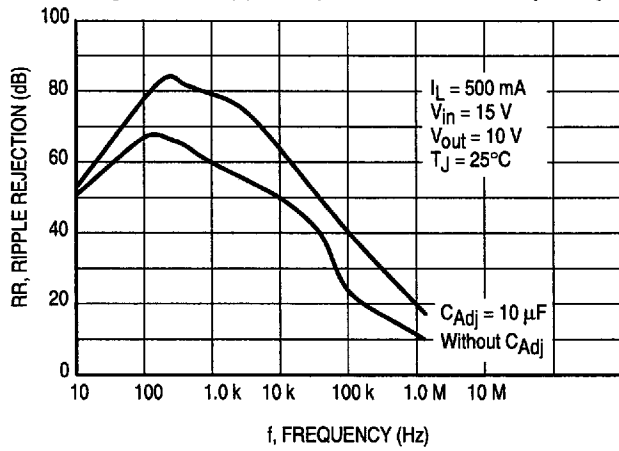

Figure 14. Output Impedance

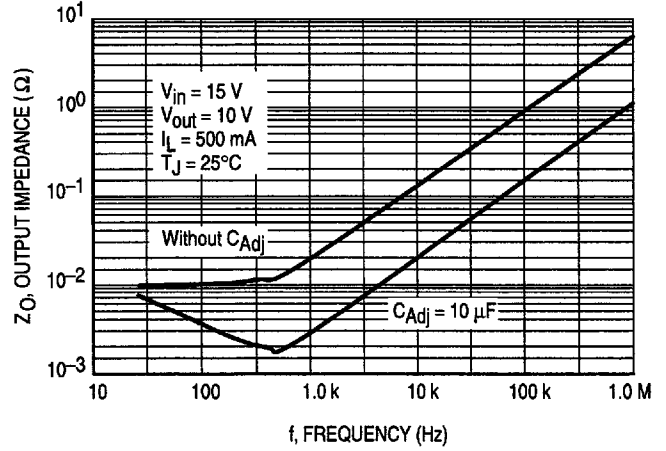

Figure 15. Line Transient Response

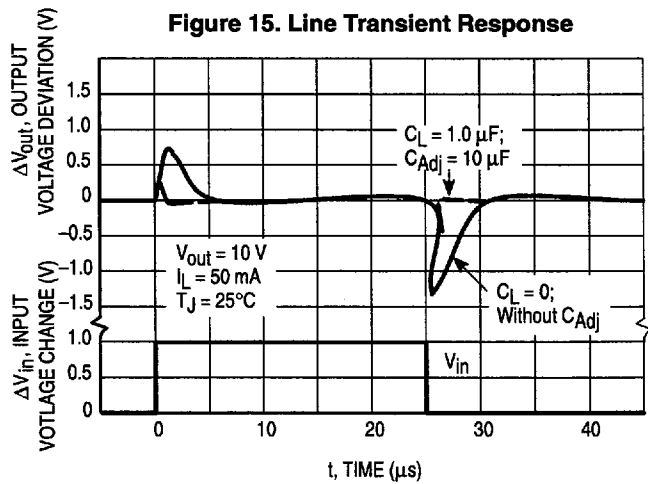
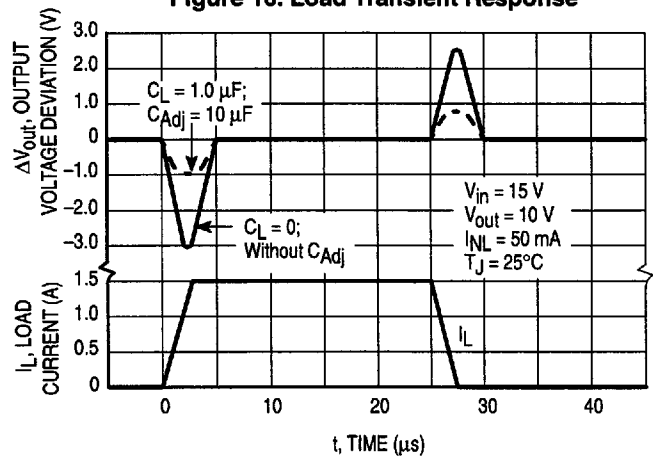

Figure 16. Load Transient Response



APPLICATIONS INFORMATION

Basic Circuit Operation

The LM317 is a 3-terminal floating regulator. In operation, the LM317 develops and maintains a nominal 1.25 V reference ( $V_{ref}$ ) between its output and adjustment terminals. This reference voltage is converted to a programming current ( $I_{prog}$ ) by  $R_1$  (see Figure 17), and this constant current flows through  $R_2$  to ground.

The regulated output voltage is given by:

$$V_{out} = V_{ref} \left( 1 + \frac{R_2}{R_1} \right) + I_{Adj} R_2$$

Since the current from the adjustment terminal ( $I_{Adj}$ ) represents an error term in the equation, the LM317 was designed to control  $I_{Adj}$  to less than 100  $\mu A$  and keep it constant. To do this, all quiescent operating current is returned to the output terminal. This imposes the requirement for a minimum load current. If the load current is less than this minimum, the output voltage will rise.

Since the LM317 is a floating regulator, it is only the voltage differential across the circuit which is important to performance, and operation at high voltages with respect to ground is possible.

Figure 17. Basic Circuit Configuration

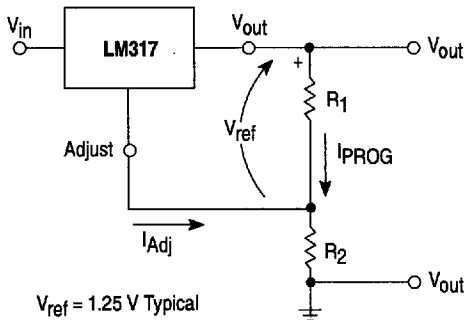

Load Regulation

The LM317 is capable of providing extremely good load regulation, but a few precautions are needed to obtain maximum performance. For best performance, the programming resistor ( $R_1$ ) should be connected as close to the regulator as possible to minimize line drops which effectively appear in series with the reference, thereby degrading regulation. The ground end of  $R_2$  can be returned near the load ground to provide remote ground sensing and improve load regulation.

External Capacitors

A 0.1  $\mu F$  disc or 1.0  $\mu F$  tantalum input bypass capacitor ( $C_{in}$ ) is recommended to reduce the sensitivity to input line impedance.

The adjustment terminal may be bypassed to ground to improve ripple rejection. This capacitor ( $C_{Adj}$ ) prevents ripple from being amplified as the output voltage is increased. A 10  $\mu F$  capacitor should improve ripple rejection about 15 dB at 120 Hz in a 10 V application.

Although the LM317 is stable with no output capacitance, like any feedback circuit, certain values of external capacitance can cause excessive ringing. An output capacitance ( $C_O$ ) in the form of a 1.0  $\mu F$  tantalum or 25  $\mu F$  aluminum electrolytic capacitor on the output swamps this effect and insures stability.

Protection Diodes

When external capacitors are used with any IC regulator it is sometimes necessary to add protection diodes to prevent the capacitors from discharging through low current points into the regulator.

Figure 18 shows the LM317 with the recommended protection diodes for output voltages in excess of 25 V or high capacitance values ( $C_O > 25 \mu F$ ,  $C_{Adj} > 10 \mu F$ ). Diode  $D_1$  prevents  $C_O$  from discharging thru the IC during an input short circuit. Diode  $D_2$  protects against capacitor  $C_{Adj}$  discharging through the IC during an output short circuit. The combination of diodes  $D_1$  and  $D_2$  prevents  $C_{Adj}$  from discharging through the IC during an input short circuit.

Figure 18. Voltage Regulator with Protection Diodes

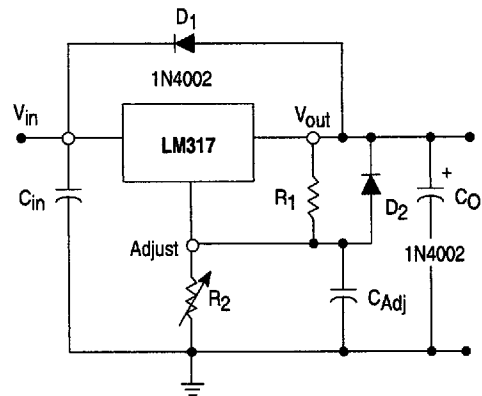
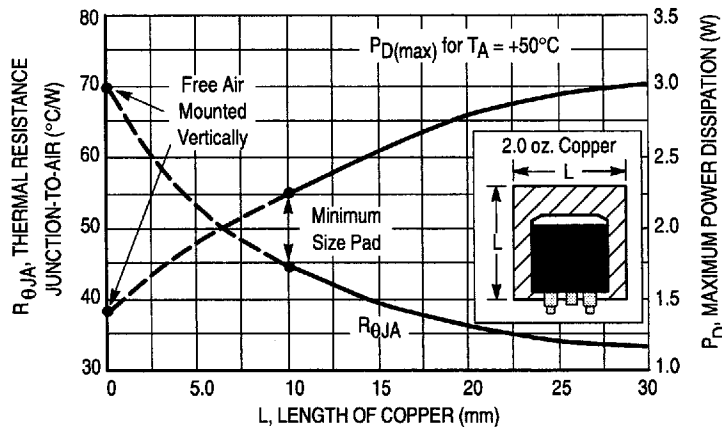
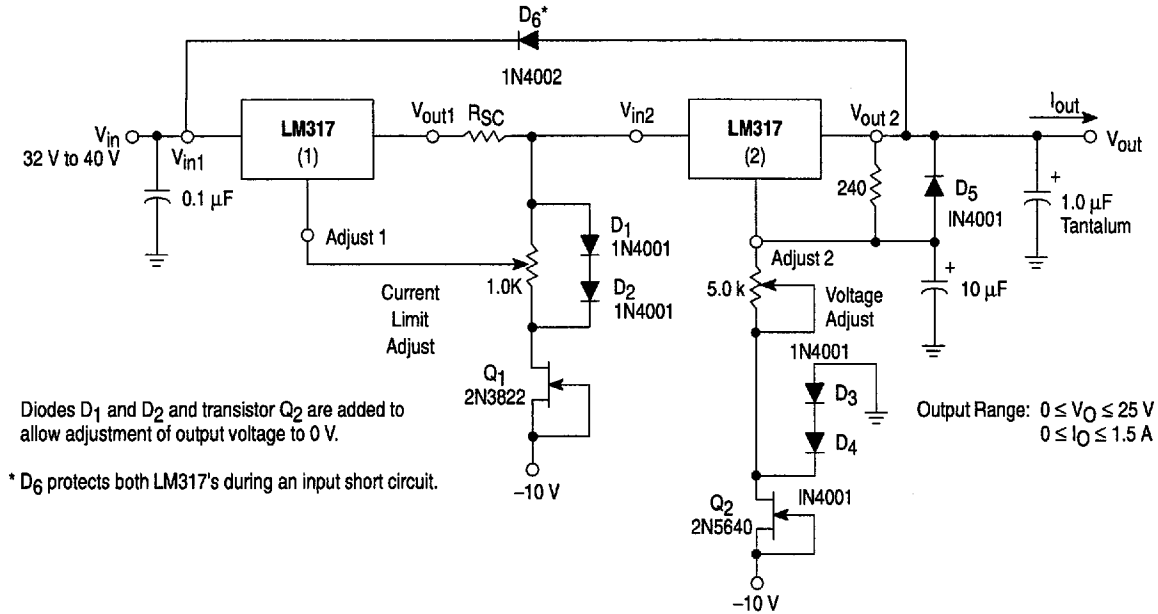

Figure 19. D<sup>2</sup>PAK Thermal Resistance and Maximum Power Dissipation versus P.C.B. Copper Length



# LM317

**Figure 20. "Laboratory" Power Supply with Adjustable Current Limit and Output Voltage**



**Figure 21. Adjustable Current Limiter**

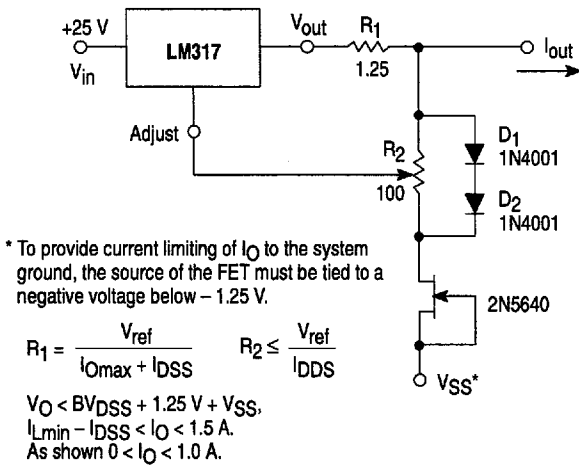

**Figure 22. 5.0 V Electronic Shutdown Regulator**

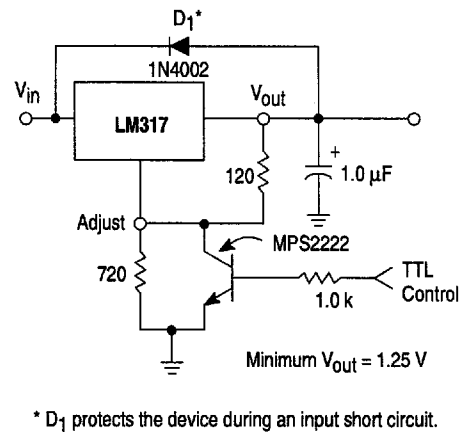

**Figure 23. Slow Turn-On Regulator**

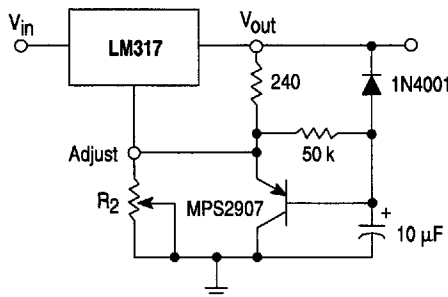

**Figure 24. Current Regulator**

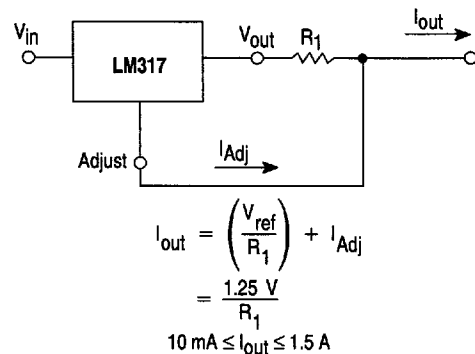



# LM317

## OUTLINE DIMENSIONS

### T SUFFIX PLASTIC PACKAGE CASE 221A-06 ISSUE Y

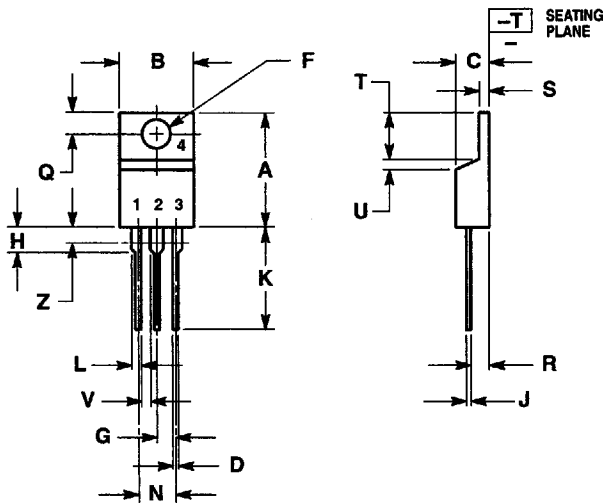

- NOTES:
1. DIMENSIONING AND TOLERANCING PER ANSI Y14.5M, 1982.
  2. CONTROLLING DIMENSION: INCH.
  3. DIM Z DEFINES A ZONE WHERE ALL BODY AND LEAD IRREGULARITIES ARE ALLOWED.

DIM	INCHES		MILLIMETERS	
	MIN	MAX	MIN	MAX
A	0.570	0.620	14.48	15.75
B	0.380	0.405	9.66	10.28
C	0.160	0.190	4.07	4.82
D	0.025	0.035	0.64	0.88
F	0.142	0.147	3.61	3.73
G	0.095	0.105	2.42	2.66
H	0.110	0.155	2.80	3.93
J	0.018	0.025	0.46	0.64
K	0.500	0.562	12.70	14.27
L	0.045	0.060	1.15	1.52
N	0.190	0.210	4.83	5.33
Q	0.100	0.120	2.54	3.04
R	0.080	0.110	2.04	2.79
S	0.045	0.055	1.15	1.39
T	0.235	0.255	5.97	6.47
U	0.000	0.050	0.00	1.27
V	0.045	-	1.15	-
Z	-	0.080	-	2.04

### D2T SUFFIX PLASTIC PACKAGE CASE 936-03 (D<sup>2</sup>PAK) ISSUE B

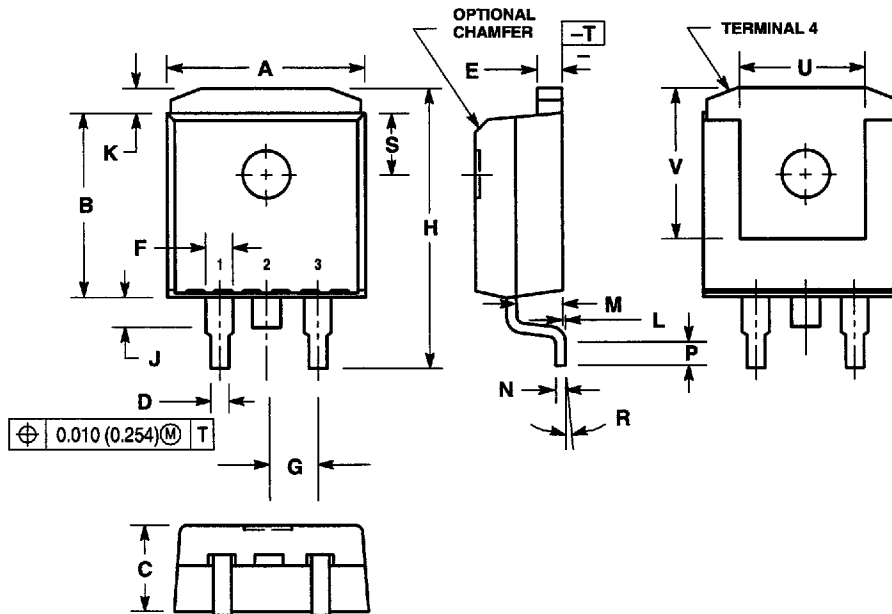

- NOTES:
1. DIMENSIONING AND TOLERANCING PER ANSI Y14.5M, 1982.
  2. CONTROLLING DIMENSION: INCH.
  3. TAB CONTOUR OPTIONAL WITHIN DIMENSIONS A AND K.
  4. DIMENSIONS U AND V ESTABLISH A MINIMUM MOUNTING SURFACE FOR TERMINAL 4.
  5. DIMENSIONS A AND B DO NOT INCLUDE MOLD FLASH OR GATE PROTRUSIONS. MOLD FLASH AND GATE PROTRUSIONS NOT TO EXCEED 0.025 (0.635) MAXIMUM.

DIM	INCHES		MILLIMETERS	
	MIN	MAX	MIN	MAX
A	0.386	0.403	9.804	10.236
B	0.396	0.368	9.042	9.347
C	0.170	0.180	4.318	4.572
D	0.026	0.036	0.660	0.914
E	0.045	0.055	1.143	1.397
F	0.051 REF		1.295 REF	
G	0.100 BSC		2.540 BSC	
H	0.539	0.579	13.691	14.707
J	0.125 MAX		3.175 MAX	
K	0.050 REF		1.270 REF	
L	0.000	0.010	0.000	0.254
M	0.088	0.102	2.235	2.591
N	0.018	0.026	0.457	0.660
P	0.058	0.078	1.473	1.981
R	5° REF		5° REF	
S	0.116 REF		2.946 REF	
U	0.200 MIN		5.080 MIN	
V	0.250 MIN		6.350 MIN	