

NEW

SMD Choke Coils

Singapore

Series: **Magnetic shielded type**

Type: **ELL6□H**

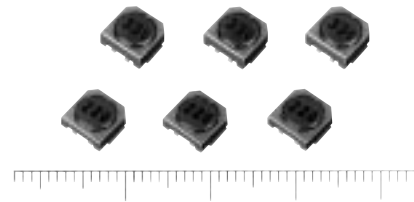

SMD type choke coils (2.5 mm, 3.0 mm)

ELL 6□H
Type

■ **Features**

- Thin type (height 2.5 mm, 3.0 mm)
- Higher reliability in mounting by separated user terminal and internal connection.
- Capable of corresponding big current

■ **Recommended Applications**

- Videos, Audio, Mobile communications, Electric battery driving equipment
- Choke coils for Chopper circuit decoupling choked in DC/DC convertor circuit

■ **Cautions for Use**

Convertor electric power of DC/DC convertor

- Chopper type : 1 W max.
- Operating temperature
- 105 °C max. (Including self-temperature rise)

■ **Explanation of Part Numbers**

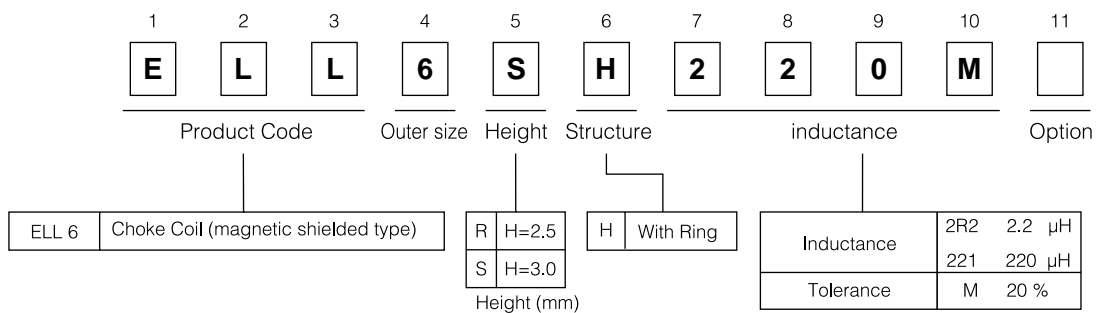

■ Dimensions in mm (not to scale)

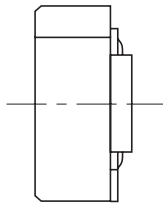
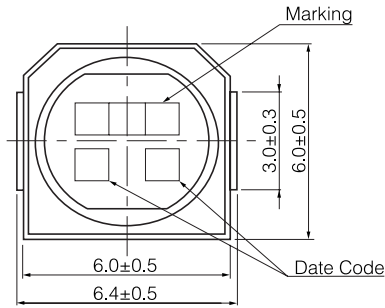

■ Connections (Top view)

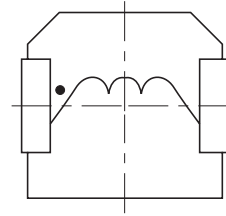

■ Recommended land patterns in mm (not to scale)

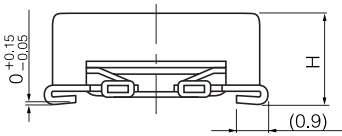

Type	Height
ELL6RH	2.5±0.3 mm
ELL6SH	3.0±0.3 mm

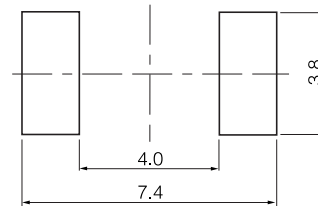

■ Characteristics (Reference)

Inductance at 100 kHz Tol. ± 20 %	DCR		Current (max.)		Marking
	at 20 °C Tol. ± 20 %		ELL6RH H=2.5 mm	ELL6SH H=3.0 mm	
1.0 μH	ELL6RH H=2.5 mm 0.019 Ω	ELL6SH H=3.0 mm 0.019 Ω	ELL6RH H=2.5 mm 3000 mA	ELL6SH H=3.0 mm 3400 mA	1R0
1.5	0.024	0.024	2400	3200	1R5
2.7	0.039	0.031	1800	2400	2R7
3.3	0.044	0.034	1600	2200	3R3
4.7	—	0.042	—	2000	4R7
5.1	0.056	—	1550	—	5R1
5.6	—	0.049	—	1800	5R6
6.2	0.062	—	1400	—	6R2
6.8	—	0.052	—	1500	6R8
7.5	0.080	—	1250	—	7R5
8.2	0.087	0.061	1200	1400	8R2
10	0.095	0.065	1100	1300	100
12	0.13	0.071	1000	1200	120
15	0.15	0.096	850	1100	150
18	0.17	0.11	800	1000	180
22	0.22	0.14	700	900	220
27	0.26	0.16	650	800	270
33	0.38	0.18	600	700	330
39	0.41	0.24	550	650	390
47	0.48	0.27	500	600	470
56	0.54	0.29	450	550	560
68	0.77	0.52	400	500	680
82	0.87	0.60	350	450	820
100	1.00	0.68	300	400	101
120	1.50	0.75	280	370	121
150	1.80	0.86	250	350	151
180	2.00	1.20	230	300	181

* Current: This indicates the value of current when the inductance is 80% more than nominal value and temperature rising Δt=45 °C lower at D.C superposition. (at 20 °C)