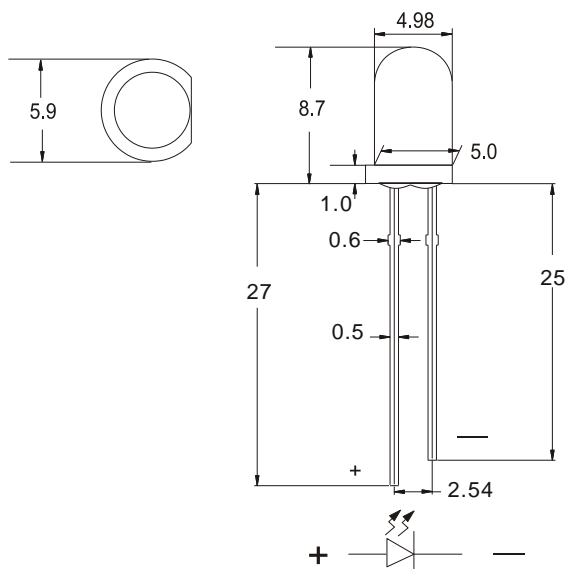

Part No.	5G4VC-E15W505	Spec No.		Page	1 of 3
----------	---------------	----------	--	------	--------

Features

- ◆ Standard 5mm diameter package
- ◆ Wide viewing angle
- ◆ General purpose leads
- ◆ Reliable and rugged

Package Dimension:

NOTE:TOLERANCE $\pm 0.5\text{mm}$

Part NO.	Lens Color	Source Color
5G4VC-E15W505	Water Clear	Bluish-green

Notes:

1. All dimensions are in millimeters (inches).
2. Tolerance is $\pm 0.25(.10)$ mm unless otherwise noted.
3. Protruded resin under flange is 1.0mm(.04") max.
4. Lead spacing is measure where the leads emerge from the package.
5. Specifications are subject to change without notice.
6. Caution in ESD:

Static Electricity and surge damages the LED. It is recommended to use a wrist band or anti-electrostatic glove when handling the LED. All devices, equipment and machinery must be properly grounded.

Part No.	5G4VC-E15W505	Spec No.		Page	1 of 3
----------	---------------	----------	--	------	--------

Absolute Maximum Ratings at Ta=25°C

Parameter	MAX.	Unit
Power Dissipation	100	mW
Peak Forward Current (1/10 Duty Cycle, 0.1ms Pulse Width)	100	mA
Continuous Forward Current	30	mA
Derating Linear From 50°C	0.4	mA/°C
Reverse Voltage	5	V
Operating Temperature Range	-40°C to +80°C	
Storage Temperature Range	-40°C to +80°C	
Lead Soldering Temperature [4mm(.157") From Body]	260°C for 5 Seconds	

Electrical Optical Characteristics: at Ta=25°C

Parameter	Symbol	Min.	Typ.	Max.	Unit	Test Condition
Luminous Intensity	I_v	15000		18000	mcd	$I_F=20\text{mA}$ (Note 1)
Viewing Angle	$2\theta_{1/2}$	---	15	---	Deg	(Note 2)
Peak Emission Wavelength	λ_p	500	505	---	nm	$I_F=20\text{mA}$
Dominant Wavelength	λ_d	---	505	---	nm	$I_F=20\text{mA}$ (Note 3)
Spectral Line Half-Width	$\Delta\lambda$	---	30	---	nm	$I_F=20\text{mA}$
Forward Voltage	V_F	3.0	3.2	3.5	V	$I_F=20\text{mA}$
Reverse Current	I_R	---	---	10	μA	$V_R=5\text{V}$

Notes:

- Luminous intensity is measured with a light sensor and filter combination that approximates the CIE eye-response curve.
- $\theta_{1/2}$ is the off-axis angle at which the luminous intensity is half the axial luminous intensity.
- The dominant wavelength (λ_d) is derived from the CIE chromaticity diagram and represents the single wavelength, which defines the color of the device.

Part No.	5G4VC-E15W505	Spec No.		Page	2 of 3
----------	---------------	----------	--	------	--------

**Typical Electrical/Optical Characteristics Curves
(25°C Ambient Temperature Unless Otherwise Noted)**

Spectral Radiance Peak 505

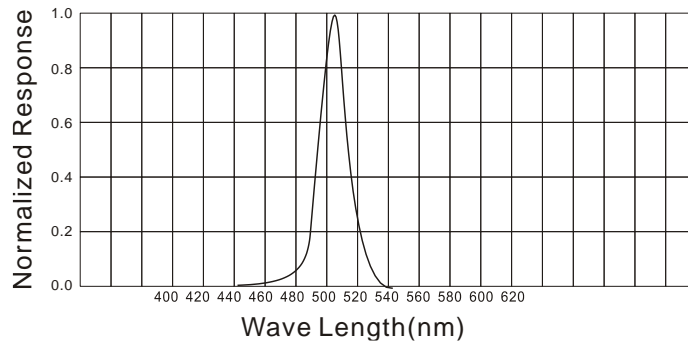

Forward Current vs Forward Voltage

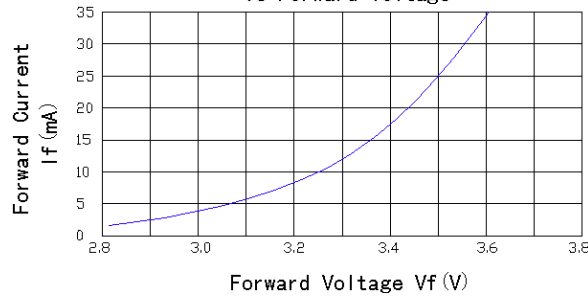

Relative Luminous Intensity vs Forward Current

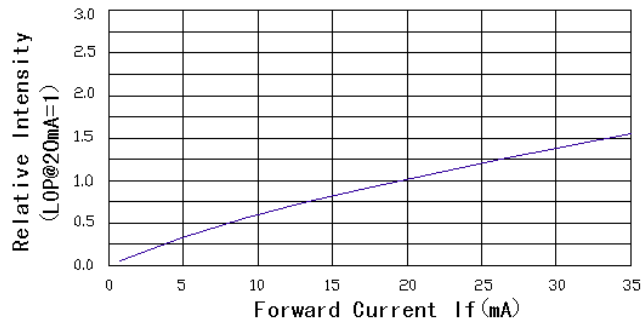

Beam Patter

