

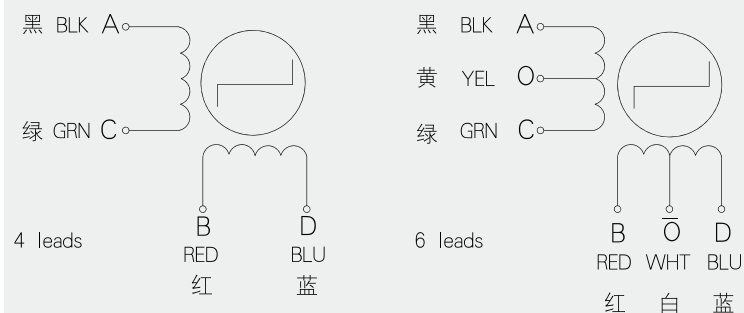

接线图 Wiring Diagram

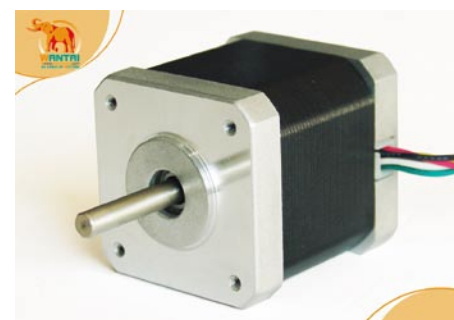

混合式步进电机
HYBRID STEPPING MOTOR
42BYGHM系列 (Nema17 Series)



技术数据 Electrical Specifications

电机型号 Model	步距角 Step Angle (°)	机身長 Motor Length L(mm)	相电压 Rated Voltage (V)	相电流 Rated Current (A)	相电阻 Phase Resistance (Ω)	相电感 Phase Inductance (mH)	静力矩 Holding Torque (g.cm)	引线数 Lead Wires (NO.)	转动惯量 Rotor Inertia (g.cm ²)	定位力矩 Detent Torque (g.cm)	重量 Motor Weight (kg)
42BYGHM201	0.9	34	5	0.4	12.5	21	1600	4	34	180	0.2
42BYGHM206	0.9	34	3.6	1.0	3.6	3.3	1400	6	34	180	0.2
42BYGHM208	0.9	34	2.5	1.2	2.1	5	2100	4	34	180	0.2
42BYGHM602	0.9	40	11.2	0.4	28	30	2600	6	54	220	0.26
42BYGHM604	0.9	40	3.6	1.2	3.0	3.5	2600	6	54	220	0.26
42BYGHM607	0.9	40	2.6	1.7	1.5	3.2	3200	4	54	220	0.26
42BYGHM805	0.9	48	3.5	1	3.5	7.6	3700	4	68	260	0.36
42BYGHM809	0.9	48	2.7	1.68	1.6	3.5	4200	4	68	260	0.36
42BYGHM810	0.9	48	2.4	2.4	1	1.8	4800	4	68	260	0.36

* 以上仅为代表性产品,派生产品可根据客户要求制作。 We can manufacture products according to customer's requirement.

外型图 Mechanical Dimensions

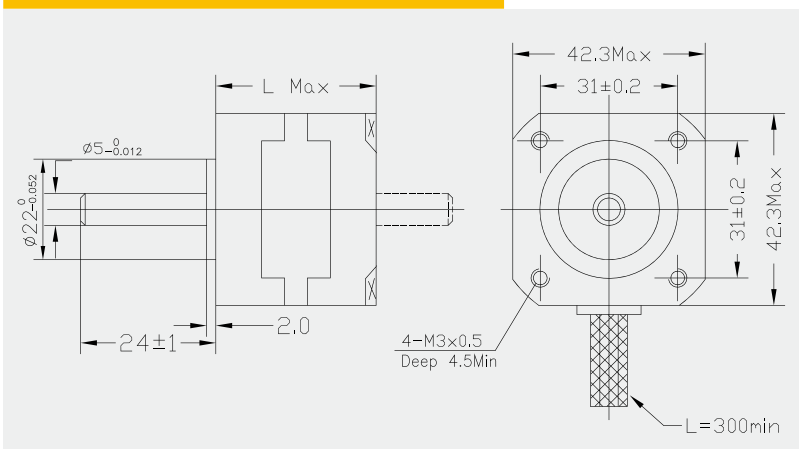

机身说明 Motor Length

电机型号	机身長
42BYGHM2XX	34mm
42BYGHM6XX	40mm
42BYGHM8XX	48mm

接线图 Wiring Diagram

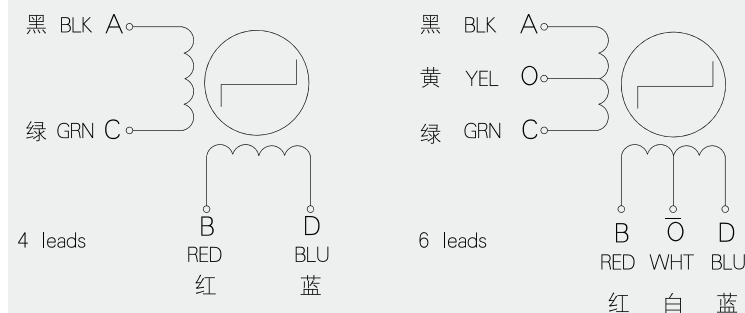

混合式步进电机
HYBRID STEPPING MOTOR
42BYGHW系列 (Nema17 Series)

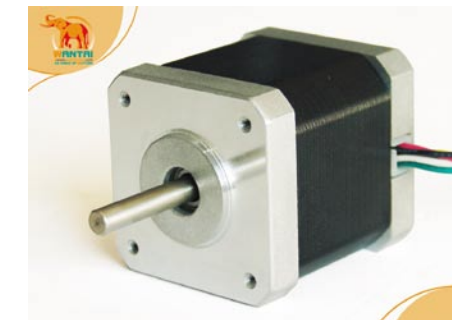

技术数据 Electrical Specifications

电机型号 Model	步距角 Step Angle (°)	机身長 Motor Length L(mm)	相电压 Rated Voltage (V)	相电流 Rated Current (A)	相电阻 Phase Resistance (Ω)	相电感 Phase Inductance (mH)	静力矩 Holding Torque (g.cm)	引线数 Lead Wires (NO.)	转动惯量 Rotor Inertia (g.cm ²)	定位力矩 Detent Torque (g.cm)	重量 Motor Weight (kg)
42BYGHW205	1.8	34	12	0.3	40	18	1200	6	34	200	0.2
42BYGHW208	1.8	34	12	0.4	30	37	2600	4	34	200	0.2
42BYGHW213	1.8	34	12	0.6	20	15	2000	6	34	200	0.2
42BYGHW602	1.8	40	12	0.4	30	21	2500	6	54	220	0.26
42BYGHW603	1.8	40	12	0.4	30	40	3800	4	54	220	0.26
42BYGHW607	1.8	40	3.6	1.2	3	3.2	2600	6	54	220	0.26
42BYGHW609	1.8	40	2.55	1.7	1.5	3	4000	4	54	220	0.26
42BYGHW801	1.8	48	12	0.4	30	25	3200	6	68	280	0.36
42BYGHW804	1.8	48	3.6	1.2	3	5	4500	4	68	280	0.36
42BYGHW811	1.8	48	3.1	2.3	1.25	1.8	4800	4	68	280	0.36

* 以上仅为代表性产品,派生产品可根据客户要求制作。 We can manufacture products according to customer's requirement.

外型图 Mechanical Dimensions

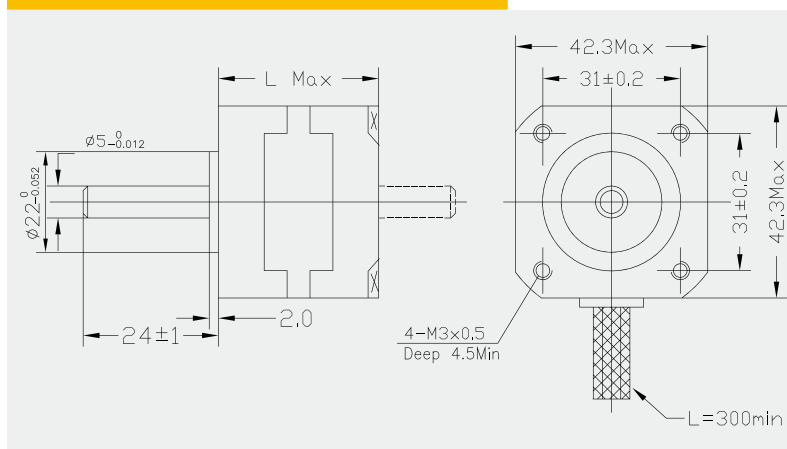

机身说明 Motor Length

电机型号	机身長
42BYGHW2XX	34mm
42BYGHW6XX	40mm
42BYGHW8XX	48mm