

Datasheet

Steel E Type Circlip, 6mm Shaft Diameter, 4mm Groove Diameter

RS Stock number 289-477



STANDARD SERIES 'E' CIRCLIPS **INCORPORATING**
D1500 INCORPORATING DIN 6799 & BS 3673/2 Metric Series **& N1500** BS 3673 Part 2 and MIL-R-21248/MS 16633

All dimensions in mm

Standard material - carbon spring steel.
 Standard finish - phosphate and oil.

Sizes printed in blue are preferred sizes

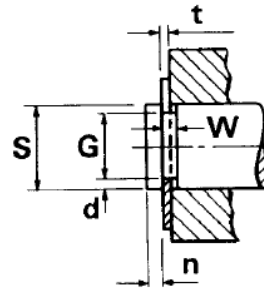
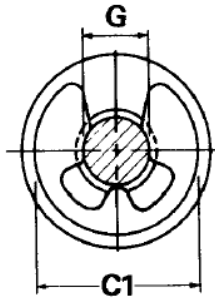
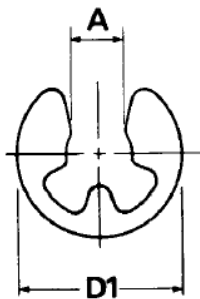

Circlip in groove

† Thrust load calculations see pages 9 & 10

D1500 *This size in Beryllium copper only

SIZE CODE	B.S. Ref	Shaft (S)		Groove (G)				Circlip (F)					Tc† (N)	Tg† (N)	Applicator	BASE			
		S.	Tol.	G.	Tol.	W.	Tol.	n (min)	d Nom	t	Tol.	D1					C1	A	Tol.
*0008	008MS	1.20	±0.20	0.8	+0.00	0.24	+0.04	0.4	0.20	0.20	±0.02	1.95	2.25	0.58	±0.04	63	30	—	—
0012	012MS	1.70	±0.30	1.2	-0.04	0.34	-0.00	0.6	0.25	0.30		2.90	3.25	1.01		203	53	28	DR 1.2
0015	015MS	2.25	±0.25	1.5	+0.00	0.44	-0.06	0.8	0.38	0.40		3.85	4.25	1.28		358	105	21A	DR 1.5
0019	019MS	2.75		1.9	0.54	1.0		0.43	0.50	4.40		4.8	1.61	546		145	22	DR 1.9	
0023	023MS	3.50		2.3	0.64	1.0		0.60	0.60	5.90		6.3	1.94	835		260	3C	DR 2.3	
0032	032MS	4.50	±0.50	3.2	+0.00	0.64	+0.05	1.0	0.65	0.60	6.80	7.3	2.70	±0.048	1070	365	AM9	DR 3.2	
0040	040MS	6.00		4.0		0.74		1.2	1.00	0.70	8.80	9.3	3.34		1670	745	23B	DR 4	
0050	050MS	7.00	±1.00	5.0	-0.075	0.74	-0.00	1.2	1.00	0.70	10.75	11.3	4.11	±0.058	1950	870	7B	DR 5	
0060	060MS	8.00		6.0		0.74		1.2	1.00	0.70	11.75	12.3	5.26		2220	995	24	DR 6	
0070	070MS	9.50		7.0		0.94		1.5	1.25	0.90	13.80	14.3	5.84		3400	1480	15	FR 7	
0090	090MS	10.50	±1.50	8.0	+0.00	1.05	-0.09	1.8	1.25	1.00	15.60	16.3	6.52	±0.058	4170	1630	AM20	FR 8	
0090	090MS	12.00		9.0		1.15		2.0	1.50	1.10	18.20	18.8	7.63		5250	2240	25	FR 9	
0100	100MS	13.00	±2.00	10.0	+0.00	1.25	+0.08	2.0	1.50	1.20	19.65	20.4	8.32	±0.07	6200	2430	26	FR 10	
0120	120MS	15.50		12.0		1.35		2.5	1.75	1.30	22.65	23.4	10.45		8010	3370	27	FR 12	
0150	150MS	20.00		15.0		1.55		3.0	2.50	1.50	28.60	29.4	12.61		11900	6220	20B	FR 15	
0190	190MS	25.50	±5.50	19.0	+0.00	1.85	-0.00	3.5	3.25	1.75	36.70	37.6	15.92	±0.084	17700	10300	32A	FR 19	
0240	240MS	31.50		24.0		2.05		4.0	3.75	2.00	43.65	44.6	21.88		25000	14700	—	—	

All dimensions in inches

Standard material - carbon spring steel.
Standard finish - phosphate and oil.

Sizes printed in blue are preferred sizes

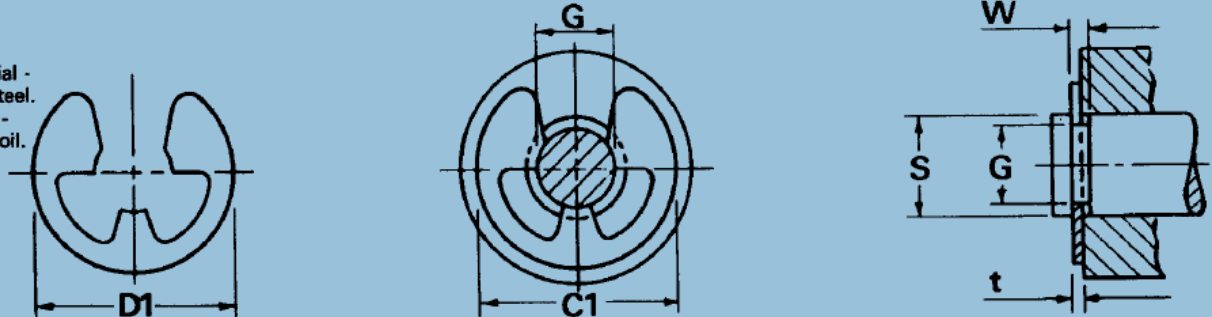

N1500

*This size in Beryllium copper only

† Thrust load calculations see pages 9 & 10

SIZE CODE	B.S. Ref.	Shaft (S)		Groove (G)				Circlip (F)				Tc† (lb.f)	Tg† (lb.f)	Applicator	Base	SIZE CODE
		S	Tol.	G	Tol.	W	Tol.	D1	C1	t	Tol.					
*X004	028PS	.040	+ .010 - .000	.026	+ .002 - .000	.012	+ .002 - .000	.079	.090	.010	± .001	15	5	—	—	X004
X006	—	.062		.052		.012		.140	.150	.010		36	6	AM2	SF2	X006
0006	054PS	.062		.052		.012		.156	.165	.010		36	6	AM3	SF3	0006
Y006	—	.062	+ .030	.052		.023		.187	.200	.020		72	6	—	—	Y006
X009	—	.094	- .000	.074		.018		.230	.245	.015		81	17	AM7	SF4	X009
0009	076PS	.094		.074		.018		.187	.200	.015		81	17	AM5	SF5	0009
X011	081A2	.110		.079		.018		.375	.390	.015		95	32	AM6	SF6	X011
0012	097PS	.125		.095		.018		.230	.240	.015		108	35	AM7	SF7	0012
X014	104PS	.140	+ .040	.102		.018		.203	.214	.015		121	50	AM8	SF8	X014
Y014	112A1	.140	- .000	.110		.018		.250	.265	.015		121	39	AM10	SF10	Y014
0014	107A1	.140		.105	+ .003 - .000	.029	+ .003 - .000	.270	.285	.025	± .002	202	46	AM9	SF9	0014
0015	118A1	.156	+ .050 - .000	.116		.029		.282	.295	.025		225	58	AM11	SF11	0015
X017	129PS	.172		.127		.029		.312	.325	.025		248	72	AM12	SF12	X017
X018	—	.188		.125		.029		.375	.390	.025		271	110	AM13	SF13	X018
0018	149PS	.188	+ .060 - .000	.147		.029		.335	.350	.025		271	72	AM14	SF14	0018
X021	190PS	.219		.188		.029		.437	.450	.025		316	63	AM15	SF15	X021
0025	212PS	.250		.210		.029		.527	.540	.025		361	93	AM16	SF16	0025
X031	252PS	.312	+ .100	.250		.029		.500	.520	.025		450	180	AM16	SF17	X031
0037	306PS	.375	- .000	.303		.039		.660	.680	.035		757	252	AM18	SF18	0037
0043	346PS	.438		.343		.039		.687	.710	.035		885	388	AM19	SF19	0043
X043	383A1	.438		.380	+ .003 - .000	.039	+ .003 - .000	.600	.620	.035	± .003	884	237	AM20	SF20	X043
0050	399PS	.500		.396		.046		.800	.820	.042		1210	485	AM21	SF21	0050
0062	488PS	.625		.485		.046		.940	.960	.042		1510	816	AM22	SF22	0062
X074	628A1	.744	+ .120	.625		.056		1.000	1.020	.050		2160	1190	AM23	SF23	X074
0075	583PS	.750	- .000	.580		.056		1.120	1.140	.050		2520	1630	AM24	SF24	0075
0087	678PS	.875		.675		.056		1.300	1.320	.050		2840	1370	AM25	SF25	0087
X098	—	.984		.835	.056	1.500	1.530	.050	4250	1210	AM26	SF26	X098			
X118	—	1.188	+ .200	1.079	.068	1.626	1.670	.062	4920	1860	AM27	SF27	X118			
X137	—	1.375	- .000	1.230	.068	1.875	1.920	.062	4920	1860	—	—	X137			