

深圳市鸿泰电机有限公司

PRODUCT SPECIFICATION

产品规格书

CUSTOMER 客户名

称 :

PRODUCT NAME

产品名称:

AC BRUSHLESS FAN

DIMENSIONS 产

品尺寸:

200mm*200mm*60mm

MODEL

产品型号 :

HT20060HA2BL

DATE

发布日期 :

Checked 审核	Prepared 制作
Customer Approve 客户核准	

1. Scope of application:

This product specification specifies the performance and test methods of the product as the basis for technical confirmation

2. General characteristics

2.1 Product application scope

The product is mainly used in ground automatic control device, electronic equipment, medical equipment, computer, power equipment, welding machine, packaging and printing equipment, satellite communication, CNC machinery and other automatic equipment ventilation and heat dissipation.

2.2 Standard test conditions:

Under normal circumstances, the test is carried out under the conditions of standard atmospheric pressure, temperature of 5 ~ 35°C and relative humidity of less than 85%.

The standard test conditions of this specification are standard atmospheric pressure, temperature 25°C, relative humidity less than 60%;

2.3 By Standard

GB12350-2009 Safety requirements for small power motors

CNCA-01C-013:2007 Rules for the Implementation of Mandatory Certification of Electrical and Electronic Products (Small power Motors)

3. Product structure

The product is composed of cylindrical aluminum alloy frame, PBT plastic wind blade and motor. It is installed through double-sided flange, small size, maintenance-free, easy installation and other characteristics, and has low noise, low vibration, reliable operation and other excellent performance.

4、General

characteristic

序号	item	standard values	Unit	Note
1	Product model	AC20060HBL	square	
2	Apparent dimension	200*200*60	mm	
3	Rated voltage	AC220V/240	V	
4	Starting voltage	AC187	V	
5	frequency	50/60	Hz	
6	Rated current	0.4+-5%	A	
7	power	65+-5%	W	
8	Rotational speed	2650+-5%	RPM	
9	Air volume	450	CFM	
10	Wind speed		m/s	
11	Temperature rise	60	°C	
12	Noise level	65	dba	
13	linker	UL1015#18AWG	mm	
14	Use environment	40	°C	
15	Unit weight	1.5	KG	
16	package	10	set	Paper packaging

Main material specification details

Item	Part name	Material	safety grade	safety code	material manufacturer
1	Outer frame	ADC12			
2	vallum	PBT-PV33%			New style fan blade
3	Fixed rotor	1000			
4	Copper wire	QA-1			
5	bearing	ball bearing			

5、产品图纸：

MATERIAL

1. FRAME: ALuminum die-cast, Black color
2. IMPELLER: THERMOLASTIC PBT OF UL 94V0
3. LEAD WIRE: UL 1015# 18 AWG

DIMENSIONS:MM

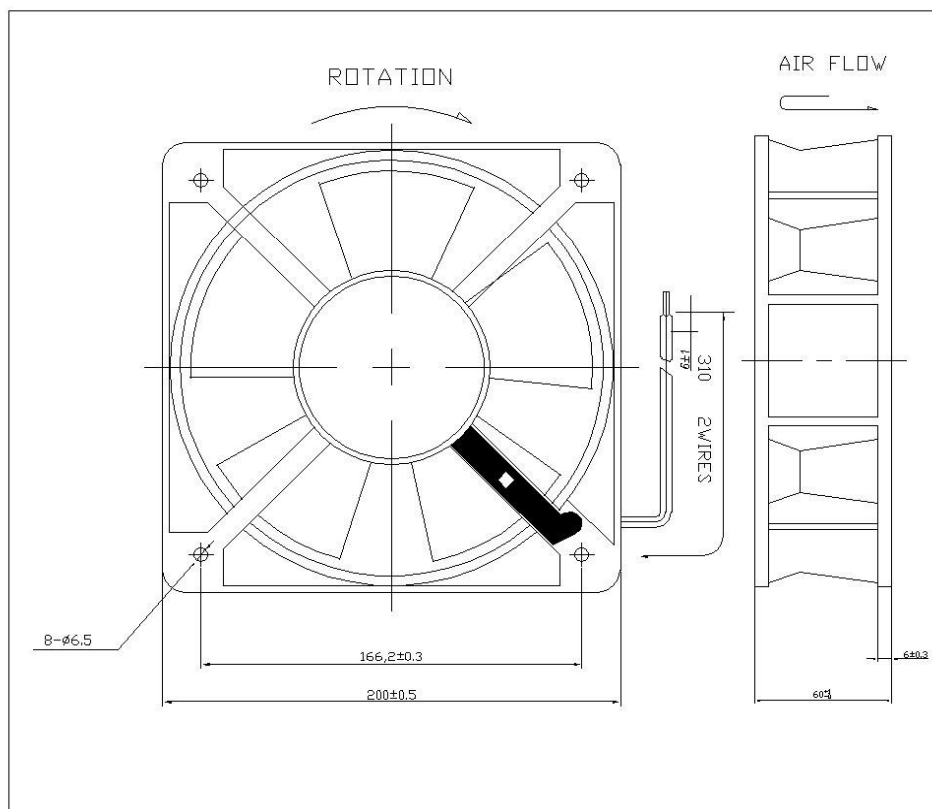

	SPEC. NO		REVISE DATE	
	ISSUE DATE		EDITION	
	PAGE			

6、Packing method: (foam packing)

