

**CE IP67****■ Features**

- Series connection style
- Line to Ground & Line to Line protected
- 10kA maximum discharge current(I_{max}), 8/20 μ s
- Thermally protected
- Double insulation cable wire
- LED status indicator
- IP67 design for indoor or outdoor installations
- Suitable for LED driver surge protection with class I insulation

■ Applications

- Outdoor and commercial LED Lighting
- Roadway lighting
- Traffic lighting
- Digital signage
- Wall wash lighting
- Parking garage/lot lighting
- Flood lighting
- Tunnel lighting
- Street lighting

■ Description

The SPD-10-320S LED Power Supply SPD is mainly composed of MOV, GDT and flame-retardant shell. It has protective functions of surge, overflowing, thermal(thermal fusing)and flame retardant, used for the power supply protection of LED road lamp.

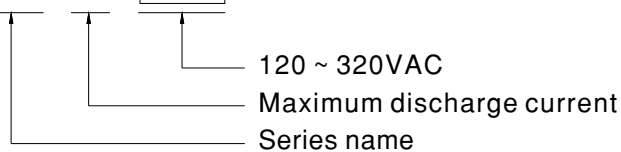
■ Model Encoding**SPD - 10 - 320S**

SPECIFICATION

MODEL	SPD-10-320S
OPERATING VOLTAGE	120 ~ 320VAC 50/60Hz
MCOV/U_c (MAX. CONTINUOUS OPERATING VOLTAGE) <small>Note.1</small>	320VAC
CONTINUOUS CURRENT (max.)	5A
U_p (VOLTAGE PROTECTION LEVEL) <small>Note.2</small>	L-N: 1200V L-G/PE: 1500V N-G/PE: 1500V
I_n (NOMINAL DISCHARGE CURRENT) <small>Note.3</small>	5kA, 8/20μs
I_{max} (MAX. DISCHARGE CURRENT) <small>Note.4</small>	10kA, 8/20μs
OPERATING TEMPERATURE	-40 ~ +70°C
SAFETY STANDARDS	Compliance to IEC61643-11: 2011, IEC61000-4-5: 2005
DIMENSION	85*37*41 (L*W*H)
PACKING	0.16Kg/Unit ; 10Kg/carton(60pcs)

NOTE: 1. MCOV/U_c: Maximum Continuous Operating Voltage - maximum r.m.s. voltage that could be continuously applied to the SPD.
 2. U_p: IEC 61643-11 Voltage protection level; the highest value of residual voltage measurements during the application of impulses of 8/20μs nominal discharge current(I_n); a rounding voltage value of maximum measurement.
 3. Nominal Discharge Current I_n (A): The nominal discharge current is a measure of the SPDs endurance capability; 15 impulses of discharge current uses the 8/20μs current waveform.
 4. Maximum Discharge Current I_{max} (A): The maximum discharge current is a measure of the SPDs maximum capability; single impulse of discharge current uses the 8/20μs current waveform. All Devices pass maximum discharge current with possible, safe opening of thermal disconnect.

■ Installation Diagram

Series Connection

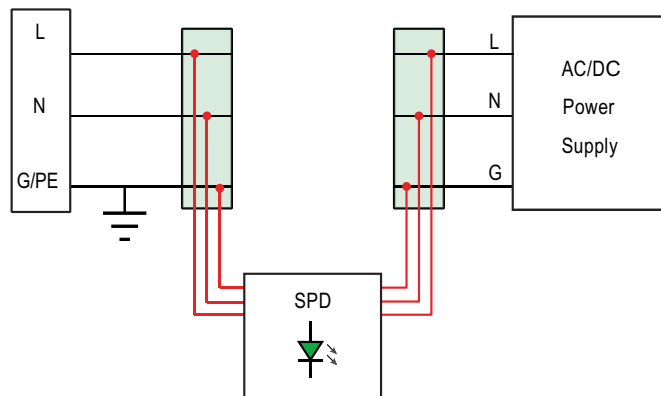

Notes:

1. Green LED light ON: SPD is good
2. Green LED light OFF: SPD needs replacement

■ Mechanical Specification

Unit:mm

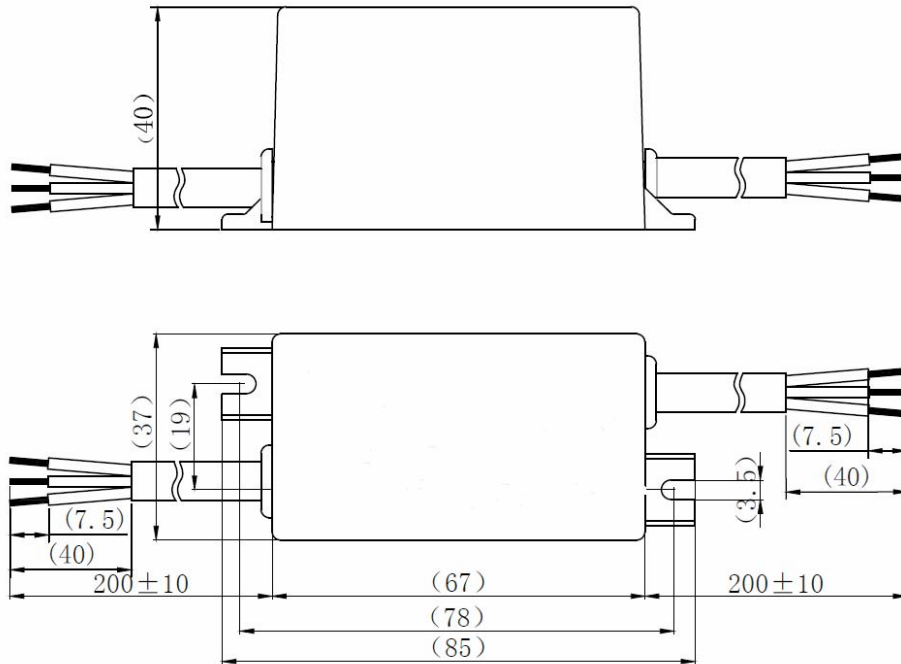
**■ INSTALLATION**

1. This document provides detailed information on how to install and operate the SPD-10-320S. Please refer to "Installation Diagram".
2. The SPD-10-320S of Surge Protective Devices are installed/connected in series with the line of TN System.
3. Before starting any installation procedures, verify service voltage(AC or DC)with a voltmeter to ensure that the correct model has been selected for the supply voltage.
4. DO NOT INSTALL THE SPD IF MEASURED VOLTAGE EXCEEDS UNIT RATINGS.
5. REMOVE POWER FROM ELECTRICAL SYSTEM PRIOR TO INSTALLATION.
6. ENSURE THAT ALL CONNECTIONS ARE CORRECT BEFORE ENERGIZING.
7. Apply power(energize),LED indicator should illuminate. If LED is out, the SPD requires service.