

HRS1(H) Relay

1.COIL DATA

1-1.Nominal Voltage	3 VDC to 24 VDC
1-2.Coil Resistance	Refer to Table 1
1-3.Operate Voltage	Refer to Table 1
1-4.Release Voltage	Refer to Table 1
1-5.Nominal Power Consumption	200 to 360 mW



HRS1(H) Relay

2.CONTACT DATA

2-1.Contact Arrangement	1 Form C
2-2.Contact Material	AuAg
2-3.Contact Rating	1A 24 VDC / 120VAC
2-4.Max. Switching Voltage	30 VDC / 120 VAC
2-5.Max. Switching Current	2A
2-6.Max. Switching Power	120 VA , 24W
2-7.Contact Resistance (Initial)	100 m Ω . at 6 VDC 1A
2-8.Life Expectancy	Electrical 100,000 operations at nominal load Mechanical 10,000,000 operations

3.GENERAL DATA

3-1.Insulation Resistance	Min.100M Ω . at 500 VDC
3-2.Dielectric Strength	1,000VAC , 1min between open contact 1,500VAC , 1min between contacts and coil
3-3.Operate Time	Max. 5ms
3-4.Release Time	Max. 5ms
3-5.Temperature Range	-25 to +55 $^{\circ}$ C
3-6.Shock Resistance	10G
3-7.Vibration Resistance	10 - 55 Hz , Amplitude 1.5mm
3-8.Weight	4 gr.
3-9.Safety Standard	UL/cUL NO. E164730 CSA NO. LR109368-1

4.DIMENSIONS (in mm)



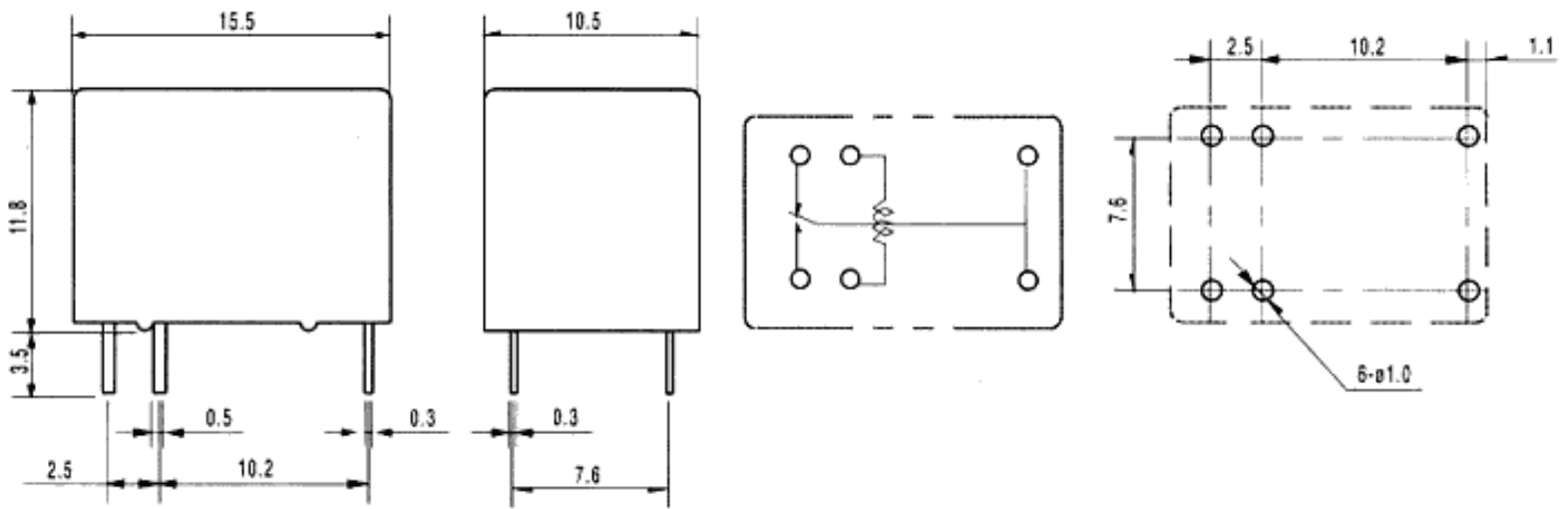

ii

5. ORDERING CODE

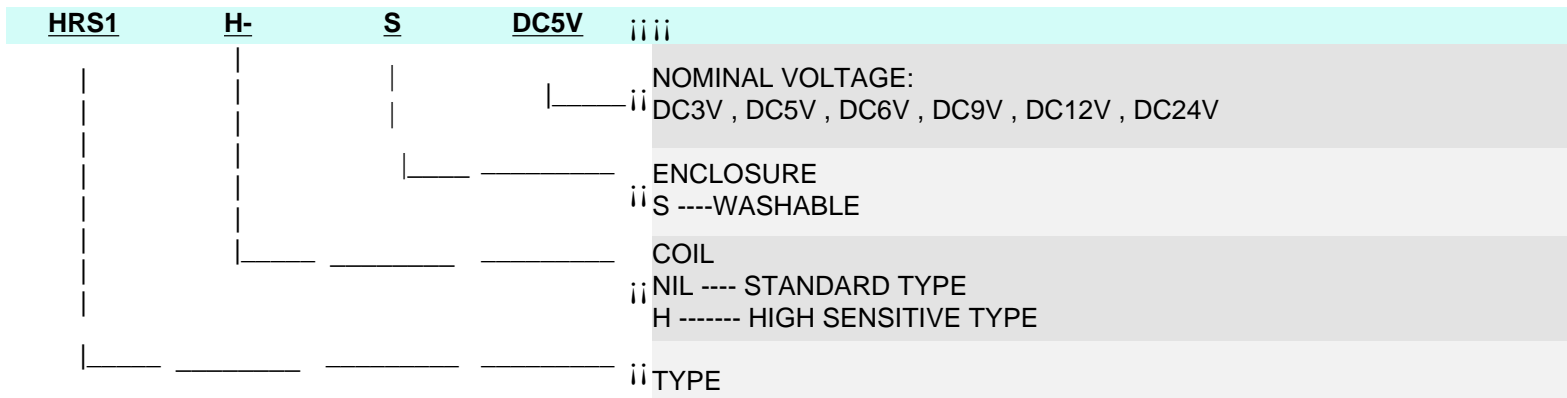

6. COIL DATA CHART

ORDERING CODE	COIL NOMINAL VDC	COIL RESISTANCE Ω, +/- 10%	OPERATE VOLTAGE VDC	RELEASE VOLTAGE VDC	COIL NOMINAL mW
HRS1-S DC3V	3	25	2.25	0.30	360
HRS1-S DC5V	5	70	3.75	0.50	
HRS1-S DC6V	6	100	4.50	0.60	
HRS1-S DC9V	9	220	6.75	0.90	
HRS1-S DC12V	12	400	9.00	1.20	
HRS1-S DC24V	24	1600	18.00	2.40	
HRS1H-S DC3V	3	45	2.25	0.30	200
HRS1H-S DC5V	5	120	3.75	0.50	
HRS1H-S DC6V	6	180	4.50	0.60	
HRS1H-S DC9V	9	400	6.75	0.90	
HRS1H-S DC12V	12	700	9.00	1.20	
HRS1H-S DC24V	24	2800	18.00	2.40	

7.HRS1(H) CHARACTERISTIC DATA

ii

Timing

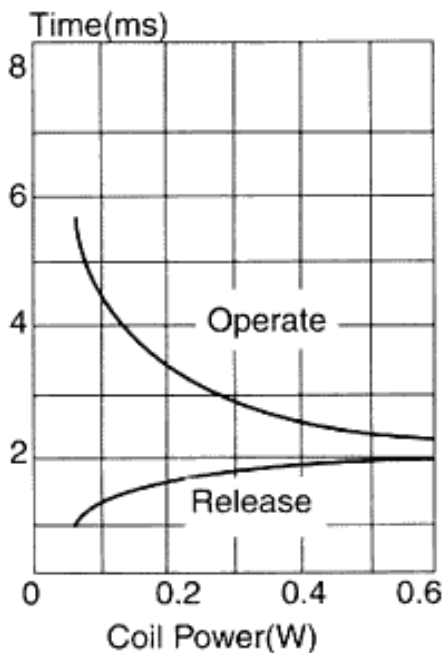

ii

Coil Temperature Rise

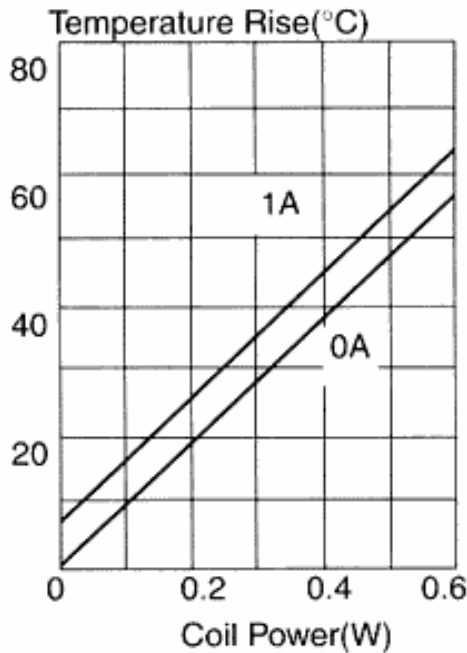

Operating Range

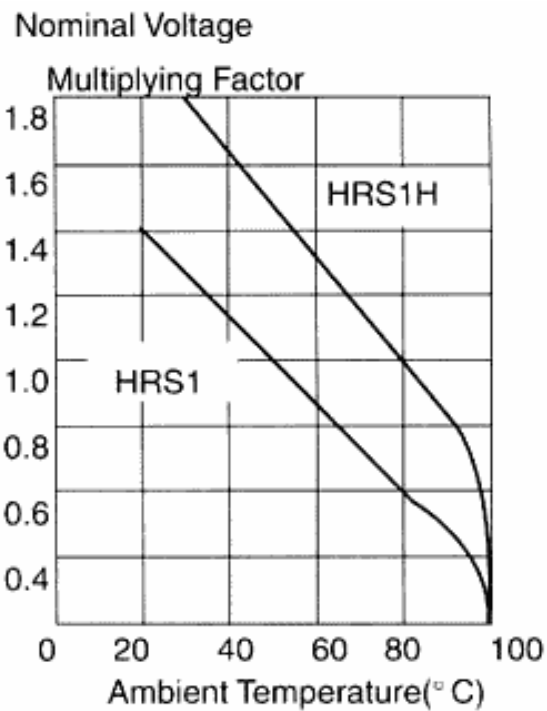

ii

Maximum Switching Power

ii

Life Curve

ii



Contact Current(A)

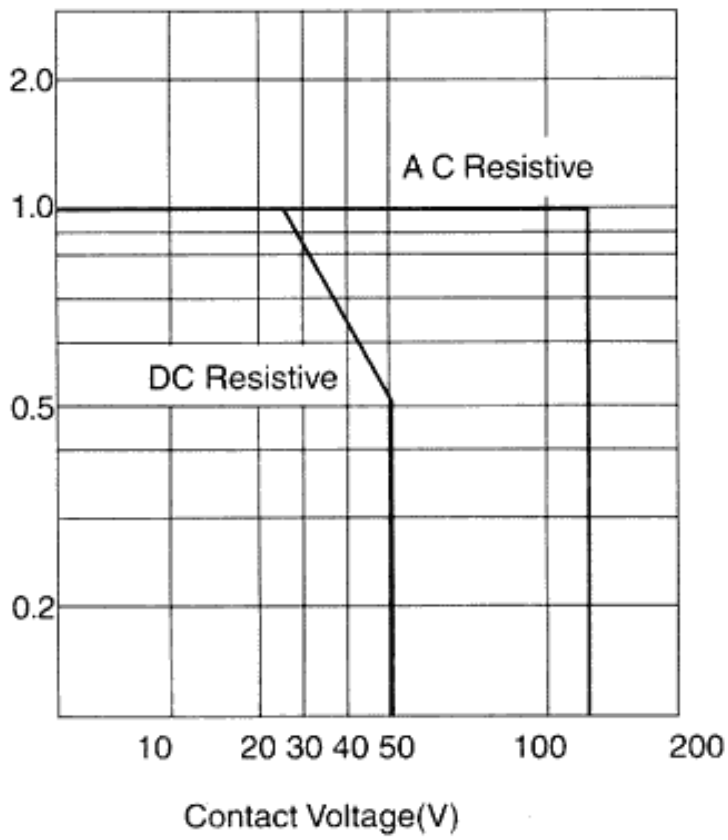

Operation(x10,000)

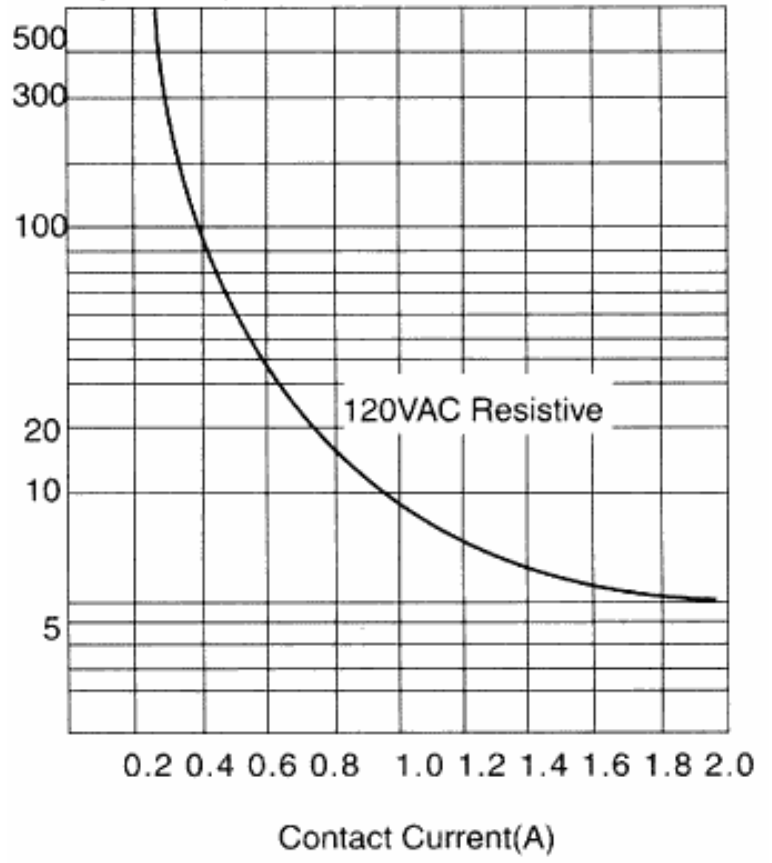

ii

ii

