

深圳市鸿泰电机有限公司

APPROVAL SHEET

客户名称 Customer:

客户料号 Customer P/N:

型号 Model NO.: **DC8025 12V**

料号 P/N:

版本 Version.: **A 0** 样品编号 Sample NO.: **202209-3**

送样日期 Date: **2022-9-26** 样品数量 Quantity: **1PCS**

*如能通过贵公司承认请将承认书签回一份给本公司存档，谢谢！

Please send one copy of this specification back after you signed approval for production pre-arrangement Thanks!

客户承认章 Customer Stamp	
制作：黄迅	
复核：	
核准：	

承认章 Company Stamp	
承认：	
核准：	
日期：	

1.0: 一般规格 (General Specification)

项目 Item		规格/条件 Specification/Condition																	
1	型号 Model No.	DC8025 方框																	
2	外型尺寸 Outline. Dimension	80*80*25mm																	
3	工作电压 Operating Voltage	DC7-3V																	
4	额定电压 Rated .voltage	DC12V																	
5	启动电压 Starting Voltage	≤7V on/off																	
6	额定电流 Rated current	0.04A (Max 0.05A)	a. 额定电压 Rated .voltage b.25°C 65% RH c.After testing for 5 minutes																
7	消耗功率 Power consumption	0.48W (Max :0.6W)																	
8	转速 Speed	2000±10% RPM																	
9	风量 Airflow AT ZERO STATIC PRESSURE	23.6CFM(Min: 23.8CFM)	a. 额定电压 Rated .voltage b. AMCA 标准 Standard C. 额定电流 Rated current																
	静压 Air .Static Pressure AT ZERO AIRFLOW	3.58mmH2O (Min: 3.58mmH2O)																	
10	噪音标准 Noise Level	21dB-A(Max:21dB-A)	a. 额定电压 Rated Voltage b. 18dB无响室 18dB Non-Echo Chamber c. 标准 Standard: CNS 8753 / ISO 3744 d. Test Condition :ISO 7779 e. 距离 Distance: 1.0 M																
11	期望寿命 Life expectancy	40000 hrs at temp40°C Humidity5% ~ 95%	MTTF Mean Time To Failure Conf. Level 90%																
12	扇叶数 No.of.Blade	7 叶																	
13	极数 No.of.Pole	4 极																	
14	运转方向 Rotating Direction	顺时针/运转方向是从标签面看																	
15	锁住保护 Lock Protection	无 NO																	
16	极性保护 Polarity Protection	VCC与GND反接时 不导通 Open circuit when Vcc & GND are exchanged																	
17	过压保护 Over voltage protelt	无 NO																	
18	过流保护 Over current protection	无 NO																	
19	恒速功能 fixed constant speed Function	无 NO																	
20	软启动 Soft Starting	无NO																	
21	PWM 功能 PWM function	无 NO																	
21	PQ 曲线 PQ curve	<p>性能曲线Performance Curve</p> <table border="1"> <caption>性能曲线数据表</caption> <thead> <tr> <th>Flow Rate (CFM)</th> <th>Air Pressure (mmHg)</th> </tr> </thead> <tbody> <tr><td>0</td><td>24</td></tr> <tr><td>4</td><td>21</td></tr> <tr><td>8</td><td>18</td></tr> <tr><td>12</td><td>12</td></tr> <tr><td>16</td><td>8</td></tr> <tr><td>20</td><td>4</td></tr> <tr><td>24</td><td>0</td></tr> </tbody> </table>		Flow Rate (CFM)	Air Pressure (mmHg)	0	24	4	21	8	18	12	12	16	8	20	4	24	0
Flow Rate (CFM)	Air Pressure (mmHg)																		
0	24																		
4	21																		
8	18																		
12	12																		
16	8																		
20	4																		
24	0																		

2.0:主要材料/零件规格 (Main Materials/parts Specification)

材料/零件 Materials/parts		规格 Specification			
1	塑料材料/ 外框扇叶 Plastic Material/ Frame impeller	PBT 黑色风机框叶			
2	轴承 Bearing Type	液压轴承 Hydraulic Bearing			
3	引线 Lead Wire	1007#26 号线框外 260mm			
4	端子 Connector	2.54/2P 端子 1			
		黄	蓝	黑	红
				-	+
5	环保要求 Environmental Requirement	<input type="checkbox"/> ROHS	<input type="checkbox"/> 无卤	<input checked="" type="checkbox"/> 环保标准	<input type="checkbox"/> REACH

3.0 电性规格 (Electrical Specifically)

1	绝缘阻抗 Insulation Resistance	10MΩ/裸线 与外框间测量, 500VDC/min 10MΩ/between unshackled wire and frame at 500VDC/min
2	绝缘耐压 Dielectric Strength	5Ma Max./导线 与外框间测量, 500VAC/min 5Ma Max./Measured between lead wire(+)and frame at 500VAC/min
3	防水等级 Waterproof level	IP XO

4.0 环境测试 (Environmental Specification)

1	运转温/湿度范围 Operating Temp .Range	温度/Temperature:-10°C ~ +70°C 湿度/Humidity:5% ~ 95%RH
2	保存温/湿度范围 Storage Temperature	温度/Temperature:-40°C ~ +75°C 湿度/Humidity:5% ~ 95%RH
3	耐湿性 Humidity	电气规格依据 MIL-STD 202F Method 103B 湿度: 95%RH 温度: 40±2°C
4	热冲击 Thermal Shock	电气规格依据 MIL-STD 202F Method 107D Per MIL-STD 202F Method 107D, Condition D
5	绝缘阶段 Insulation Shock	UL: A 级 UL: Class A
6	包装耐振动试验 Packing Vibration Test	包装后, XYZ 三方向施 3.2G load vibration test for 30min .No serious damage
7	包装耐冲击试验 Packing Shock Proof Test	捆包后, 高 60 公分, 1 棱角 3 边 6 面自然落下, 无严重损坏. 1 corner, 3 edges, 6 faces natural drop from 60cm high packing No serious damage

5.0 在无响室额定电压下之噪音测试

(Noise is measured at rated voltage in anechoic)

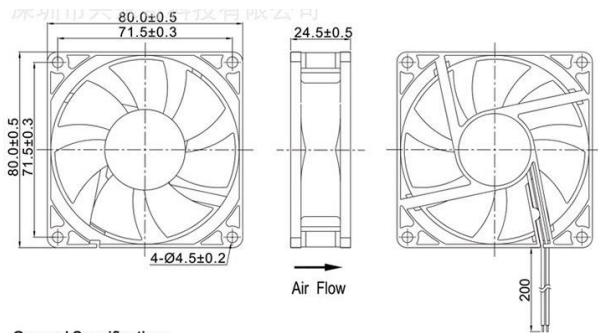
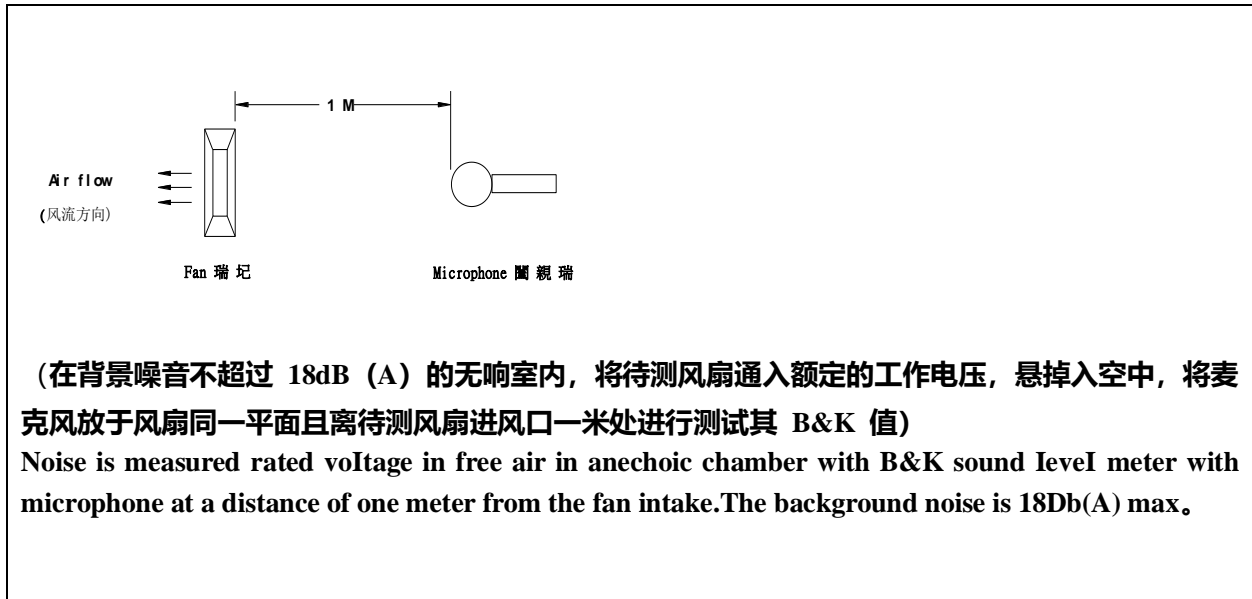

- General Specification:**
- Frame and Impeller: Thermal Plastic, UL 94V-0
 - Lead Wires: UL Type
 - (+): Red (-): Black
 - Operation Temperature: -10°C ~ 70°C、35%~85%RH
 - Storage Temperature: -40°C ~ 70°C、35%~85%RH
- Motor Protection**
- Impedance Protected
 - Reverse Polarity Protected

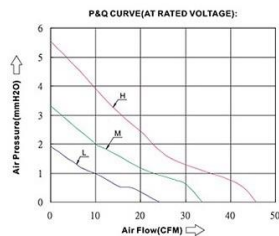

1 Unit:mm



注意事项 (NOTES)

1 Before use, make sure the supply voltage to meet the use of the product range, line-powered load exceeds the maximum power consumption of this product 120%. And the voltage is stable without clutter

(使用前, 确认供电电压能满足本产品的使用范围, 供电电路负载超过本产品的最大功耗的 120%。且电压是稳定不含杂波干扰)

2 Please when ventilator circular telegram normal work do not use the hand to bump touches fan blade border

(请在风扇通电正常运转时不要用手碰触扇叶边沿)

3 Please do not touch the impeller and never carry the fan the lead wires. The bearings and the lead wires may be damaged. Additionally, static electricity may damage the internal circuits of the fan

(请不要碰触扇叶和拉扯线材，以免损坏轴承及导线。此外,静电可能损坏内部的风扇组件)

4 Please do not use the fan in the environment of corrosive gas or liquid.

(请不要将风扇置于腐蚀的气体和液体内)

5 Please do not store the fan in the environment of high humidity. Please avoid storage of the fan over 6 months. For long term storage, please connect power to the fan shortly every 6 months even though the fan is stored in room temperature.

(请不要将风扇储存在高湿度的环境中，请尽量避免将风扇储存期超过 6 个月。如果要长期储存，请将其在室温的环境下。且每隔 6 个月须上电源让风扇短时间运转。)